

9050/9070 **VEHICULAR**



SLIDE GATE OPERATOR



entrapment
prevention system
reverses gate on contact



fail-safe release
Never be locked out (or in)
of your property

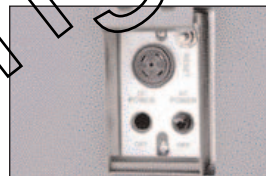

built in
power and reset switches



unique design
allows easy access to all
mechanical parts

- Electronic magnetic limits eliminate old style mechanical switches that can wear out, break or fail
- Automatic self-setting limits mean no limit switch adjustments – ever
- Safety – built-in mechanical and electronic reverse system
- Advanced microprocessor control board features programming switches to set the mode of operation required and has ports for DKS plug-in loop detectors to simplify wiring
- Convenience outlets for accessory transformers
- G90 galvanized steel frame prevents rusting
- This operator meets or exceeds the requirements of the UL 325 and UL 991 safety standards and is ETL Listed
- 5-year limited warranty

FEATURES

ACCESS CONTROL **SOLUTIONS**

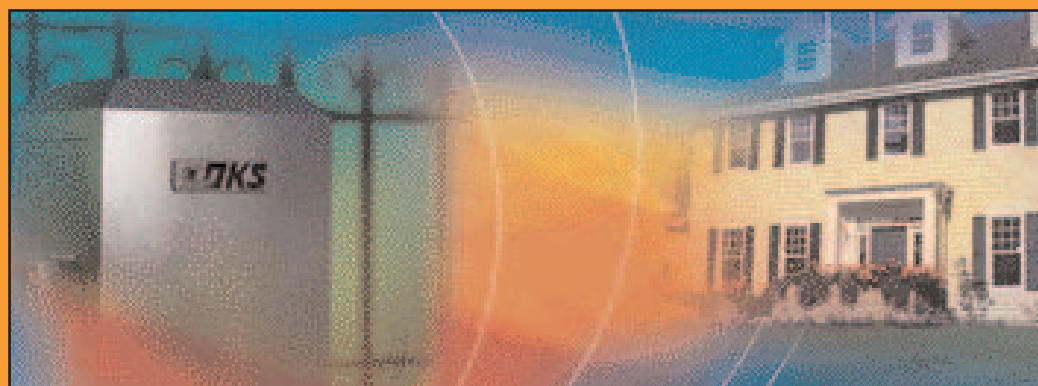



9050/9070 VEHICULAR SLIDE GATE OPERATORS

The DKS 9050 and 9070 slide gate operators offer convenience, reliability and safe operation in a small, compact design. The 9050 operator is ideally used in residential applications while the 9070 can be used in both residential and light commercial applications. The innovative fail-safe design of these operators significantly reduces the chance of injury or entrapment and makes these operators the safest slide gate operators in the market today! Designed with versatility in mind, these operators can be configured for front, center or rear drive applications and can be pad or post mounted.

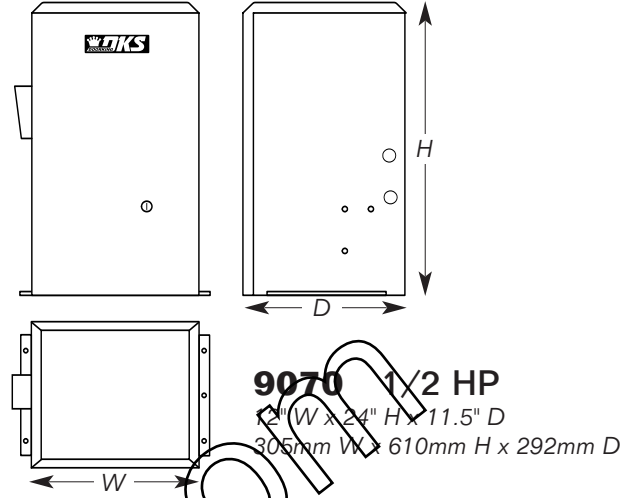
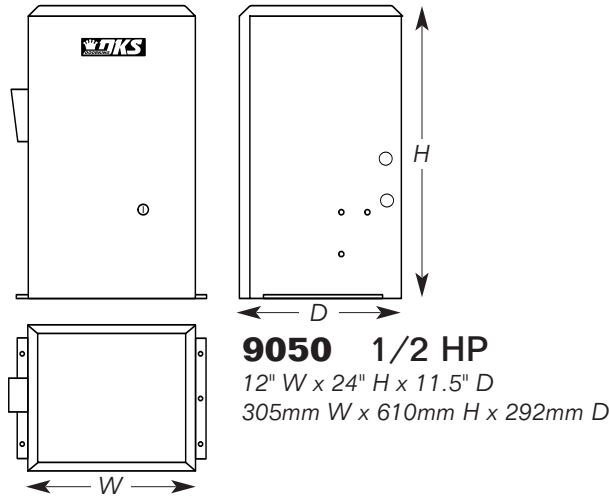

9050 Specs

Class of operation	Max Gate Length *	Max Gate Weight *	HP	Power
I	16 Ft 4.9 m	300 Lbs. 136 kg	1/2HP 10 cycles/hr limited duty	115 VAC, 60 Hz, 4.3A

9070 Specs

Class of operation	Max Gate Length *	Max Gate Weight *	HP	Power
I, II	22 Ft 6.7 m	500 Lbs. 226.8 kg	1/2HP 60 cycles/hr continuous duty	115 VAC, 60 Hz, 5.4A

*Assumes gate to be in good condition on a level surface

General Specs

Mechanical
 Primary Reduction: Single cog belt
 Chain: #41
 Speed: Approximately 10 in/sec (254 mm/sec)
 Cover: Steel cover is plated and painted
 Frame: G90 Galvanized steel to prevent rusting

Manual Release
 Fail Safe: Push gate open
 Fail Secure: Keyed release optional

Operator kit
 includes chain brackets, hardware, and 20-feet (6 m) of #41 chain

Advanced Features
 Automatic limit adjustment
 Auto-close timer 1-23 sec
 Selectable stop / reverse loop function
 Built in On / Off switch
 Built in alarm reset switch
 Two 115 VAC convenience outlets for accessory transformers
 Automatically assumes fail-safe mode when an entrapment condition exists
 Ports for plug-in open and reverse loop detectors. DKS plug-in detectors only

Safety Standards
 Complies with the UL 325 and UL 991 safety standards
 ETL listed

Operating Temp
 10°F to 140°F
 12°C to 62°C
 Heater kit recommended for colder environments

Shipping Weight
 Approximately 70 lbs(31.8 kg)

Warranty
 5-year limited factory warranty

DOOR KING, INC.
 120 Glasgow Avenue, Inglewood, California 90301 U.S.A. Tel: 310-645-0023 FAX: 310-641-1586 www.doorking.com
 © 2005 All Rights Reserved. Product specifications may change without notice. Rev. 3/05

Distributed by: