



# 9100 VEHICULAR SLIDE GATE OPERATOR



**entrapment**  
prevention system  
reverses gate on contact



**fail-safe release**  
Never be locked out (or in)  
of your property



**built in**  
power and reset switches

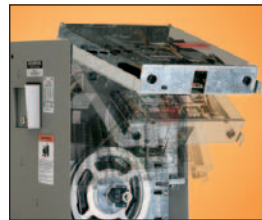

**unique design**  
allows easy access to all  
mechanical parts

- Electronic magnetic limits eliminate old style mechanical switches that can wear out, break or fail
- Automatic self-setting limits mean no limit switch adjustments – ever
- Safety – built-in mechanical and electronic reverse system
- Advanced microprocessor control board features programming switches to set the mode of operation required and has ports for DKS plug-in loop detectors to simplify wiring
- Convenience outlets for accessory transformers
- G90 galvanized steel frame prevents rusting
- This operator meets or exceeds the requirements of the UL 325 and UL 991 safety standards and is ETL Listed
- 5-year limited warranty

FEATURES

ACCESS CONTROL SOLUTIONS





# 9100 VEHICULAR SLIDE GATE OPERATORS

The DKS 9100 operator offers convenience, reliability and safe operation in a small, compact design meant to operate vehicular sliding gates in residential and commercial applications. The innovative fail-safe design of this operator significantly reduces the chance of injury or entrapment and makes it the safest slide gate operator on the market today! Designed with versatility in mind, the operator can be configured for front, center or rear drive applications and can be pad or post mounted.

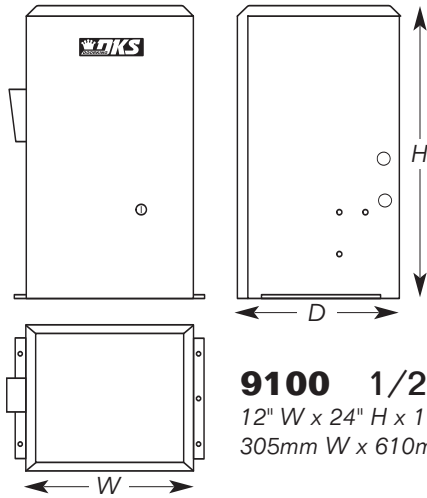

**9100 1/2 HP**  
 12" W x 24" H x 11.5" D  
 305mm W x 610mm H x 292mm D

## 9100 Specs

Class of operation	Max Gate Length *	Max Gate Weight *	HP	Power
I, II, III, IV	30 Ft 9.1 m	1000 Lbs. 453.5 kg	1/2HP continuous duty	115 VAC, 60 Hz, 5.4A

\*Assumes gate to be in good condition and must be on a level surface

## General Specs

### Mechanical

Primary Reduction: Single cog belt  
 Chain: #41  
 Speed: Approximately 10 in/sec (254 mm/sec)  
 Cover: Steel cover is plated and painted  
 Frame: G90 Galvanized steel to prevent rusting

### Manual Release

Fail Safe: Push gate open  
 Fail Secure: Keyed release optional

### Operator kit

includes chain brackets, hardware, and 20-feet (6 m) of #41 chain

### Advanced Features

Automatic limit adjustment  
 Auto-close timer 1-23 sec  
 Selectable stop / reverse loop function  
 Built in On / Off switch  
 Built in alarm reset switch  
 Programming switches allow you to set desired mode of operation  
 Partial-open and anti-tailgating features  
 Two 115 VAC convenience outlets for accessory transformers  
 Automatically assumes fail-safe mode when an entrapment condition exists  
 Ports for plug-in open and reverse loop detectors. DKS plug-in detectors only

### Options Available

#40 chain.  
 Nickel plated chain.  
 Stainless steel chain.  
 Plug-in loop detectors.  
 Heater kit for cold environments.  
 Base plate to post mount (posts not included)  
 Fail-secure keyed release

### Safety Standards

Complies with the UL 325 and UL 991 safety standards  
 ETL listed

### Operating Temp

10°F to 140°F  
 12°C to 62°C  
 Heater kit recommended for colder environments

### Shipping Weight

Approximately 125-185 lbs (65.7-83.9 kg)

### Warranty

5-year limited factory warranty

Distributed by:

**DOORKING, INC.**  
 120 Glasgow Avenue, Inglewood, California 90301 U.S.A. Tel: 310-645-0023 FAX: 310-641-1586 www.doorking.com  
 © 2006 All Rights Reserved. Product specifications may change without notice. Rev. 4/06

### MEMBER:

