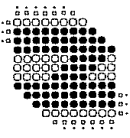

Table of Contents

1. INTRODUCTION	3
2.1 Transmitter.....	5
2.1.1 Functional.....	5
2.1.2 Electrical.....	6
2.1.3 Environmental.....	6
2.1.4 Mechanical.....	6
2.2 Receiver.....	7
2.2.1 Functional.....	7
2.2.2 Electrical.....	8
2.2.3 Environmental.....	8
2.2.4 Mechanical.....	8
3. HARDWARE.....	9
3.1 Transmitter.....	9
3.2 Receiver.....	10
4. PRINCIPLES OF OPERATION.....	11
4.2 Communications Protocols.....	12
4.2.1 34 Bit Wiegand Communication Protocol.....	12
4.2.2 10 Digit Clock&Data Communication Protocol.....	12
4.2.3 TRACK 2000 RS-232 Communication Protocol.....	12
5. CONFIGURATION AND INSTALLATION.....	13
5.1 Transmitter.....	13
5.1.1 General description.....	13
5.1.2 Vehicle Installation.....	13
5.1.3 Recommended Mounting of the Transmitter.....	14
5.2 Receiver.....	16
5.2.1 General Description.....	16
5.2.2 Commissioning procedure.....	16
5.3 Loop and Feeder Installation.....	17
6. CUSTOMER FAULT ANALYSIS	18
APPENDIX A.....	19



1. INTRODUCTION

The TRACK 2000 vehicle identification device allows for the detection and identification of selected vehicles only. The equipment is suitable for a wide variety of applications, for example, the identification of public transport or emergency vehicles, at traffic intersections, for vehicle priority. A block diagram of the TRACK 2000 concept is shown in figure 1. below:

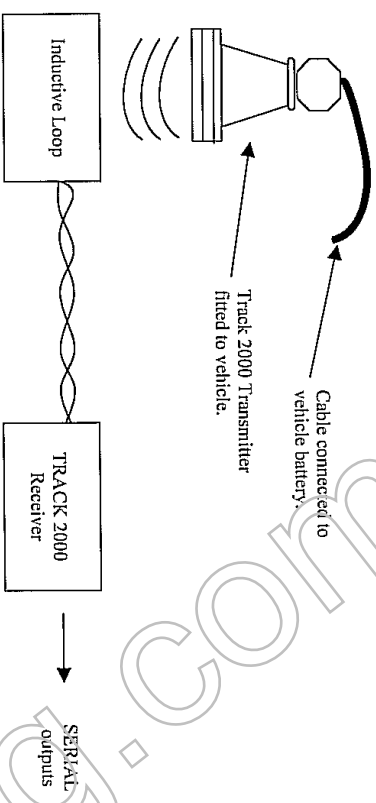

Figure 1.: TRACK 2000 Block diagram

TRACK 2000 consists of TRANSMITTERS which are fixed to the vehicles to be identified, and a RECEIVER which is connected to an inductive loop buried in the road surface.

The TRANSMITTER will transmit a unique code for each vehicle. This unique coding allows for the specific identification of each vehicle fitted with this component. The code, that is to be transmitted, is factory programmed into the transmitter. The TRANSMITTER is powered by the vehicle battery.

The TRACK 2000 RECEIVER is capable of detecting each of the unique TRANSMITTER codes. The RECEIVER is connected to an inductive loop antenna which is buried beneath the road surface. When a vehicle, fitted with the Track 2000 TRANSMITTER, passes over the loop, the RECEIVER will detect the unique code. If the received code is of a valid format it will be serially transmitted to a controller / computer.

The RECEIVER has **RS232, Clock & Data** as well as **Wiegand** outputs for serial transmission of the vehicle's code to a controller:

- RELATED DOCUMENTS**
- 401LFO200 Track 2000 Transmitter Installation Leaflet
 - 401LFO202 Track 2000 Receiver Installation Leaflet
 - 401DS0001 Track 2000 Data Sheet

MODELS COVERED BY THIS MANUAL

- 401FT0200 Track 2000 Transmitter
- 401FT0202 Track 2000 Receiver Wiegand & RS-232

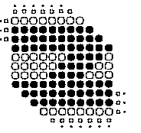

Upswung.com

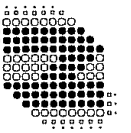

2. TECHNICAL DATA

2.1 Transmitter

2.1.1 Functional

Wiring Protection	No damage will result from reversed or inter-changed leads.
Carrier Frequency	133kHz Long term stability within 1% of initial setting.
Method of modulation	FM.
FM Deviation	± 5 KHz typical
Coupling method To sensing loop	Inductive (transformer action)
Harmonic Content (TYPICAL) Measured ON IFR AN920 Spectrum analyser relative to fundamental	2 nd - (-32dB) 3 rd - (-40dB) 4 th - (-41dB) 5 th - (-44dB) 6 th - (-50dB) 7 th - (-60dB)
No. of output codes	1 unique code per transmitter
Method of coding	Modulation using 32-bit individual code
Stability of tones	Same as RF, oscillator. Tones derived by digital divisions of RF. Oscillator
Method of code selection	none (pre-programmed at factory level)
Reading height	0.1 to 0.8 meters above the loop, dependent on temperature and the speed of the vehicle
Reading Speed	0 to 200 Km per hour

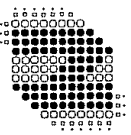

2.1.2 Electrical

Power requirements Suitable for both 12V and 24V vehicles, negative or positive earth.

2.1.3 Environmental

Temperature

Storage Temperature -40°C to +85°C
Operating Temperature -20°C to +70°C
Humidity 0% to 98% non-condensing

2.1.4 Mechanical

Size of Module

Cone Shaped. Base of cone diameter: 85mm
Height of Cone: 87mm

Module Material

Polypropylene. Injection moulded

Colour

Black

Mounting Method

By single bolt mounting at cone apex.
Diameter of mounting hole: 22mm

Mounting Position

Beneath vehicle to a maximum height of 0,8 metre above road surface (to base of cone)
This unit may not be mounted in the engine compartment. The unit must be clear of any metal parts.

Mounting Angle

Base of cone downwards. To be within 30° of horizontal.

Waterproofing

Totally sealed housing. Not affected by water spray.

Vibration and Shock

Designed to withstand the severest mechanical environment on all types of vehicles.

Method of Cable EXT

Through centre of mounting bolt.

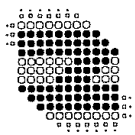

2.2 Receiver

2.2.1 Functional

Front Panel Control	Red LED: Power Yellow (PRESENCE) LED: Transmitter detection Green LED: Valid code format
Operating Instructions	On self-adhesive side label on each unit and installation leaflet
Front Panel Markings	Control switch functions Indicator lamp functions
Rear Panel Markings	Serial number (self adhesive)
Side Panel Markings	Operating instructions, model type, name of Manufacturer
Serviceability	All components readily available.
Receiver Frequency	133kHz
Method of Demodulation	Phase locked loop demodulator
Lightning Protection	Internal. Input transformer coupled and diode clamped.
Adjustable to Various Loops	Automatic (No tuning required)
Loop Tuning Range	10 μ H to 1000 μ H
Loop Feeder Length	Maximum 300 metres
Recommended Feeder Type	A twisted pair insulated multi-strand copper conductor with minimum 0.5 mm ² cross sectional area
Method of Recognition	By the use of a microcontroller for decoding
Output Interface	34 Bit Wiegand (401FT0202) 10 Digit Clock&Data (401FT0203) 10 Digit RS-232 (401FT0202 & 401FT0203)
Output Method	A transmitter over the loop will be indicated by the illumination of the yellow (PRESENCE) LED. A valid code will be indicated by the lighting of the green (CODE) LED. The code is serially transmitted to the controller.

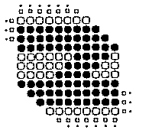

2.2.2 Electrical

Power Requirements

DC voltage of 24V
Tolerance: +10% to -10%
Current rating: 100mA minimum

2.2.3 Environmental

Storage Temperature

-40°C to + 85°C

Operating Temperature

-10°C to +70°C

Relative Humidity

0 to 95 non-condensing
Environmental coating over completed PCB and components

Vibration and Shock

Designed to withstand continuous vibration as experienced in a traffic controller when vibrated by traffic flow

2.2.4 Mechanical

Mounting

Free standing unit. Can be mounted at any angle.

Connector

11-pin-sub-magnal type to industry standard mounted on rear of unit.

Size of Module Housing

Height: 76mm
Width: 39mm
Length: 78mm (excluding connector and controls)

Material of Module Housing

ABS Blend

Colour of Module

Black

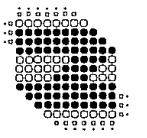

3. HARDWARE

3.1 Transmitter

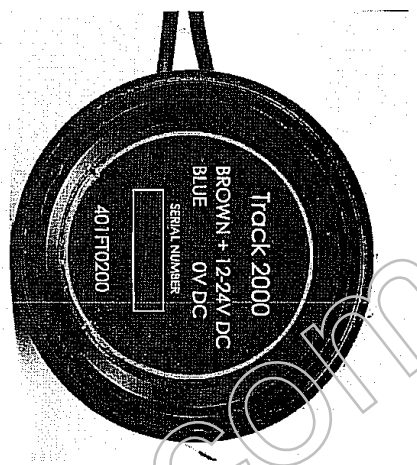

Figure 3.1: TRANSMITTER

TRANSMITTER WIRING DETAIL

COLOUR	FUNCTION
Brown	+12V/+24V
Blue	Ground

3.2 Receiver

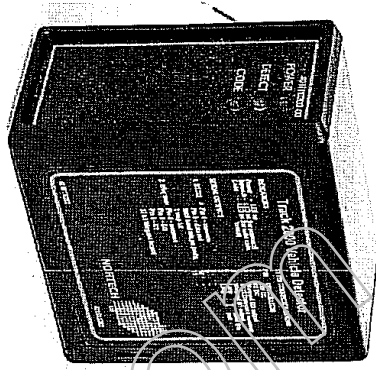
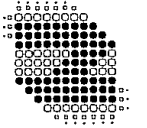
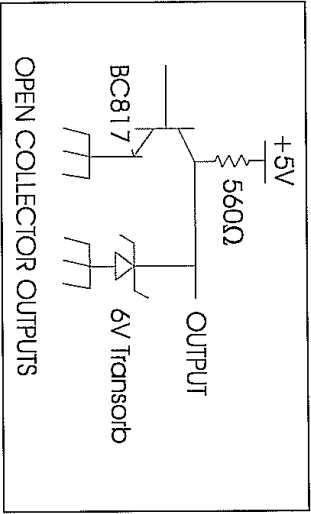
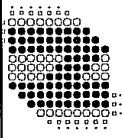

Figure 3.2: RECEIVER

11 PIN SUBMAGNAL CONNECTOR WIRING DETAIL FOR WIEGAND RECEIVER	
PIN	FUNCTION
1	+24V DC input
2	0V DC input
3	Wiegand D0
4	RS232/Wiegand Common
5	Wiegand D1
6	RS232 TX
7	Loop } Twist this
8	Loop } pair
9	Not used
10	Not used
11	Not used

11 PIN SUBMAGNAL CONNECTOR WIRING DETAIL FOR CLOCK & DATA RECEIVER	
PIN	FUNCTION
1	+24V DC input
2	0V DC input
3	Clock output
4	RS232/Clock & Data common
5	Data output
6	RS232 TX
7	Loop } Twist this
8	Loop } pair
9	Card Present
10	Not used
11	Not used





4. PRINCIPLES OF OPERATION

The TRANSMITTER antenna consists of a series resonant LC circuit, tuned to the fundamental carrier frequency as shown in Figure 4.1 (a).

The RECEIVER sensing loop consists of a large coil of wire embedded in the roadway. Therefore, transformer coupling takes place between the RECEIVER and the TRANSMITTER antenna. The TRANSMITTER antenna and RECEIVER loop are shown in figures 4.1.(a) and (b).

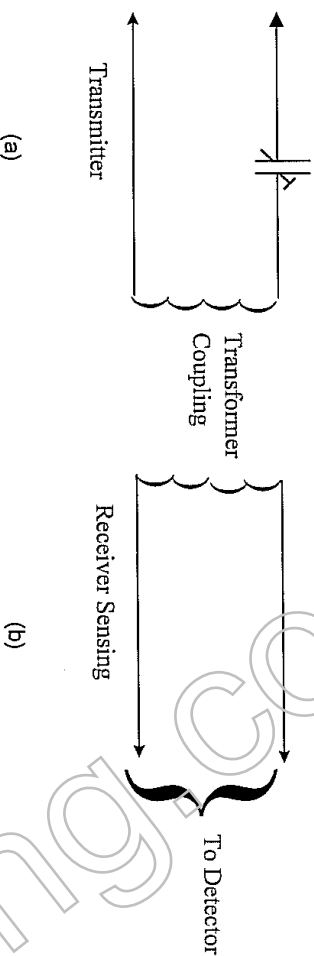

Figure 4.1: Transformer coupling

When a fitted vehicle is present over the sensing loop, the RECEIVER selectively filters out unwanted signals and amplifies the TRANSMITTER carrier signal. When the input signal exceeds a preset threshold, an internal squelch gate opens and permits the received signal to be processed. This squelch threshold is important as it ensures consistent sensitivity from unit to unit.

The codes which are transmitted comprise of the factory pre-programmed codes.

The presence of a vehicle is signalled by the lighting up of the PRESENCE (yellow) LED. If the vehicle's code is of the correct format, the valid code (green) LED lights up and remains on, as long as the vehicle is still present over the loop. The PRESENCE indication LED also remains on during this time. The code of the vehicle is only transmitted once via an RS232, Clock & Data or Wiegand link to the controller.

Output extension timing of approximately 5 second is incorporated to reduce the possibility of multiple output serial transmissions as the TRANSMITTER passes through null areas of the road loop. An LED displays the status of the squelch circuit.

Additional filtering is provided in the circuit to prevent the squelch gate opening with momentary bursts of noise.

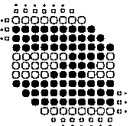

4.2 Communications Protocols

There are three communications options available:

- Wiegand – 34 or 26 Bit
- Clock&Data – 10 or 8 Digit BCD
- RS-232 Autotag-P Point-to-point Protocol

There are two models of TRACK 2000 Receivers, either the 401FT0202 model or the 401FT0203 model. The difference between the two is the communications models.

The 401FT0202 model has the “34 Bit Wiegand” and “RS-232” Communications Protocols, where the 401FT0203 has the “Clock&Data” and “RS-232” Communication Protocols.

4.2.1 34 Bit Wiegand Communication Protocol

This is an uni-directional Protocol (from the TRACK 2000 Receiver to the Access Controller).

For 34 Bit Wiegand, the 32 Bit unique code from the TRACK 2000 Transmitter has two parity bits added and is then sent out on the WIEGAND lines.

4.2.2 10 Digit Clock&Data Communication Protocol

This Protocol is also known as “Magnetic Stripe Track 2”.

This is an uni-directional Protocol (From TRACK 2000 Receiver to the Access Controller)

The 32 Bit unique code from the Track 2000 Transmitter is converted to 10 digit BCD. Each BCD digit gets it's own parity bit. The resultant digits together with a message header and footer are used to calculate the message check digit and then sent out on the CLOCK&DATA lines.

4.2.3 TRACK 2000 RS-232 Communication Protocol

This is a uni-directional Protocol (from the TRACK 2000 Receiver to the Access Controller).

The 32 Bit unique code from the TRACK 2000 Transmitter is converted to 10 digit BCD and then to ASCII. This 10 digit ASCII string is sent out on the RS-232 transmit line.

Data Format: 8 data bits
No parity
One stop bit
Baudrate 9600

NOTE: There is NO end of message terminator added to this 10 ASCII digit string. The delay between each digit of the string is very short. The User's Access controller must be capable of differentiating between the two strings from vehicles travelling one behind the other at high speeds.

The total length of the RS-232 communications wires is limited to 10 meters (30 feet).

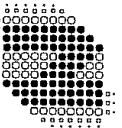

5. CONFIGURATION AND INSTALLATION

5.1 Transmitter

5.1.1 General description

The TRANSMITTER is a highly robust module intended for mounting beneath a vehicle. The unit is cone shaped to facilitate easy mounting. The cone is hermetically sealed to ensure weatherproofing. The seal prevents any tampering with the circuit electronics and is not repairable. (The TRANSMITTER has a two-year warranty.) A single mounting bracket is recommended, with the power cable passing through the centre shaft of the transmitter's housing.

The unit is designed to operate from the vehicle battery. A DC voltage in the range 11 to 40 volts is required. The consumption of current depends on supply voltage but ranges typically from 20 to 50mA.

No regulation of the supply voltage is necessary as an internal regulator removes any ripple or noise from the source. The design ensures that no damage can occur to the circuit's irrespective of how the power cables are terminated to the power source.

5.1.2 Vehicle Installation

1. Choose a position for the TRANSMITTER which is approximately midway, breadth-wise, across the vehicle. Position as close as possible to the front of long vehicles (buses, trains and trucks). This will ensure the vehicle is detected when stopping at loops situated at intersections. Refer to Figure 5.1 for suggested mounting areas of the TRANSMITTER.

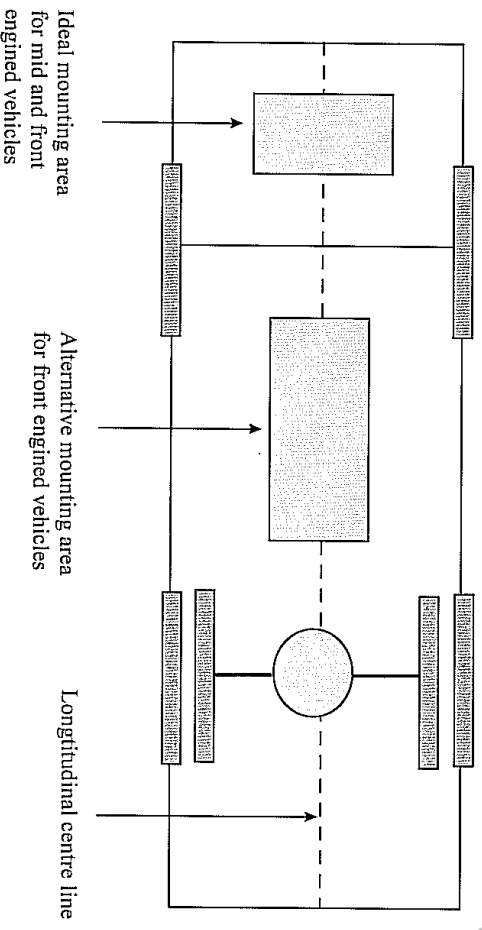
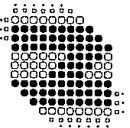

Figure 5.1: Underside view of vehicle



2. Endeavour to keep the TRANSMITTER mounting position along the centreline of the vehicle. This optimises the TRANSMITTER positioning with respect to the sensing loop. However, on electrically driven vehicles (trams etc.) the TRANSMITTER must be positioned as far as possible from the traction motor and control circuitry. That is, at the front or the rear of the vehicle.
3. Mount the TRANSMITTER (cone) so that the base of the cone is horizontal to the surface of the road. Deviations of up to 30° from the horizontal are permissible.
4. Mount the TRANSMITTER so that the base is within 0.8 metres of the road surface. Choose a protected place so that stones and similar objects displaced by the wheels cannot cause any damage.
5. It is important that the unit is directly visible from beneath, and that it is not positioned behind chassis members. Furthermore, a minimum clear area of 100mm is required around the periphery of the cone base.
6. Avoid all areas beneath the vehicle, which are subject to fuel and oil leaks, and accumulations.

5.1.3 Recommended Mounting of the Transmitter

1. Insert a bracket onto the transmitter, by first removing the nut and washer on the unit. Pull the power cable out of the bracket and insert the bracket in order for the transmitter to be higher than the point where the bracket is mounted.
2. Using an open-ended spanner, carefully tighten the bolt on the transmitter.
3. Drill holes on the chassis for mounting the bracket. Route the power cable along the vehicle's chassis.
4. Ensure that the bracket together with the transmitter are now secured in place.
5. Route the TRANSMITTER cable to a convenient point where it can be connected to the vehicle's power source. Ensure that the correct lead is securely earthed to the vehicle bodywork. (Remove all paint from the area and use a serrated washer in conjunction with the lug securing screw.) Refer to Figure 5.2 for TRANSMITTER mounting details. Correct wiring for both negative and positive earthed vehicles is shown in Figures 5.3 and 5.4.
6. When routing the cable avoid any sharp points on the chassis or bodywork which may cause chaffing. At every point that the cable passes through the bodywork of the vehicle, ensure that a rubber grommet is used.
7. Use cable ties to secure the cable at strategic points to prevent movement and fatigue.
8. Solder all connections and extensions to the power/control cable and insulate/waterproof to standard of existing cable.
9. Liberally spray the mounting nuts and bolts and all earthing point hardware with a quality chassis type sealer / corrosion inhibitor. (Example Valvoline "Teely").
10. Test the unit by driving over a loop which has a receiver attached.

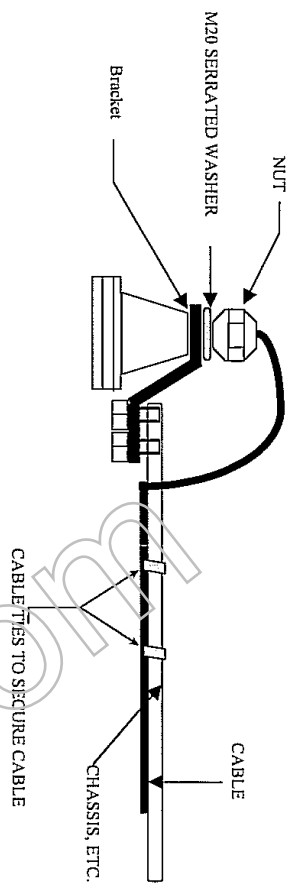
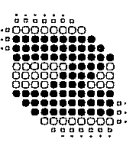
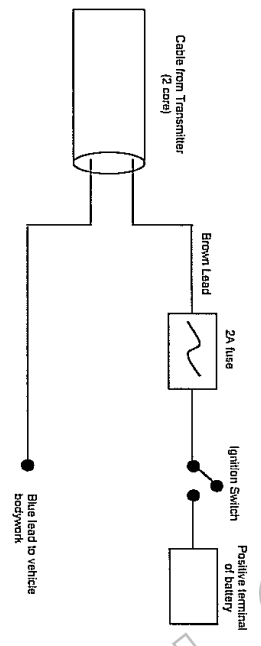

Figure 5.2: Recommended TRANSMITTER mounting details



NB: All connections to be soldered

Figure 5.3: TRANSMITTER wiring (negative earth vehicles)



NB: All connections to be soldered

Figure 5.4: TRANSMITTER wiring (positive earth vehicles)

WARNING: Do not connect the transmitter directly to the vehicle's battery, but rather via the ignition switch.

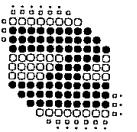

5.2 Receiver

5.2.1 General Description

The TRACK 2000 RECEIVER is packaged in an ABS plastic housing. This unit is the same size as the industry standard for inductive loop vehicle detectors and has the same connector. It may therefore be accommodated on the detector shelf of traffic control equipment or as a "stand alone" module in other control equipment. The glass-epoxy printed circuit board and components are coated with an environmental coating, which prevents moisture ingress.

Special circuits are employed to reject unwanted electrical interference, and frequency modulation of the transmitter is used in conjunction with phase locked loop detectors techniques to further enhance performance under difficult conditions.

Virtually any existing loop and feeder configuration within the inductance range of 10 to 1000 microhenries can be used. No on-site tuning adjustments are required.

A flickering PRESENCE (yellow) LED, with no TRANSMITTER over the loop indicates the presence of electrical interference.

The three front panel LEDs display the status of the RECEIVER. Lightning protection is built into the equipment. The loop input is isolated from the rest of the circuitry by an isolation transformer.

A 24V external DC power supply is needed which can source at least 100mA. The unit is supplied with an 11-pin rear mounted sub-magnal connector.

5.2.2 Commissioning procedure

STEP 1: Power up the RECEIVER and all other equipment, particularly loop detectors, in the vicinity. (In order to eliminate interference.)

STEP 2: Observe that the PRESENCE (yellow) LED does not glow. A continuously glowing PRESENCE (yellow) LED indicates crosstalk from a loop detector or other source. Remedy this by isolating the particular loop detector(s) and varying their operating frequency. All modern loop detector modules have this adjustment facility.

This interference must be monitored with vehicles traversing the loops, as many loop detectors feature a free running front end oscillator, the frequency of which is varied by vehicles traversing the sensing loop. Ensure that all the vehicles fitted with the Track 2000 TRANSMITTER are detected.

STEP 3: A flickering PRESENCE (yellow) LED normally indicates interference from the mains supply. NOTE: Random flashes of the PRESENCE (yellow) LED are not important. Special circuits within the RECEIVER cancel out electrical noise effects.

STEP 4: The unit is now operational and the three front panel LEDs show the output status.

NOTE: It is normal for the PRESENCE (yellow) LED to glow whenever a TRANSMITTER is over the loop.

5.3 Loop and Feeder Installation

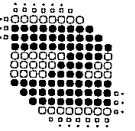

All permanent loop installations should be installed in the roadway by cutting slots with a masonry cutting disc or similar device. A 45° crosscut should be made across the loop corners to reduce the chance of damage that can be caused to the loop at right angle corners.

NOMINAL SLOT WIDTH: 4mm

NOMINAL SLOT DEPTH: 30 mm to 50 mm

A slot must also be cut from the loop circumference at one corner of the loop to the roadway edge to accommodate the feeder. A continuous loop and feeder is obtained by leaving a tail long enough to reach the receiver before inserting the cable into the loop slot. Once the required number of turns of wire are wound into the slot around the loop circumference, the wire is routed again via the feeder slot to the road edge. A similar length is allowed to reach the receiver and these two free ends are twisted together to ensure they remain in close proximity to one another. (Minimum 20 turns per metre) Maximum recommended feeder length is 300 metres. The loops are sealed using a "quick-set" black epoxy compound or hot bitumen mastic to blend with the roadway surface.

FURTHER DETAILS ON LOOP INSTALLATION IS AVAILABLE IN OUR USER MANUAL "INDUCTIVE VEHICLE LOOP DETECTION" Reference MKT01.

For the installation of the Track 2000 RECEIVER, the gauge of wire has little effect on overall performance. However, it is recommended that heavy duty insulation wire with a rating of 16 amps and over is used for the loop and feeder. Note that the heavier the wire gauge, the greater the robustness of the loop, particularly in areas that experience large summer / winter temperature variations and road freezing.

Polyethylene is the preferred insulation material for the loop wire as PVC type insulation is both water porous and soft.

A loop width of 1 metre in the direction of traffic flow is recommended, however existing loop installations which may be considerably wider, are generally acceptable. The unit is highly tolerant to loop size variations and will operate with virtually any loop falling within the 10 - 1000 microhenry inductance range.

Loops that are to be used in conjunction with the TRACK 2000 RECEIVER should be positioned so as to be at least 3 metres away from the adjacent parallel edges of other inductive loops connected to vehicle detectors. Restrict loop length to 3 metres maximum. Ensure that the minimum length is equal to the width of the TRANSMITTER equipped vehicle. Loops of total circumference less than 6 metres should comprise 3 turns, all other loops 2 turns. Two smaller loops may be connected in parallel for wide entrances. Ideal Loop: 1.8m x 1.8m. For minimum noise pick-up ensure that the feeder is preferably of a twin core screened type although in most applications unscreened twin core feeder is adequate. There is no minimum feeder length specified.

Note that all loop and feeder joints are to be soldered and insulated to meet original cable specification.

Finally, check the earth leakage DC resistance of the loop to equipment ground. At completion of a new installation this should exceed 20 Megohms, and on other existing loops should exceed 10 Megohms. Conduct this measurement with a megger type high voltage tester.

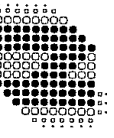

6. CUSTOMER FAULT ANALYSIS

FAULT		CAUSED BY	REMEDY
Power LED on the receiver does not light up when unit is powered up. Presence LED and Code LED do not light up when a Track 2000 transmitter is over the loop.	a)	Incorrect application of the supply voltage to the unit.	a) Check the power feed to the unit.
	a)	The transmitter unit has not been powered up correctly.	a) Check the power feed to the transmitter unit.
Code LED does not light up even though the Presence Led lights up.	b)	The loop isn't properly connected to the receiver.	b) Ensure that the loop is not open-circuited, and verify it's connection to the receiver unit.
	c)	Transmitter is mounted too high above the loop	c) Ensure that the transmitter is within the specified maximum height above the loop.
	d)	Metal in the vicinity of the loop.	d) Follow proper installation instructions for the loop and ensure that there are no metal obstructions within the immediate vicinity of the loop.
	e)	Unwanted sources of transmissions.	e) Ensure that there are no other transmitters or equipment in the vicinity of the loop which radiate transmissions in the lower radio frequency bands (i.e.: <1MHz).
No RS232 reception at the controller / computer	a)	Unknown transmitter is over the loop.	a) Ensure that the valid transmitter unit is over the loop.
	b)	Unwanted sources of transmission.	b) Ensure that there are no other transmitters or equipment in the vicinity of the loop which radiate transmissions in the lower radio frequency band (i.e.: <1MHz).
	c)	Insufficient voltage to the receiver.	c) Ensure that the supply voltage to the receiver lies within the specified range.
No Wiegand / Clock & Data reception at the controller / computer.	a)	Incorrect connection of the RS232 output lines from the receiver to the controller / computer.	a) Ensure that the connections for RS232 output from the receiver are correctly interfaced to the controller / computer.
	b)	Incorrect RS232 format expected by the controller / computer.	b) Ensure that the controller / computer has been set up to accept the correct format of RS232 output from the receiver in terms of baud rate, parity and stop bits.
No Wiegand / Clock & Data reception at the controller / computer.	a)	Incorrect connection of the Wiegand / Clock & Data output line from the receiver to the controller / computer.	a) Ensure that the connection for Wiegand / Clock & Data output from the receiver are correctly interfaced to the controller / computer.
	b)	Incorrect Wiegand / Clock & Data format expected by the controller / computer.	b) Ensure that the controller / computer has been set up to accept the correct format of Wiegand / Clock & Data output from the receiver.

APPENDIX A

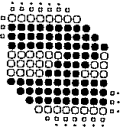

TRACK 2000 "W" REG AND "R" CONNECTION DIAGRAM

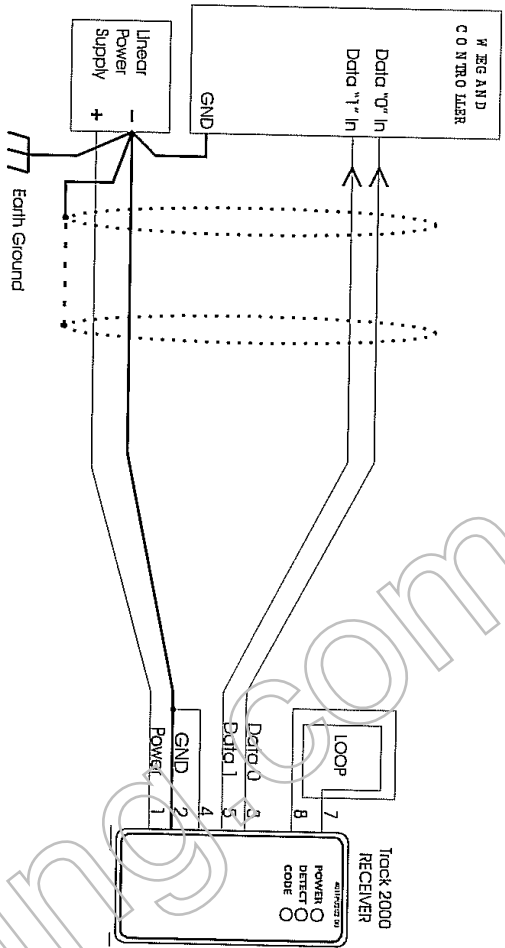

TRACK 2000 "R" RS232 "C" CONNECTION DIAGRAM

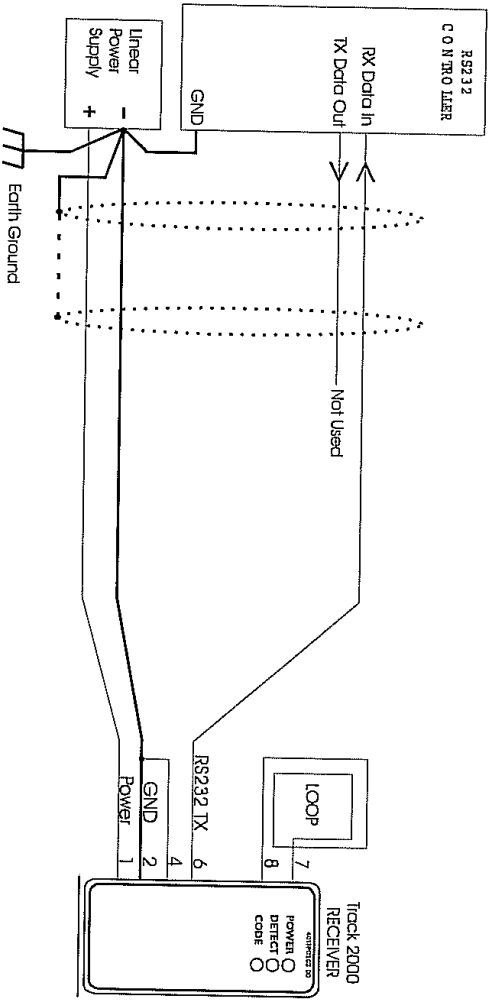

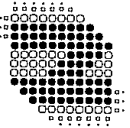

TRACK 2000 "Clock & Data" CONNECTION DIAGRAM

