

## CONTROL UNIT 596/615 BPR

### 1. WARNINGS

**⚠** Before attempting any work on the electronic equipment (connections, maintenance), always turn off power.

- Install, upstream of the system, a differential thermal breaker with adequate tripping threshold.
- Always separate power cables from control and safety cables (push-button, receiver, photocells, etc.). To avoid any electrical disturbance, use separate sheaths or a screened cable (with the screen earthed).

### 2. TECHNICAL SPECIFICATIONS

Power supply voltage	230V ~ - 50Hz
Absorbed power	4 W
Motor max. load	800 VA
Accessories max. current	250 mA
Environment temperature	-20°C to +55°C
Fuses	F1 = 6.3A-250V F2 = self-resetting
Operating logics	B/C, B, C, EP, AP, P, A default = EP
Work time (time-out)	Self-learning (0-10 min in 2.5 sec steps) Default = 10 min
Pause time	Self-learning (0-5 min in 1.5 sec steps) Default = 15 sec
Terminal board inputs	Open, Close, Stop, Limit-switch, CL safety devices, Power supply
Terminal board outputs	Motor, flashlight, courtesy light and power supply to accessories
Programmable functions	Operation for barrier or up-and-over Logic
Functions through learning	Work time, Pause time

### 3. LAYOUT AND COMPONENTS

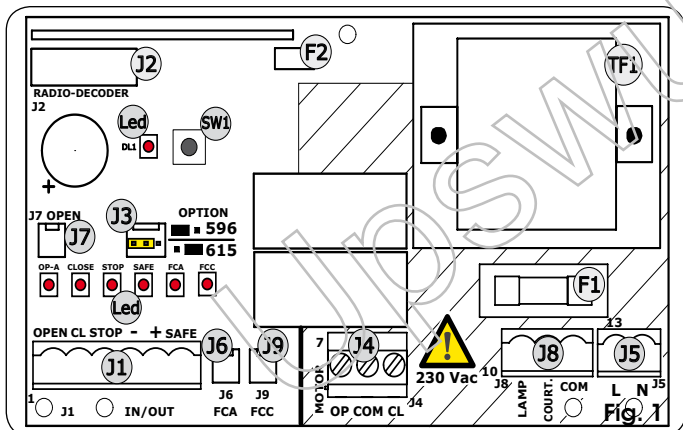

#### Description of components

J1	inputs terminal board and power supply to accessories
J2	connector for radio receiver (see Note)
J3	select operation: 596 or 615
J4	motor terminal board
J5	230 Vac power supply terminal board
J6	opening limit-switch connector (N.C. contact)
J7	OPEN command connector (for up-and-over)
J8	terminal-board for flashlight and courtesy light
J9	closing limit-switch connector (N.C. contact)
LED	Signalling LEDs
SW1	programming key
TF1	transformer
F1	6.3A- 250 V (motor protection)
F2	self-resetting (accessories protection)

**⚠** An RP2 type 2-channel receiver can be connected to the J2 connector, so that the OPEN and CLOSE facilities of the automated system can be commanded directly with a 2-channel radio control.  
If using a single-channel RP type receiver, only OPEN can be commanded.

### 4. CONNECTIONS

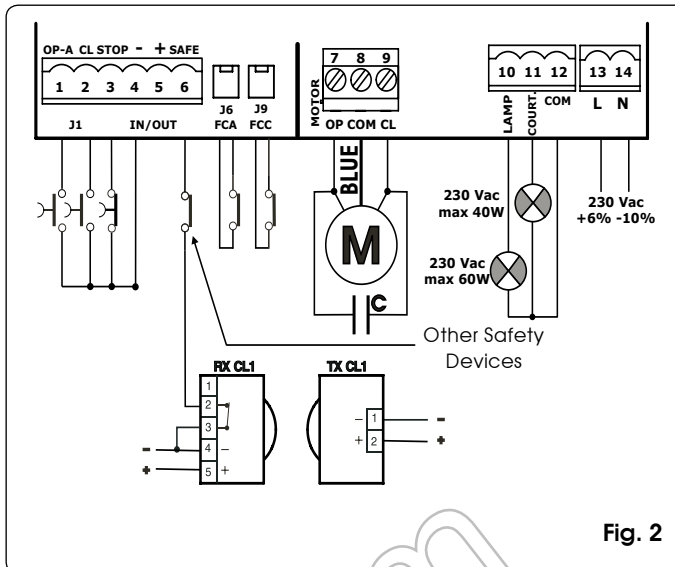

Fig. 2

#### Description of terminal boards

Terminal	Description	Device connected
1	OPEN	Device with N.O. contact (see chap. FUNCTION LOGICS)
2	CLOSE	Device with N.O. contact (see chap. FUNCTION LOGICS)
3	STOP	Device with N.C. contact which causes the automated system to lock
4	- 24Vdc	Power supply for accessories
5	+ 24Vdc	
6	SAFE	Closure safety device with N.C. contact (see chap. FUNCTION LOGICS)
7	OP	Motor opening stage
8	COM	Motor common contact
9	CL	Motor closure stage
10	LAMP	Output for flashing light 230 Vac max 60W
11	COURT.	Output for courtesy light 230 Vac max 40W timing 90 sec. not modifiable
12	COM	Common contact for light/flashing light
13 - 14	L - N	Board power supply (230Vac)

**⚠** On boards supplied as a spare part or with operators on which the limit-switches are optional items, the contacts of connectors J6 and J9 are short circuited. If sensors are being installed, eliminate the jumpers and connect the limit-switches directly or via the specific adaptor, to the connectors. When the travel-limit sensor is engaged, operation varies according to operation setting as 596 or 615 (J3).

#### 596

**Opening:** immediate stop when sensor is engaged.

**Closing:** when the sensor is engaged, the operator works for 4 sec in slow-down and for 1 sec. at standard speed (over-pushing stroke).

#### 615

**Opening and closing:** when the sensor is engaged, slow-down is executed with a duration of half the time at standard speed.

**If the travel-limit sensors are not installed, the appliance executes only the learnt work time (see par.6.2).**

### 5. PROGRAMMING THE FUNCTION LOGIC

To select the function logic, press the SW1 push-button the number of times equal to the number of the required logic, irrespective of the current logic and the door status. The interval between the pulses must be less than 1 second.

The selected logic is then continuously displayed by the DL1 LED, which flashes once a second at 3 sec intervals, equal to the number of the required logic.

To select the logics, press SW1 the number of times indicated in the table below:

No.	Logic	Description	SW1 PRESSINGS
1	B/C	Mixed B / C	once
2	B	Semiautomatic B	twice
3	C	Manned	3 times
4	EP (default)	Stepped semiautomatic	4 times
5	AP	Stepped automatic	5 times
6	P	Stepped automatic	6 times
7	A	Automatic	7 times

### 6. START-UP

#### 6.1. LEDS CHECK

The following table shows the status of the LEDs in relation to the status of the inputs (the closed at rest automated system condition is shown in bold). If the travel-limit sensor inputs are connected to terminal 7 (-), the FCA and FCC LEDs are always lighted. Check the status of the signalling LEDs as per table below:

#### Operation of status signalling LEDs

LED	ON (closed contact)	OFF (Open contact)
DL1	Flashing to indicate selected logic	
OP-A	Command enabled	<b>Command disabled</b>
CLOSE	Command enabled	<b>Command disabled</b>
SAFE	<b>Safety devices disabled</b>	Safety devices engaged
STOP	<b>Command disabled</b>	Command enabled
FCA	<b>Opening limit switch free</b>	Opening limit switch engaged
FCC	Closure limit switch free	<b>Closing limit switch engaged</b>

#### 6.2 TIME LEARNING

Time learning instructions:

1. Release the automated system and put it into closed position. Check if the closing travel-limit sensor (if present) is engaged (FCC LED OFF) and if the STOP and SAFE LEDs are lighted;
2. press SW1 and hold it down until the automated system begins the opening operation;
3. Operation without travel-limit sensor: when the automated system has reached opening position, wait 2-3 seconds and then press SW1 again or command OPEN to stop the operator;  
Operation with travel-limit sensor: the automated system will stop automatically when the opening limit-switch is reached. After the motor stops, the board begins to learn the extra work time (time-out after which the board commands the motor to stop if the stop limit-switch is not reached correctly). Wait for the time you require (max= 10 min), and then press OPEN or SW1 to save it;
4. if the A or AP logic is set, after completing the procedure at point 3, the board starts to learn the pause time. Wait for the pause time you require, and then press OPEN or SW1 again to save it (max = 5 min) and the automated system will automatically begin to close the door;
5. if, instead, a logic other than A or AP is set, the learning stops at point 3. To close the door, press OPEN or CLOSE, according to the logic.

### 6.3 PRE-FLASHING

If you wish to increase the equipment's safety level, you can activate the pre-flashing function which enables the flashing lamp to go on 3 seconds before the starts move.

Pre-flashing activation procedure:

- 1) check if the gate is closed
- 2) open and keep open the **Stop** contact
- 3) check if the **DL1** LED is OFF (if lighted, pre-flashing is already active)
- 4) briefly press the **SW1** push-button and check if the **DL1** LED lights up.
- 5) close the **Stop** contact (DL1 goes OFF).

Procedure for disabling the function:

- 1) check if the gate is closed
- 2) open and keep open the **Stop** contact
- 3) check if the **DL1** LED is lighted (if OFF, pre-flashing is already disabled)
- 5) briefly press the **F** push-button and check if the **DL1** LED is OFF.
- 6) close the **Stop** contact

### 7. AUTOMATED SYSTEM TEST

When you have finished programming, check if the system is operating correctly. In particular, check if the safety devices are operating correctly.

**8. FUNCTION LOGICS**

**LOGIC B/C**

Status	Open (pulse)	Close (maintained)	Stop	Safe
Closed	Opens	/	Disables Open and Close	/
Opening	/	Closes	Locks	/
Open	/	Closes	Disables Open and Close	Disables closing
Closing	Opens	Closes	Locks	Opens
Locked	Opens	Closes	Disables Open and Close	Disables closing

**LOGIC B**

Status	Open (pulse)	Close (pulse)	Stop	Safe
Closed	Opens	/	Disables Open and Close	/
Opening	/	Closes	Locks	/
Open	/	Closes	Disables Open and Close	Disables closing
Closing	Opens	/	Locks	Opens
Locked	Opens	Closes	Disables Open and Close	Disables closing

**LOGIC C**

Status	Open (held)	Close (held)	Stop	Safe
Closed	Opens	/	Disables Open and Close	/
Opening	Opens	Locks	Locks	/
Open	/	Closes	Disables Open and Close	Disables closing
Closing	Opens	Closes	Locks	Locks
Locked	Opens	Closes	Disables Open and Close	Disables closing

**LOGIC EP**

Status	Open (pulse)	Close (pulse)	Stop	Safe
Closed	Opens	/	Disables Open and Close	/
Opening	Locks	Closes	Locks	/
Open	Closes	Closes	Disables Open and Close	Disables closing
Closing	Locks	/	Locks	Opens
Locked	Starts in opposite direction (always closes after a Stop)	Closes	Disables Open and Close	Disables closing

**LOGIC AP**

Status	Open (pulse)	Close (pulse)	Stop	Safe
Closed	Opens and closes after pause time	/	Disables Open and Close	/
Opening	Locks	Closes	Locks	/
Pause	Locks	Closes	Locks	Repeats pause
Closing	Opens	/	Locks	Opens
Locked	Closes	Closes	Disables Open and Close	Disables closing

**LOGIC P**

Status	Open (pulse)	Close (pulse)	Stop	Safe
Closed	Opens	/	Disables Open and Close	/
Opening	/	Completes opening and then closes	Locks	/
Open	/	Closes	Disables Open and Close	Disables closing
Closing	Opens	/	Locks	Locks and closes on release
Locked	Opens	Closes	Disables Open and Close	Disables closing

**LOGIC A**

Status	Open (pulse)	Close (pulse)	Stop	Safe
Closed	Opens and closes after pause time	/	Disables Open and Close	/
Opening	/	Completes opening and then closes	Locks	/
Pause	Recharges pause time	Closes	Locks	Recharges pause time
Closing	Opens	/	Locks	Opens
Locked	Opens	Closes	Disables Open and Close	Disables Close

**EC DECLARATION OF CONFORMITY**

**Manufacturer :** FAAC S.p.A.

**Address:** Via Benini, 1 - 40069 Zola Predosa BOLOGNA - ITALY

**Declares that:** 596/615BPR control board,

- conforms to the essential safety requirements of the following directives:  
73/23/EEC and subsequent amendment 93/68/EEC.  
89/336/EEC and subsequent amendment 92/31/EEC and 93/68/EEC

**Additional note:**

This product underwent tests in a typical uniform configuration (all products manufactured by FAAC S.p.A.).

Bologna, 01 January 2006

The Managing Director

