

Model

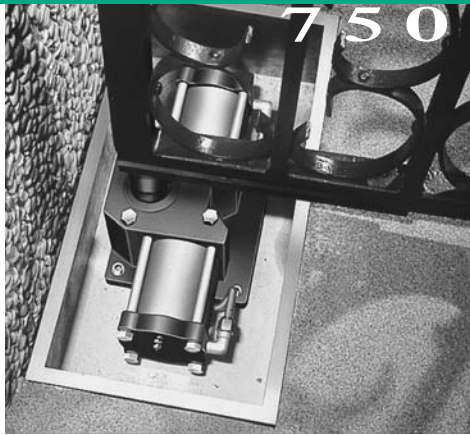

Model 750 Hydraulic Swing Gate Operator

The Model 750 is designed for in-ground installation in residential and light commercial applications. Its power and total invisibility make the 750 ideal for large, ornate gates.

Model 750 operator is controlled by the 450 MPS Control Panel.

- * One 450 MPS operates single leaf or bi-parting gates
- * Choice of 6 operating modes including:
 - "pulse-to-open, pulse-to-close"
 - automatic timed closure, including **NEW HOLD OPEN** function
 - "man present" (separate open and close contacts)
- * Easy interconnection of loop detectors, photocells, etc. to reverse a gate if an obstacle is sensed
- * Easy interconnection of actuating devices like remote control radios, key pads and telephone entry systems
- * On-board diagnostic LEDs

Parameter	Model 750
Application	Residential, light commercial (ideal for ornamental gates) single leaf or bi-parting gate (vehicles only, not for pedestrian use)
Cycles per hour	30
Maximum gate swing	110 degrees or 180 degrees
90 degree opening time	12 seconds
Maximum weight per gate leaf	up to 1760 pounds (800 kg)
Maximum length per gate leaf	Standard leaf: 8 feet (2.4 m) Longer leaf: 13 feet (4 m)
Approx. operating temperature range	-33°F to 165°F (-36°C to 74°C) (For extreme temperature conditions, arctic grade fluid is available upon request)
Hydraulic locking	Standard leaf: Available in opened and/or closed positions Longer leaf: Not available
Voltage	115 VAC (2.5 A) or 230 VAC (1.5 A)

Note: Operator specifications are approximate. Environmental factors can change the performance of the operator. Your installer will advise you which model of operator will work best for your site and application.

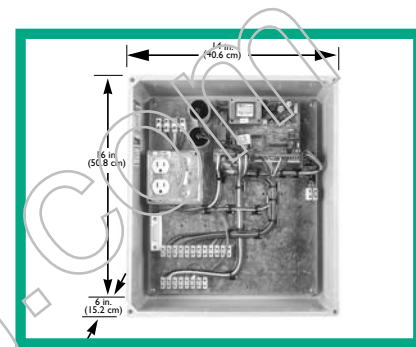

Model 450 MPS Control Panel and fiberglass enclosure (cover not shown)

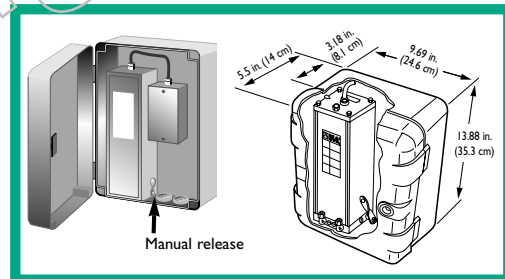

The 750 Pump Motor Assembly and enclosure, which is available with or without hydraulic locking

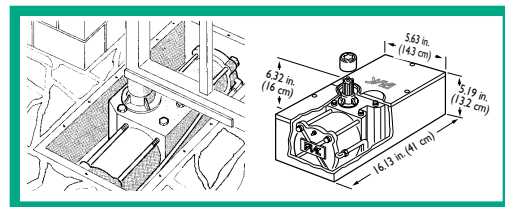

The 750 Drive Unit (with metal enclosure and top) is available in both a 110° swing or a 180° swing version



FAAC is the world's largest specialized manufacturer of operators for barrier, slide and swing gate systems.

The FAAC 750 In-Ground Hydraulic Operator

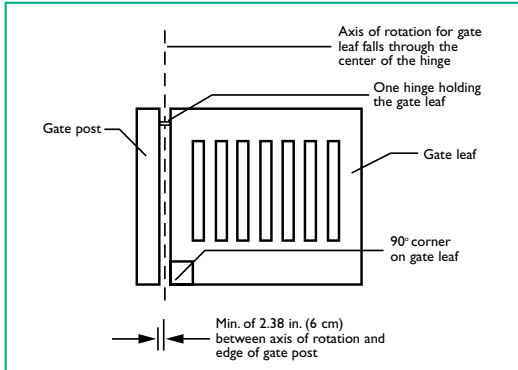

Constraints on the Geometry of the Gate Leaf

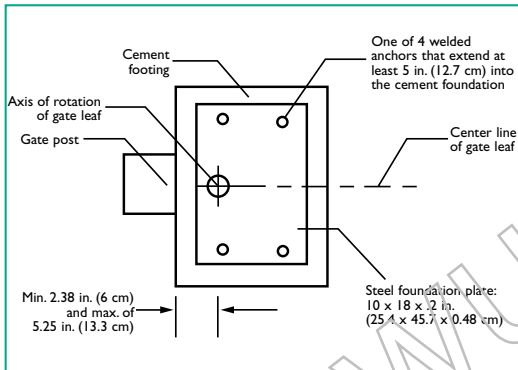

Recommended Dimensions for the Concrete Footing and Foundation Plate (top view)

NOTE: Insure that the cavity where the drive unit is located is well drained by means of pipes, gravel drainage, or both (whatever is appropriate for your soil conditions.)

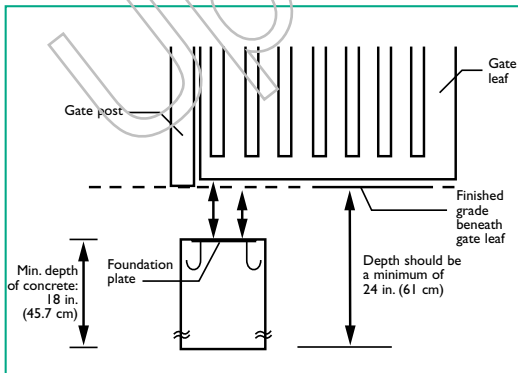

Recommended dimensions for the Concrete Footing and Foundation Plate (side view)

UL Class 325 Descriptions & FAAC Operators			
Class	FAAC Models	Duty Cycle	Typical Use
Class 1	Residential vehicular gate operator 400, 402, 422, 750, 760, 620, 640, 412	Limited duty	*Home use *Small apartment building, up to 4 units per building, limited public access
Class 2	Commercial/General access vehicular gate operator 400, 620, 640	Continuous duty	*Apartment buildings *Open public access
Class 3	Industrial/Limited access vehicular gate operator 400, 620, 640	Continuous Duty	*No public access
Class 4	Restricted Access vehicular gate operator 620, 640	Continuous Duty	*Prison related security

Model 750 Kits include:

- One or two pump motor assemblies
- One or two drive units with metal enclosure and top
- One or two 33 ft lengths of flex hose & one or two connector kits
- One or two foundation plates
- One 450 MPS control panel
- One 14 x 16 in. weather resistant UL listed fiberglass enclosure
- Two photobeam sets for opening and closing reversing devices
- One or two manual release keys
- One plug-in radio receiver
- Two radio transmitters
- 1.5 VAC receptacle for accessories (5 amp max.)
- ON/OFF switch controlling power to control panel, accessories and plug outlet
- Pre-wired for dual photobeams – open and closing reversing devices
- Pre-wired motors to terminal strip
- Pre-wired Open/Hold Open contacts
- Test button
- Two or four warning signs

What the pre-wired system means to an installer:

The pre-wiring system is basically an extension of the control panel. Larger, easier-to-work-with terminal strips are wired from the control panel to locations on the enclosure backplate. When installing, power is run to a terminal strip; motor wires are run to a terminal strip; peripherals (like photobeams) are run to a terminal strip. Each strip has a wiring "map" to ensure easy connections. Anything external has a terminal provided. There is no need to wire anything to the control panel itself. Once connected, all that remains is the fine-tuning of various potentiometers and dip switches on the control panel and the installation is complete.

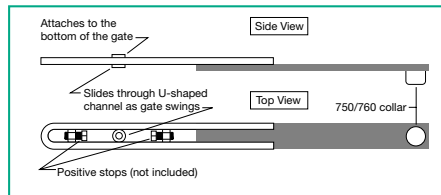

The 750/760 extension arm can be easily modified to act as positive stops. Call FAAC for details.

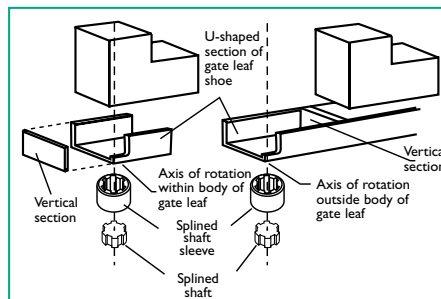

Parts of the Gate Leaf Shoe

For more information, visit our web site at www.faacusa.com, or call 1-800-221-8278.



LIT-750REV-5/01