

770

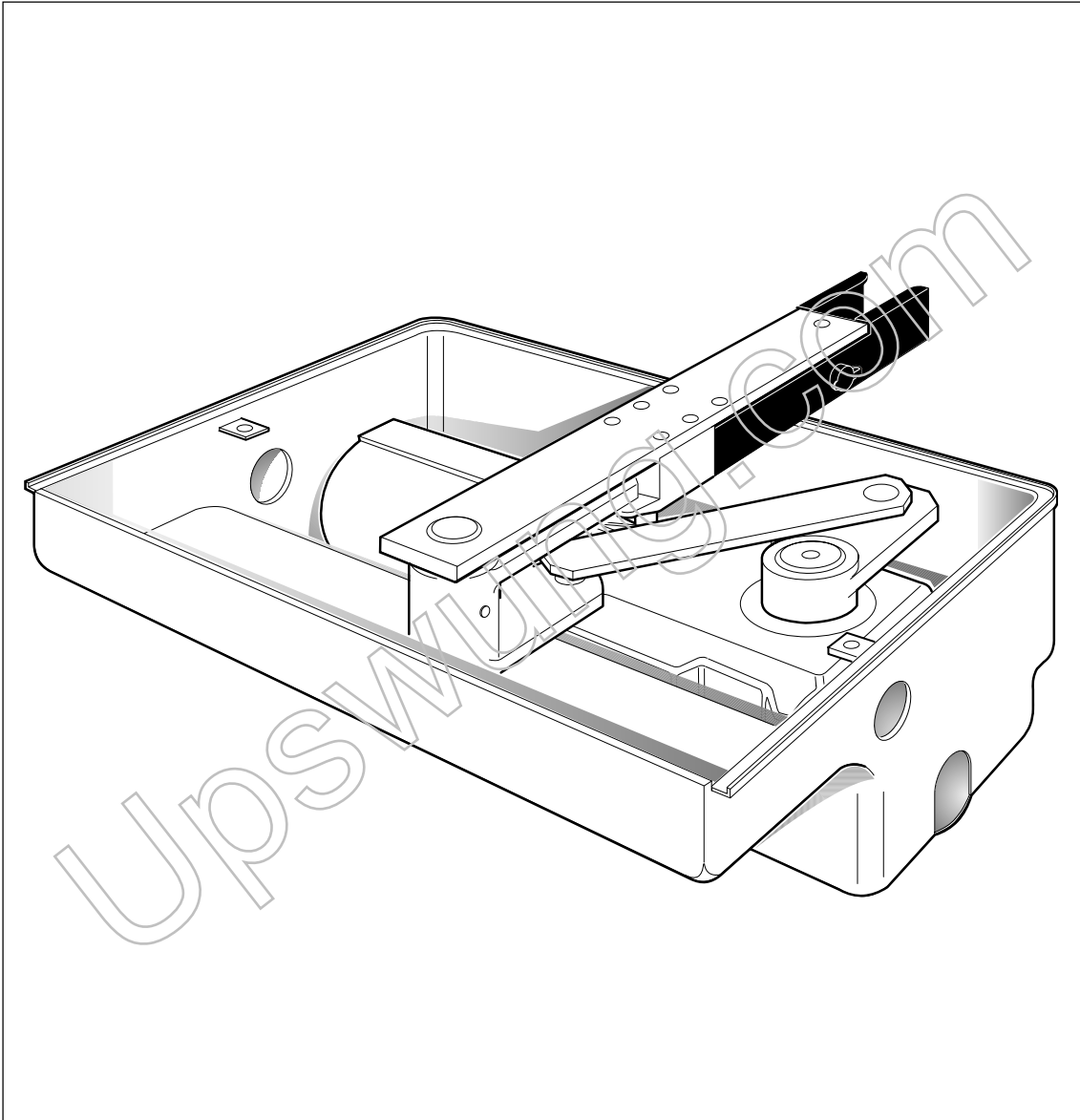

FAAC

EC MACHINE DIRECTIVE COMPLIANCE DECLARATION

(DIRECTIVE 89/392 EEC, APPENDIX II, PART B)

Manufacturer: FAAC S.p.A.

Address: Via Benini, 1
40069 - Zola Predosa
BOLOGNA - ITALY

Hereby declares that: the 770 automation system

- is intended to be incorporated into machinery, or to be assembled with other machinery to constitute machinery in compliance with the requirements of Directive 89/392 EEC, and subsequent amendments 91/368 EEC, 93/44 EEC and 93/68 EEC;
- complies with the essential safety requirements in the following EEC Directives:

73/23 EEC and subsequent amendment 93/68 EEC.
89/336 EEC and subsequent amendments 92/31 EEC and 93/68 EEC.

and furthermore declares that unit must not be put into service until the machinery into which it is incorporated or of which it is a component has been identified and declared to be in conformity with the provisions of Directive 89/392 EEC and subsequent amendments enacted by the national implementing legislation.

Bologna, 1 January 1997

Managing
Director

A. Bassi

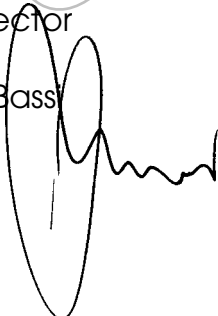

IMPORTANT NOTICE FOR THE INSTALLER

GENERAL SAFETY REGULATIONS

- 1) **WARNING! FAAC strongly recommends to follow these instructions literally for the safety of persons. Improper installation or misuse of the product will cause very serious damages to persons.**
- 2) Packaging material (plastic, polystyrene etc.) is a potential hazard and must be kept out of reach of children.
- 3) Read the instructions carefully before installing the product.
- 4) Keep these instructions for future reference.
- 5) This product has been designed and manufactured only for the use stated in this manual. Any other use not expressly set forth will affect the reliability of the product and/or could be source of hazard.
- 6) FAAC S.p.A. cannot be held responsible for any damage caused by improper use or different from the use for which the automation system is destined to.
- 7) Do not use this device in areas subject to explosion: the presence of flammable gas or fumes is a serious hazard.
- 8) Mechanical constructive elements must comply with UNI8612, CEN pr EN 12604 and CEN pr EN 12605 standards.
Countries outside the EC shall follow the regulations above besides their national normative references in order to offer the utmost safety.
- 9) FAAC cannot be held responsible for failure to observe technical standards in the construction of gates and doors, or for any deformation of the gates which may occur during use.
- 10) Installation must comply with UNI8612, CEN pr 12453 and CEN pr EN 12635.
The degree of safety of the automation must be C + E.
- 11) Before carrying out any operations, turn off the system's main switch.
- 12) An omnipower switch shall be provided for the installation with an opening distance of the contacts of 3 mm or more. Alternatively, use a 6A thermomagnetic breaker with multi-pole switching.
- 13) Ensure that there is a differential switch up-line of the electrical system, with a trip threshold of 0.03A.
- 14) Check that the earthing plant is in perfect condition and connect it to the metallic parts. Also earth the yellow/green wire of the operator.
- 15) The automation is fitted with an anti-crush safety system that is a torque control device. In any case, further safety devices shall be installed.
- 16) The safety devices (e.g. photocells, safety edges, etc.) protect areas where there is a mechanical movement hazard, e.g. crushing, entrapment and cutting.
- 17) Each installation must be fitted with at least one flashing light (e.g. FAAC LAMP, MINILAMP etc) as well as a warning plate suitably fixed to the gate, besides the safety devices as per point 16. above.
- 18) FAAC cannot be held responsible regarding safety and correct functioning of the automation in the event that parts other than FAAC original parts are used.
- 19) Use only FAAC original spare parts for maintenance operations.
- 20) Do not carry out any modifications to automation components.
- 21) The installer must supply all information regarding manual operation of the system in the event of an emergency and provide the end-user with the "End-user Guide" attached to the product.
- 22) Keep out of persons when the product is in operation.
- 23) Keep out of reach of children the remote radio controls and any control devices. The automation could be operated unintentionally.
- 24) The end-user must avoid any attempt to repair or adjust the automation personally. These operations must be carried out exclusively by qualified personnel.
- 25) **What is not explicitly stated in these instructions is not permitted.**

AUTOMATION SYSTEMS 770 COMPACT

The FAAC 770 COMPACT automation system for swing gates is a geared motor. It is designed for underground installation and therefore does not alter the appearance of the leaf.

The foundation box of the automation system comes ready to take an operator.

The 770 electromechanical operator is irreversible, so it ensures a mechanical stop and eliminates the need to install an electric lock.

1. DESCRIPTION AND TECHNICAL CHARACTERISTICS

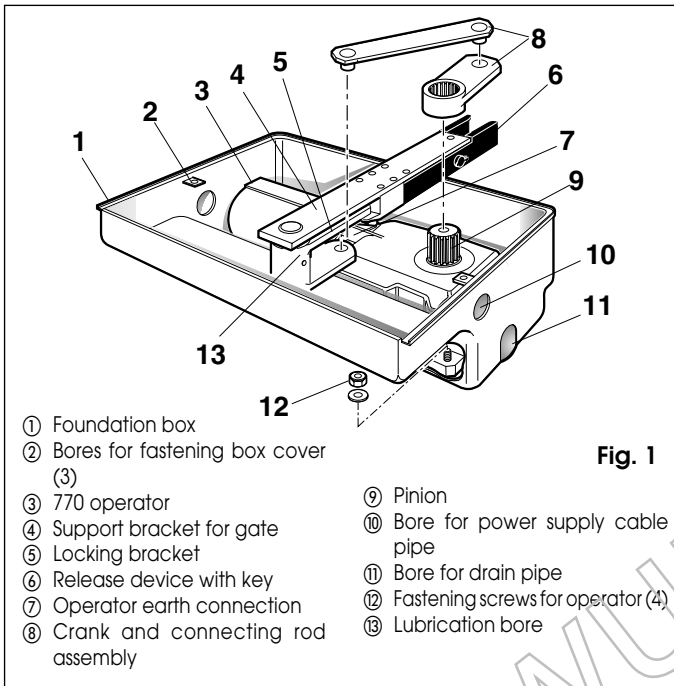

Fig. 1

2. STANDARD INSTALLATION LAYOUT

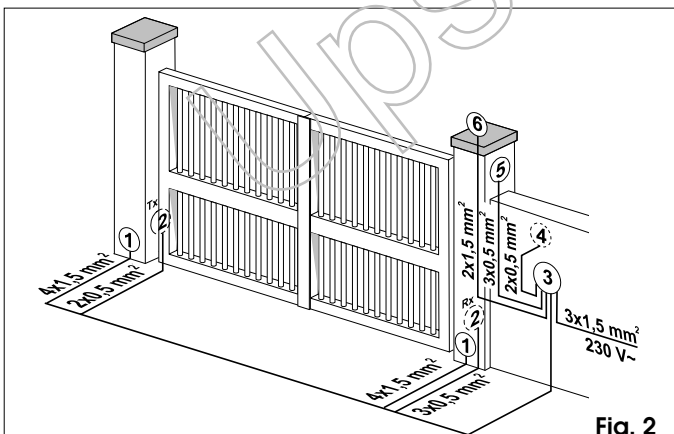

Fig. 2

- ① Operators 770 (require 2 junction boxes)
- ② Photocells
- ③ Control unit
- ④ T10 pushbutton
- ⑤ Receiver
- ⑥ Flashing light

NOTES:

- 1) Use suitable rigid/flexible pipes for laying power cables
- 2) Always keep low voltage accessory cables separate from 230V~ power cables. To avoid interference, use separate sheaths.

Table 1 770 operator technical specifications

	770 SLOW	770	770 24V
Reduction ratio	900:1		1400:1
Motor winding thermal cutout (°C)	140		
Temperature range	-20°C +55°C		
Maximum torque (Nm)	250	330	300
Angular speed (°/sec)	4	6	
Opening time 90° (sec)	27 (110° and 180°) 15 (140°)	18 (110° and 180°) 10,5 (140°)	
Operator weight (Kg)	12 (carrying box 14 Kg)		
Type and frequency of use at 20°C	S3 - 30%		100%
Indicative hour cycles at 20°C	20 (110° and 180°) 36 (140°)	30 (110° and 180°) 50 (140°)	100 (100° and 180°) 170 (140°)
Max. leaf opening angle	110° (140° and 180° with kit)		
Max. leaf weight (kg)	500		
Power cable length (m)	2		
Housing protection	IP 67		
Operator dimensions (mm)	360x150x140		
Max. leaf length (m)	3,5 (110°) - 3 (180°) - 2,5 (140°)		
Electric motor technical specifications			
Power supply	230V~ (+6, -10 %) 50Hz	24Vdc	
Absorbed power (W)	300	380	70
Current drawn (A)	1,3	1,7	3
Electric motor (rpm)	900	1400	
Capacitor	12,5 µF / 400V		
NB: if using leaves of over 2m, install an electric lock to ensure the leaf is locked			

3. INSTALLATION OF THE AUTOMATION SYSTEM

3.1 PRELIMINARY CHECKS

To ensure trouble-free operation, make sure that the gate (whether existing or yet to be installed) has the following specifications:

- max. weight of single leaf 500 Kg
- max. length of single gate leaf 2.5 m
- strong and rigid leaf frame
- smooth gate movement, with no stiff points
- min. clearance between bottom edge of gate and ground as in fig. 6/a (where 's' = thickness of guide bracket)
- mechanical travel stops.

If any welding or brazing has to be done on the gate, do this before installing the automation system.

The condition of the gate directly affects the reliability and safety of the automation system.

3.2 INSTALLATION OF LEAF SUPPORTING FOUNDATION BOX (Fig. 3)

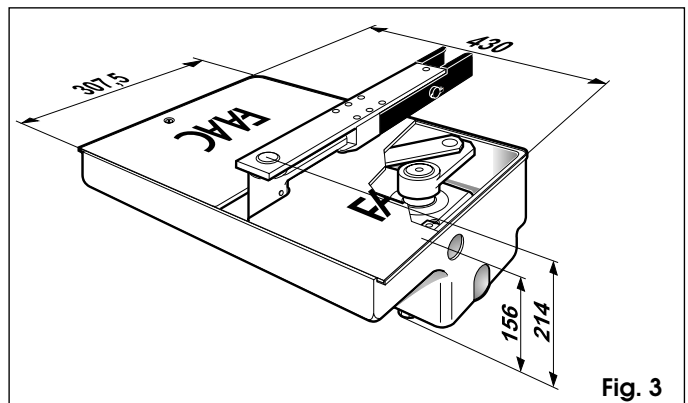

Fig. 3

Proceed as instructed below:

- a) existing gate with fixed hinges
 - Remove the gate.
 - Remove the bottom hinge.

If the gate cannot be removed, place blocks under its bottom edge to support it.

ENGLISH

- b) existing gate with adjustable hinges
 - Remove the bottom hinge.
 - Slacken off the top hinge.
 - Swing the leaf around the axis of the top hinge (fig. 4).
- c) New gate to be installed
 - Fit just the top hinge. If possible use an adjustable hinge.

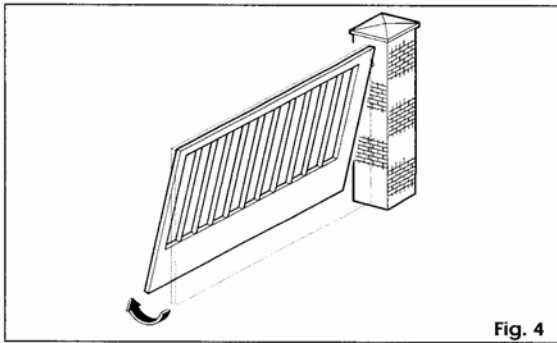

Fig. 4

- 1) Dig out a hole for the foundation box as shown in fig. 5.

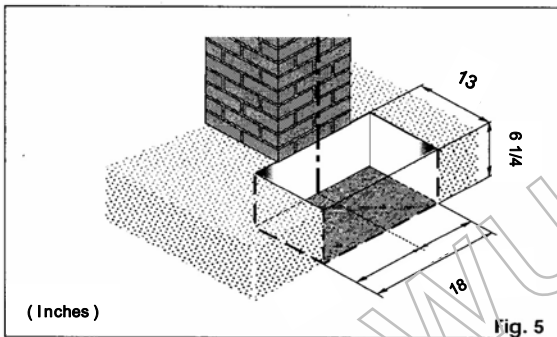

Fig. 5

N.B.: Depending on the nature of the ground, it may be necessary to cast a bed of quick-setting concrete at the bottom of the hole to avoid subsidence in future.

- 2) Place the foundation box in the hole, respecting the dimensions given in fig. 6/a-b. The center of the pivot on the foundation box must be perfectly aligned with the leaf's axis of swing (fig 6/a-b).

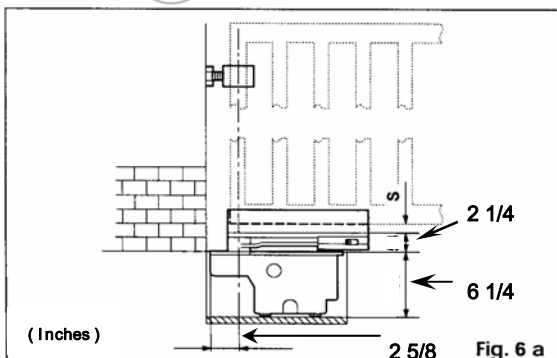

Fig. 6 a

ENGLISH

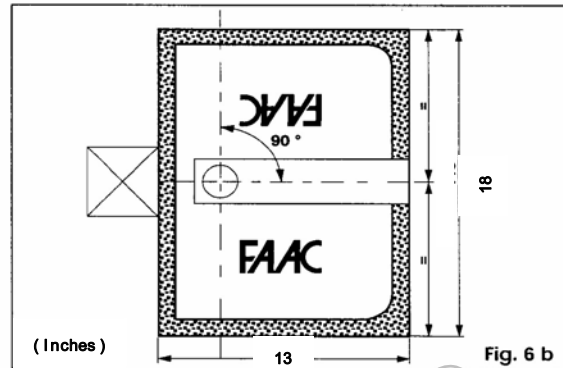

Fig. 6 b

- 3) Lay down a PVC tube of diameter 1-inch through which to pass a 4 core electrical cable. The tube must reach from the box the control unit. (fig 7). Lay a second tube to drain off water, from box to the nearest drain (fig. 7).

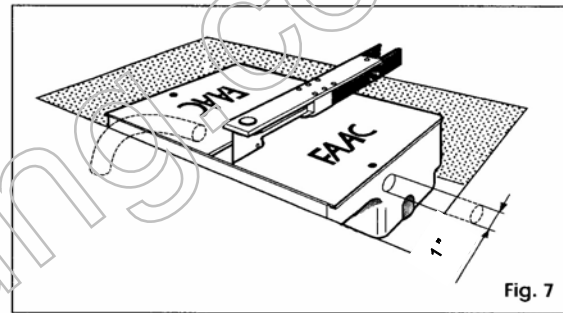

Fig. 7

- 4) Fix the box in place with a casting of concrete.

3.3 SETTING UP THE GATE

Note: Wait for the cement to set before starting this operation.

- 1) Assemble the release levers on the support bracket, and fit the latter on the pivot in the foundation box, also inserting the ball supplied (fig. 8).

Note: Grease both the pivot and the ball.

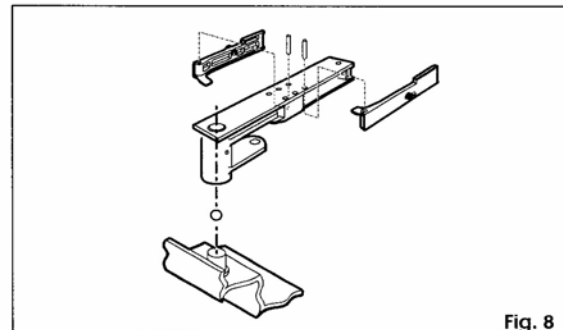

Fig. 8

- 2) Prepare the guide bracket, as follows:
 - use a "U" profile with dimensions indicated in fig. 9;

ENGLISH

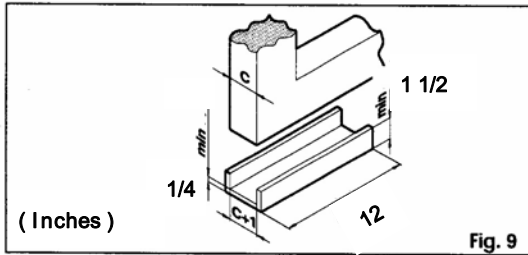

Fig. 9

- ascertain the correct location of the leaf on the "U" profile with reference to the axis of rotation (fig. 10 a-b); seal the "U" profile on the post side with a plate, as shown in fig. 10 a-b.

- Carefully weld the guide bracket to the support bracket (fig. 11).

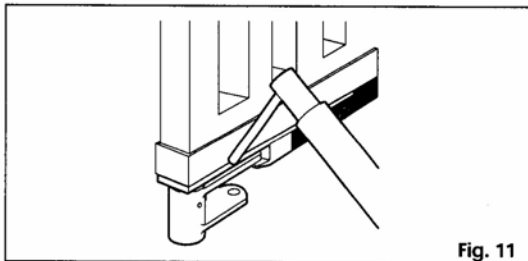

Fig. 11

- Fit the gate into the guide bracket and fix the top hinge in place.

IMPORTANT: To ensure trouble-free operation, do NOT weld the gate leaf to the guide bracket or to the support bracket.

- Manually verify whether the gate opens and closes completely and smoothly, stopping at the mechanical travel stops.

3.4 INSTALLING THE OPERATOR

- Open the gate leaf.
- Place the operator on the fastening screws on the foundation box, and fix it by means of the nuts and washers supplied (fig. 13).

Note: the exact position of the operator is shown in figure 12. In any case the operator pinion must be on the opposite side of leaves opening direction.

- Manually close the leaf and fit the driving levers supplied, as shown in fig. 13.

ENGLISH

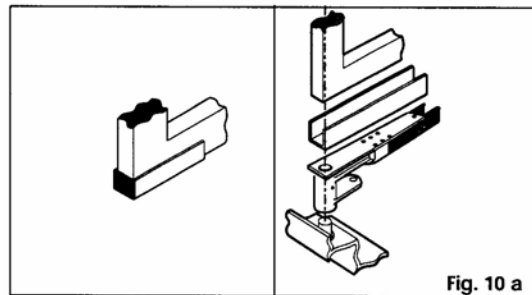

Fig. 10 a

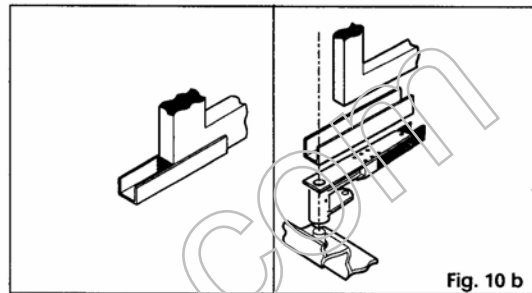

Fig. 10 b

Note: grease the operator pinion and the fixing pivots of the two levers.

- Install the second operator, if required, repeating the operations described above.
- Install the electronic control unit, referring to the dimensions indicated in the relevant instructions.
- Fasten the box cover by means of the screws supplied (fig. 14).

4. START-UP

- Programme the electronic control unit according to your requirements, following the relevant instructions.
- Connect the system to the power supply, and check the status of the LEDs, referring to the table contained in the instructions relevant to the electronic control unit.

5. TESTING THE AUTOMATION SYSTEM

Carefully test the operation of the automation system and of all connected accessories.

Give the customer the User's Guide page, and show him the correct operation and use of the automation system.

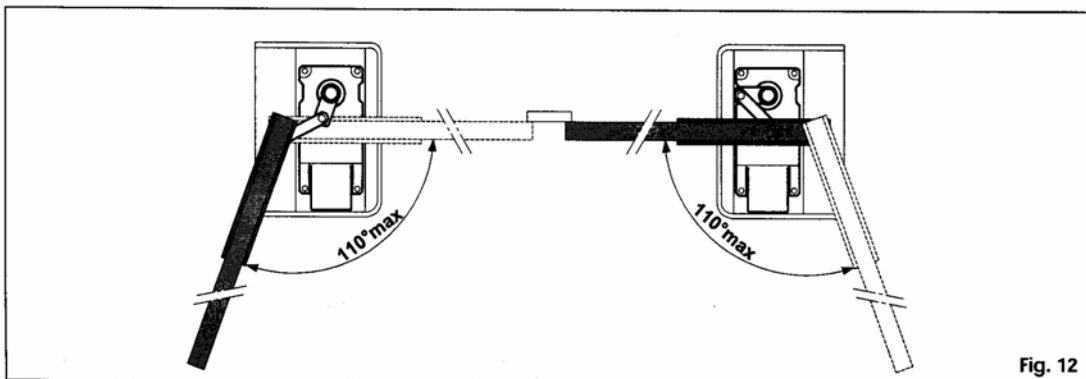

Fig. 12

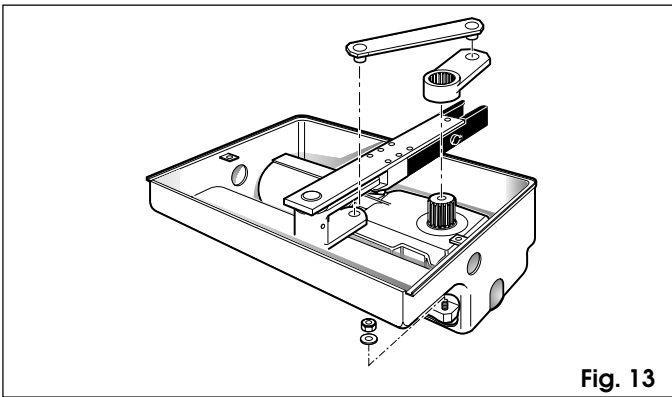

Fig. 13

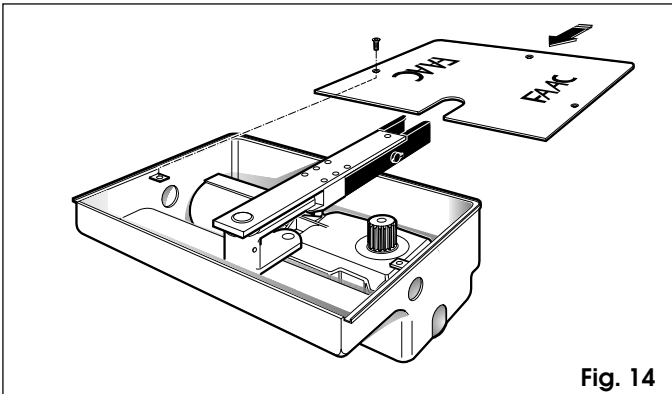

Fig. 14

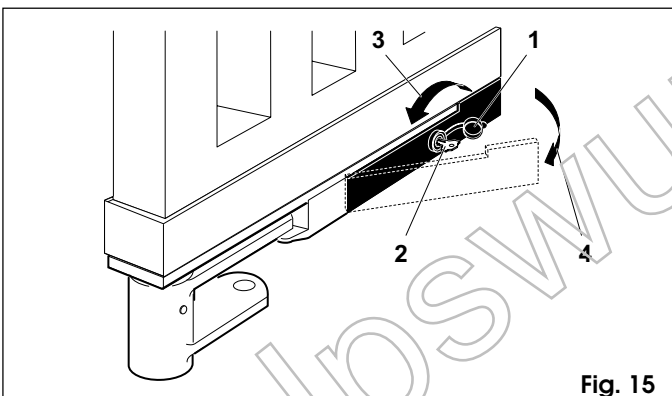

Fig. 15

6. MANUAL OPERATION

Should the need arise to operate the gate manually because of a power failure or malfunction, the release device with key fitted on the support bracket (fig. 1 - ref. 6) makes it possible to release the system both from the inside and from the outside.

To operate the leaf manually, proceed as follows.

- open the lid of the lock (fig. 15-ref. 1);
- insert the release key in the lock (fig. 15-ref. 2);
- turn the key in the direction of the post, as far as it will go (fig. 15-ref. 3);
- pull the lever out (fig. 15-ref. 4);
- operate the leaf manually.

7. RETURNING TO NORMAL OPERATION

To restore normal operation, proceed as follows:

- push the lever back into its home position (fig. 16-ref. 1);
- insert the release key in the lock and turn it in the direction opposite the post, as far as it will go (fig. 16-ref. 2);

- operate the leaf manually until the lock is engaged in the locking bracket (fig. 16-ref. 3);
- close the lid of the lock.

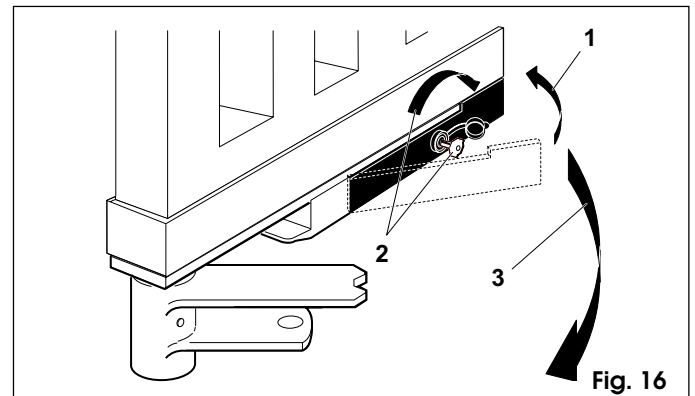

Fig. 16

8. MAINTENANCE

At regular intervals, check the structure of the gate and make sure that the hinges are in perfect working order. Periodically lubricate the pivot and ball in the support bracket, through the lubricating bore shown in fig. 1-ref. 13. Make sure that the pivots of the lever systems, the pinion and the engagement of the lock on the locking bracket (fig. 1 - ref. 5) are always well lubricated, and check the efficiency of the manual operation.

Whenever you perform a maintenance operation, check that the anti-crushing system and the safety devices installed on the automation system are correctly set.

9. REPAIRS

For repairs, refer to authorised FAAC service centres.

END-USER GUIDE

770 Compact Automation Systems

Read the end user guide carefully before using the product and keep it in a safe place for future reference.

GENERAL SAFETY REGULATIONS

When correctly installed and used, the 770 Compact automation system ensures a high degree of safety. A few simple rules should be followed to prevent accidental problems.

- Do not pass between the leaves when they are still moving; always wait until they have opened completely.
- Do not linger between the leaves.
- Do not linger near the automation system; do not allow children or adults to linger near it; and do not leave objects near it.
- Keep wireless control devices, or other devices that might accidentally activate the automation system, out of the reach of children.
- Do not allow children to play with the automation system.
- Do not impede the movement of the leaves.
- Do not allow branches or bushes to interfere with the movement of the leaves.
- Ensure that the warning lamps are in always in working order and visible.
- Do not attempt to actuate the leaves manually unless you have first unlocked them.
- In case of a malfunction, unlock the leaves to allow vehicles to pass, and call a qualified technician.
- If you have set the manual mode, before restoring normal operation, disconnect the power supply.
- Do not modify the components of the automation system.
- Do not attempt to repair the automation system or to perform any operation on it. Call qualified technicians only.
- At least once every 6 months, have qualified personnel check that the automation system, safety devices and earth connection are in working order.

DESCRIPTION

The FAAC 770 Compact automation system for swing gates is a geared motor. It is designed for underground installation and therefore does not alter the appearance of the leaf. The operators are controlled by an electronic control unit mounted in an enclosure which assures adequate protection against atmospheric agents.

The leaves are normally closed. When the electronic control unit receives an open command from the remote radio control or any other control device, it activates the electromechanical system and causes the leaves to rotate by an angle of up to 110° to their open position, so as to allow access.

If automatic operation has been selected, the leaves close automatically after the selected pause time.

If semiautomatic operation has been selected, a second impulse must be sent to close the leaves.

An open command given while the leaves are closing causes the leaves to reverse direction of movement.

A stop command (if available) stops movement at any time.

For detailed information on the operation of the automation system in the various operating modes, contact the installation technician.

The automation system is equipped with a safety device consisting of photocells. When the photocells are darkened

by an obstacle, they prevent the leaves from closing.

The 770 Compact automation system is also equipped with an anti-crushing safety device (fitted as standard) that limits the torque transmitted to the leaves.

The operators ensure that the system is mechanically locked when the motor is not running, so there is no need to install a lock.

The leaves can be opened manually only by operating the unlocking device.

The lamp flashes while the leaves are moving.

MANUAL OPERATION

Should the need arise to operate the gate manually because of a power failure or malfunction, the release device with key.

To operate the leaf manually, proceed as follows.

- open the lid of the lock (fig. 1-ref. 1);

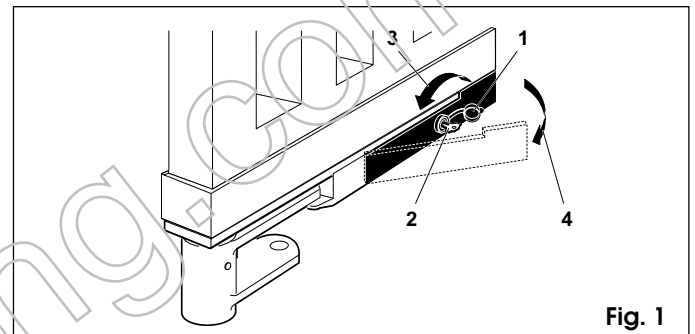

Fig. 1

- insert the release key in the lock (fig. 1-ref. 2);
- turn the key in the direction of the post, as far as it will go (fig. 1-ref. 3);
- pull the lever out (fig. 1-ref. 4);
- operate the leaf manually.

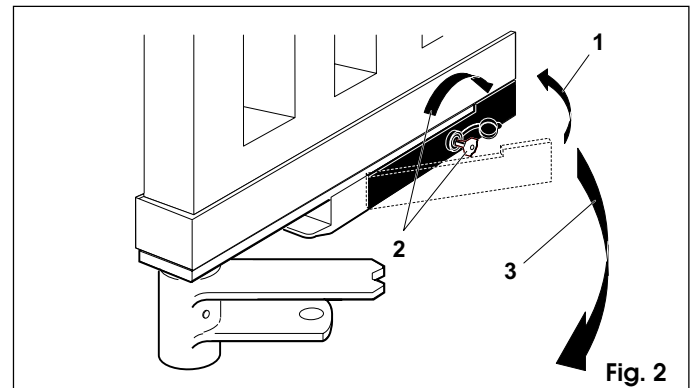

Fig. 2

RETURNING TO NORMAL OPERATION

To prevent an accidental impulse from activating the operators during this operation before you re-lock the operators, disconnect the system from power supply.

To restore normal operation, proceed as follows:

- push the lever back into its home position (fig. 2-ref. 1);
- insert the release key in the lock and turn it in the direction opposite the post, as far as it will go (fig. 2-ref. 2);
- operate the leaf manually until the lock is engaged in the locking bracket (fig. 2-ref. 3);
- close the lid of the lock.