

400/402/422 PANTOGRAPH

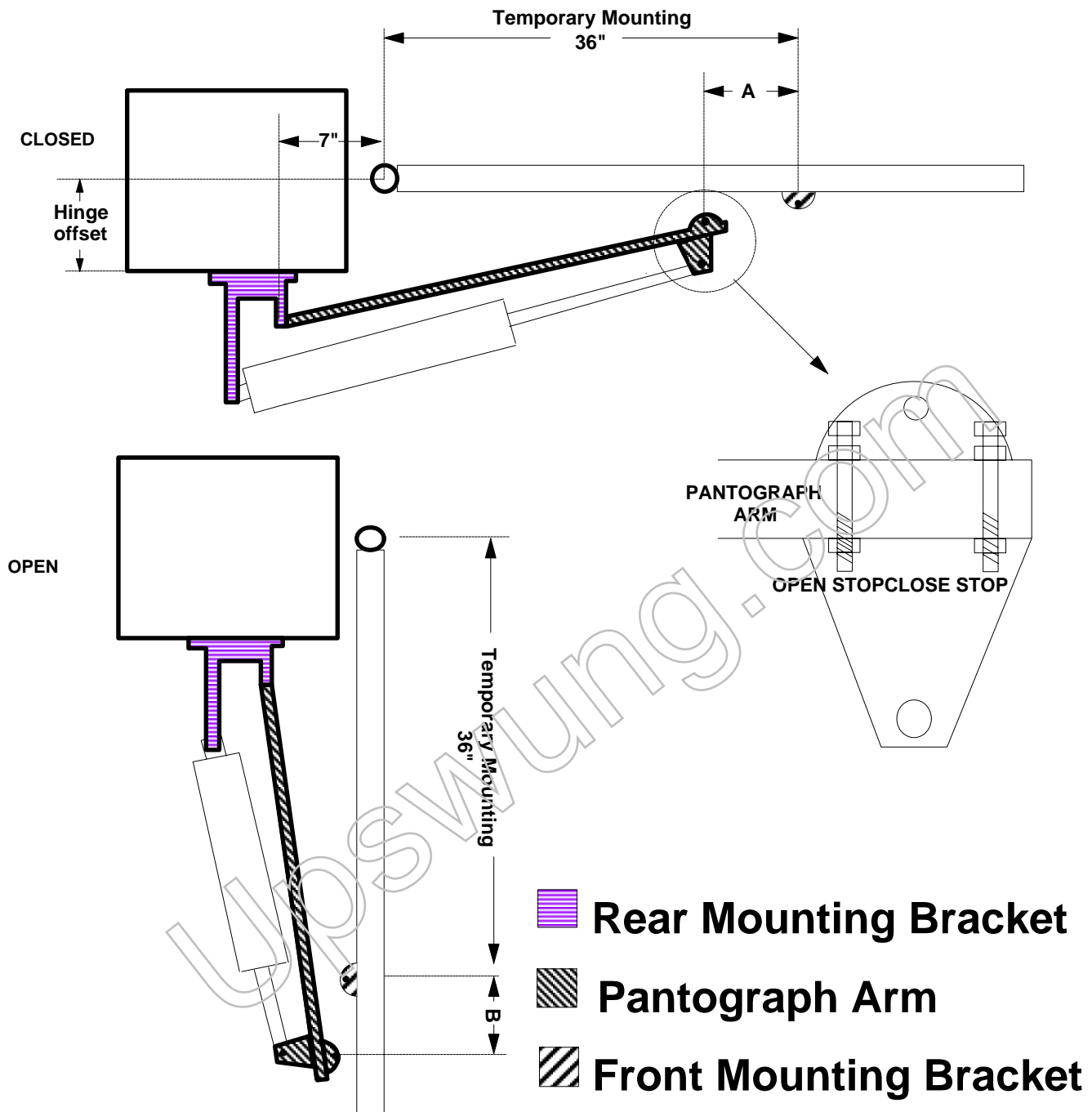

ADD DIMENSIONS A & B TOGETHER. DIVIDE THIS SUM BY 2, RESULTING IN THE LENGTH OF THE LINK CONNECTING THE PANTOGRAPH ARM TO THE FRONT MOUNTING BRACKET . AFTER DRILLING AND CUTTING THE CONNECTING LINK INSTALL THE FRONT BRACKET ACCORDINGLY.

NOTE: MAXIMUM OFFSETS - (400 -18") (402 / 422 -12")