

# SWG

## INSTALLATION GUIDE

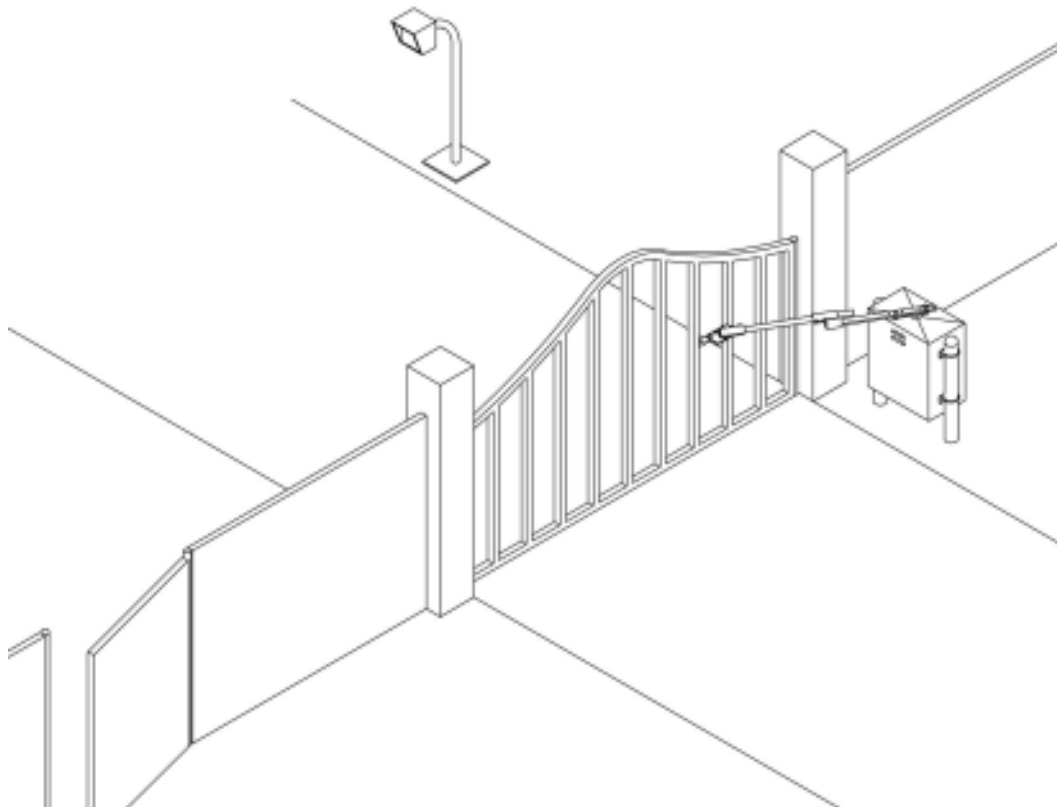

# OSCO<sup>®</sup>

**OPERATOR SPECIALTY COMPANY, INC.**

CASNOVIA, MI 49318 • U.S.A.



**UL325 COMPLIANCE REQUIRES THE USE OF CONTACT EDGES  
OR PHOTOELECTRIC CONTROLS ON ALL AUTOMATIC OR  
REMOTELY-CONTROLLED GATE OPERATORS.**

# SWG OPERATOR INSTALLATION GUIDE

## TABLE OF CONTENTS

### PRE-INSTALLATION INFORMATION

Gate Operator Classifications .....	3
Safety Information and Warnings .....	3
Pre-Installation Information .....	3
Warranty .....	3

### INSTALLATION

Wiring Specifications .....	4
Post Mounting Instructions .....	5
String Method for Nonstandard Installation of Swing Gate Operators .....	6
Articulating -Style Arm Assembly Instructions .....	7
Vent Plug Installation .....	8
Torque Limiter Adjustment .....	8
Electrical Connection and Adjustments .....	9
Limit Cam Adjustments .....	9

### CONTROL BOARD ADJUSTMENTS and ACCESSORY CONNECTIONS

Control Board Adjustments .....	10
Terminal Connection Descriptions .....	11
Current Sensing Adjustments .....	12
Close Direction Current Sense Adjustment .....	12
Open Direction Current Sense Adjustment .....	12
Maximum Run Timer Adjustment .....	12
Auto Close Timer Adjustment .....	12
Master/Slave Connection .....	12
Onboard L.E.D. Indicator Descriptions .....	13
Important Notes for Installation of Master/Slave Applications .....	14
Surge Protector Instructions .....	14
Control and Accessory Connection Illustrations .....	15-18

### ILLUSTRATIONS

Loop Layout Illustration .....	19
Edge Layout Illustration #1 .....	20
Photo Eye Illustration .....	21

### TROUBLESHOOTING

.....	22
-------	----

### PARTS LISTS

How to Order Replacement Parts .....	22
Model SWG Mechanical Parts Exploded View .....	23
Model SWG Mechanical Parts List .....	24
Model SWG Single Phase Control Box Exploded View and Parts List .....	25
Model SWG Three Phase Control Box Exploded View and Parts List .....	26
Model SWG Gate Arm Assembly Parts List .....	27

### PREVENTATIVE MAINTENANCE

.....	29
-------	----

### GATE OPERATOR INSTALLATION CHECKLIST

.....	30
-------	----

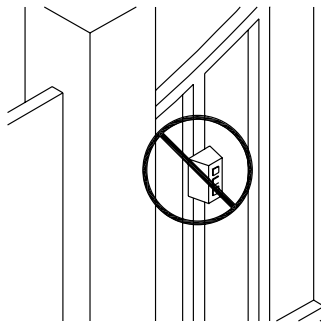

**CAUTION!**  
DO NOT INSTALL  
CONTROLS ON OR  
NEAR THE GATE

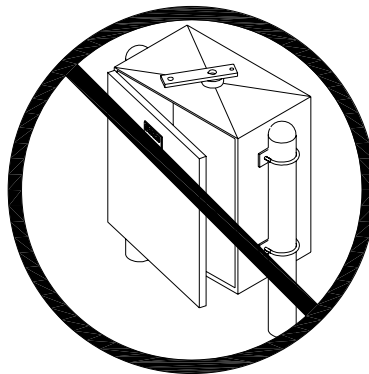

**CAUTION!**  
ONLY QUALIFIED SERVICE  
TECHNICIANS SHOULD  
WORK ON AN OSCO  
SWING GATE OPERATOR

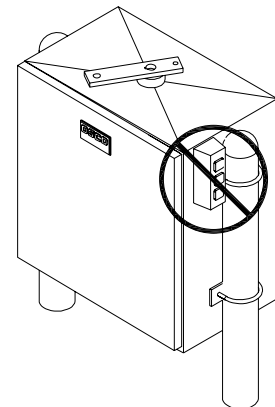

**CAUTION!**  
DO NOT INSTALL  
CONTROLS ON  
THE OPERATOR

# SWG OPERATOR INSTALLATION GUIDE

## GATE OPERATOR CLASSIFICATIONS

All gate operators can be divided into one of four different classifications, depending on their design and usage.

### **Class I Residential Vehicular Gate Operator**

A vehicular gate operator intended for use in a home of one to four single family dwellings, or garage or parking area associated with these dwellings.

### **Class II Commercial / General Access Vehicular Gate Operator**

A vehicular gate operator intended for use in a commercial location or building such as a multifamily housing unit of five or more single family units, hotel, retail store or other building servicing the general public.

### **Class III Industrial / Limited Access Vehicular Gate Operator**

A vehicular gate operator intended for use in an industrial location or building such as a factory or loading dock area or other location not intended to service the general public.

### **Class IV Restricted Access Vehicular Gate Operator**

A vehicular gate operator intended for use in a guarded industrial location or building such as an airport security area or other restricted access locations not servicing the general public, in which unauthorized access is prevented via supervision by security personnel.

## **IMPORTANT!!**

Before installing the gate operator, make sure the gate's swing is free and level throughout the entire swing path. If the gate does not seem to operate properly, it may affect the operator performance or greatly shorten the life of the unit. The gate should be designed so that airflow is ample to prevent wind resistance and drag.



## SAFETY INFORMATION AND WARNINGS

Read the following before beginning to install OSCO swing gate operators:

1. Read the orange "Safety Instructions" brochure enclosed with the packet of information. If you do not have one, please call OSCO at 1-800-333-1717 to request one. Read and follow all instructions.
2. All electrical connections to the power supply must be made by a licensed electrician and must observe all national and local electrical codes.
3. A separate power-disconnect switch should be located near the operator so that primary power can be turned off when necessary.
4. Install the enclosed warning signs on both sides of the gate. Each sign must be plainly visible from the side of the gate on which they are mounted.
5. Never reach between, through or around the fence to operate the gate.
6. You must install all required safety equipment.

## PRE-INSTALLATION INFORMATION

Before unpacking, inspect the carton for exterior damage. If you find damage, advise the delivery carrier of a potential claim. Inspect your package carefully. You can check your accessory box parts with the enclosed packing slip for your convenience. Claims for shortages will be honored for only 30 days from the date of shipment.

Before installing the operator, read this manual completely to ensure all requirements for proper installation are present. Verify that the voltage to be used matches the voltage of the operator.

**The following contact or non-contact obstruction detection devices have been approved for use with OSCO slide gate operators as part of a UL325 compliant installation:**

#### **Contact Edges:**

Miller Models\*: MG0-20, MGR-20, MGS-20, and ME-120

#### **Photoeyes:**

2520-441 MMTC Model IR-55 photoeye, 165' with mounting hardware

2520-031 MMTC Model E3K photoeye, 28' with mounting hardware

*\*for OSCO part numbers, contact a sales representative for details*

# SWG OPERATOR INSTALLATION GUIDE

## WIRING SPECIFICATIONS

- Select from the chart at the bottom of this page corresponding to the model, voltage and horsepower rating of your operator.
- The distance shown on the chart is measured in feet from the operator to the power source. **DO NOT EXCEED THE MAXIMUM DISTANCE.** These calculations have been based on standard 115V and 230V supplies with a 10% drop allowable. If your supply is under the standard rating, the runs listed may be longer than what your application will handle, and you should not run wire too near the upper end of the chart for the gauge of wire you are using.
- When large-gauge wire is used, a separate junction box (not supplied) may be needed for the operator power connection.
- All control devices are now 24VDC, which can be run considerable distances. 24VAC is available for other devices, such as loop detectors and photo eyes.
- Wire run calculations are based on the National Electrical Code, Article 430 and have been carefully determined based on motor inrush, brake solenoids, and operator requirements.
- Connect power in accordance with local codes. **The green ground wire must be properly connected.**
- Wire insulation must be suitable to the application.
- Control wiring must be run in a separate conduit from power wiring. Running them together may cause interference and faulty signals in some accessories.
- Electrical outlets are supplied in all 115VAC models for convenience with occasional use or low power consumption devices only. If you choose to run dedicated equipment from these devices, it will decrease the distance for maximum run and the charts will no longer be accurate.
- A three-wire shielded conductor cable is required to connect master and slave operators. You must use Belden 8760 Twisted Pair Shielded Cable (or equivalent) **only** – OSCO part number 2500-1982, per foot). See page 10 for details of this connection, as well as dip switch selection. **Note: The SHIELD wire should be connected in both the master and slave operators.**

## USE COPPER WIRE ONLY!

### MODEL SWG – SINGLE PHASE

Power Wiring											
Volts & HP	Max Distance		Wire Gauge	Volts & HP	Max Distance		Wire Gauge	Volts & HP	Max Distance		Wire Gauge
	Single	Dual			Single	Dual			Single	Dual	
115V	222	111	12	208V	760	380	12	230V	894	447	12
	354	177	10		1200	600	10		1422	711	10
	566	283	8		1924	962	8		2264	1132	8
1/2 HP	900	450	6	1/2 HP	3060	1830	6	1/2 HP	3600	1800	6
	1430	715	4		4864	2432	4		5724	2862	4
115V	178	89	12	208	604	302	12	230V	710	355	12
	282	141	10		958	478	10		1128	564	10
	450	225	8		1526	763	8		1796	898	8
3/4 HP	716	358	6	3/4 HP	2424	1212	6	3/4 HP	2852	1426	6
	1140	570	4		3856	1928	4		4538	2269	4
115V	160	80	12	208V	544	272	12	230V	640	320	12
	254	127	10		864	432	10		1016	508	10
	406	203	8		1374	686	8		1616	808	8
	646	323	6		2184	1092	6		2570	1285	6
	1026	513	4		3476	1738	4		4090	2045	4
1HP				1HP				1HP			

### ACCESSORY WIRING

All Models		
Volts	Maximum Distance (ft.)	Wire Gauge
24VAC	250	14
	350*	12
24VDC	0-2000	14
*Over 350 ft. use DC power.		

### MODEL SWG – THREE PHASE

Power Wiring: 3 Phase											
Volts & HP	Max Distance		Wire Gauge	Volts & HP	Max Distance		Wire Gauge	Volts & HP	Max Distance		Wire Gauge
	Single	Dual			Single	Dual			Single	Dual	
208V 1/2 HP	1142	571	12	230V 1/2 HP	1344	672	12	460V 1/2 HP	3841	1921	12
	1816	908	10		2137	1069	10		6106	3053	10
	2890	1445	8		3400	1700	8		9712	4856	8
208V 3/4 HP	920	460	12	230V 3/4 HP	1084	542	12	460V 3/4 HP	3279	1640	12
	1464	732	10		1723	862	10		5212	2606	10
	2330	1165	8		2741	1371	8		8291	4146	8
208V 1HP	714	357	12	230V 1HP	840	420	12	460V 1HP	2689	1345	12
	1136	568	10		1336	668	10		4274	2437	10
	1804	902	8		2124	1062	8		6798	3399	8

# SWG OPERATOR INSTALLATION GUIDE

## POST MOUNTING INSTRUCTIONS FOR MODEL SWG

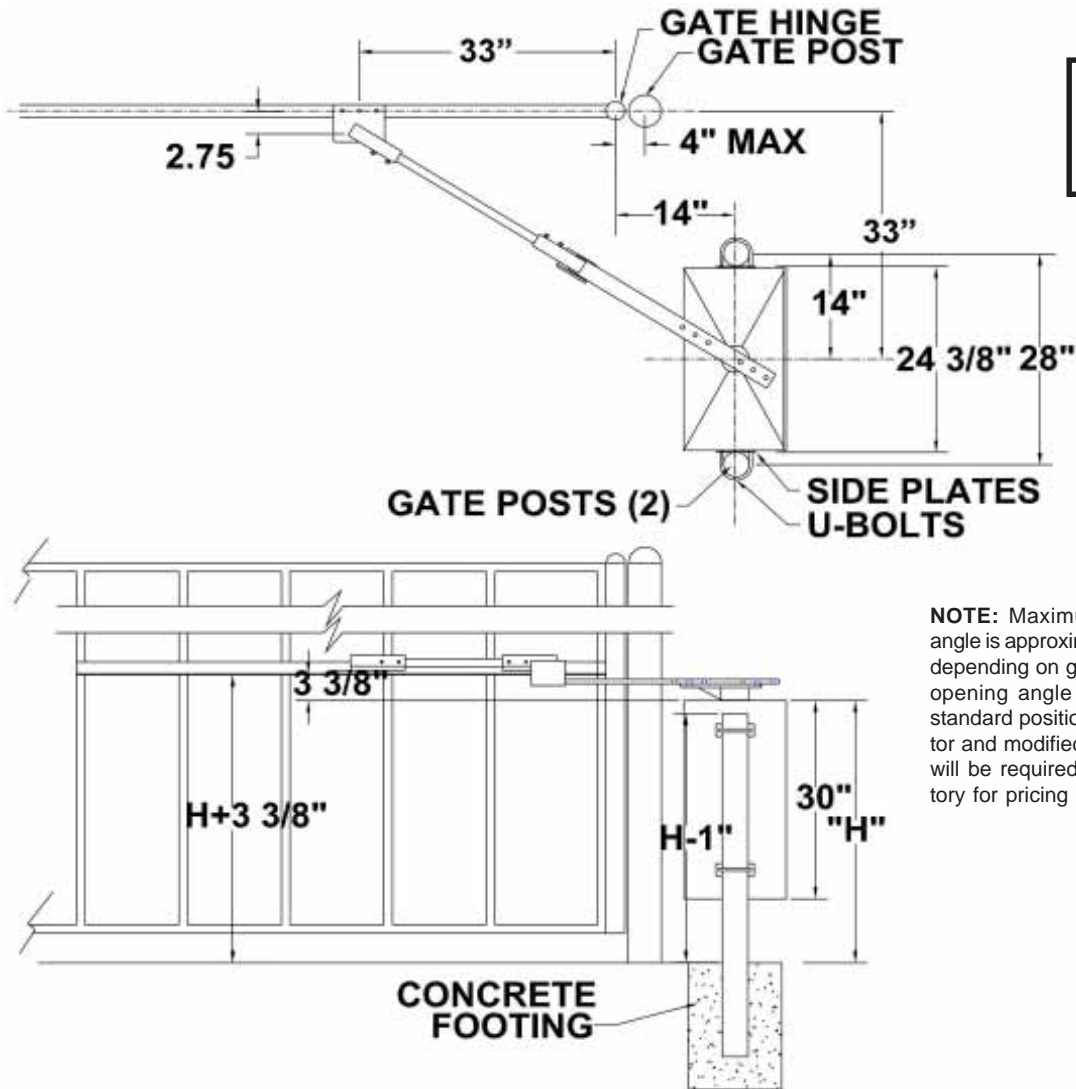

**DOOR MUST FACE AWAY FROM DRIVEWAY**

**NOTE:** Maximum gate opening angle is approximately 95 degrees, depending on gate width. If larger opening angle is required, non-standard positioning of the operator and modified articulating arms will be required. Contact the factory for pricing and availability.

Use two 3 - 3 1/2" diameter galvanized posts and secure with concrete footings as shown, length to be determined by local codes, frost line depth, and soil conditions.

Attach the operator with the U-bolts, side plates and hardware provided. There are four side plates. The 3/16" side plates go on the inside top of the operator, while the two 1/2" side plates go on the inside bottom (see the illustration at right). The operator should be positioned at a level to allow the arm to be installed at mid-height on the gate. "H" dimension can vary depending on gate construction. Make sure the posts do not protrude above the operator cabinet.

Assemble the arm components as shown on page 7.

**23" SPACE REQUIRED BEHIND OPERATOR FOR ARM CLEARANCE WHILE OPENING**

**IF NONSTANDARD MOUNTING IS NECESSARY, CONSULT THE FACTORY**

**A SEPARATE PEDESTRIAN GATE IS REQUIRED FOR ALL PEDESTRIAN TRAFFIC. THIS GATE MUST BE A MINIMUM DISTANCE OF 7 FEET FROM THE VEHICULAR GATE AND GATE OPERATOR**

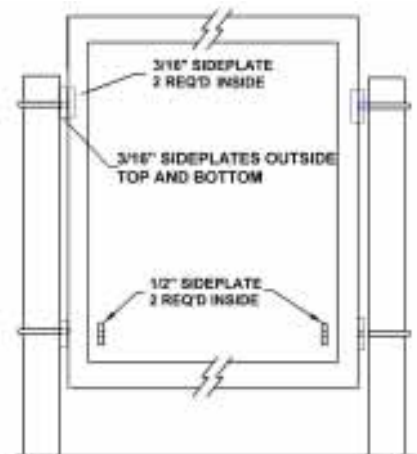

**SIDE PLATE INSTALLATION**

# SWG OPERATOR INSTALLATION GUIDE

## STRING METHOD FOR NONSTANDARD INSTALLATION OF SWING GATE OPERATORS

### Step A: Position the Operator

1. Connect the gate plate assembly onto the gate at the recommended location for a standard installation (Dimension "W").
2. Open the gate to its fully-open position.
3. Position the operator parallel to the gate. The distance from the operator output shaft to the gate plate pivot point is shown at right. The operator should be positioned the same distance from the gate hinge as the gate plate has been; ie: the "W" dimension.

### Step B: Measure the Crank Extension and Link Center to Center Distances

1. Close the gate.
2. Using a piece of tape, attach a string to the top of the operator output shaft, at its center. Holding the string taut and using another piece of tape, hold the other end of the string across the hole in the gate plate. This distance is Dimension 1. Carefully measure this dimension and write it down.
3. Open the gate.
4. Pick up the string, while it is still attached at both ends, and pull it taut again while positioning it directly over the center of the operator shaft, at Point "B," and work your way back along the string until you reach Point "C."
5. While holding the string taut, measure the distance from Point "B" to Point "C." This is the required center to center distance for the crank extension.
6. Measure the distance from Point "A" to Point "C." This is the required center to center distance for the link section.
7. When added together, the distances from Point "A" to Point "B" and Point "B" to Point "C" should equal the Dimension 1 measurement.

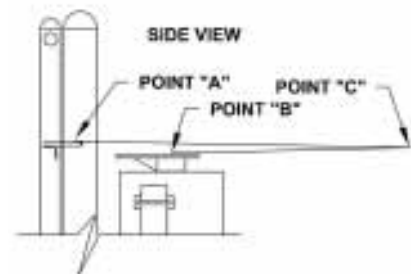
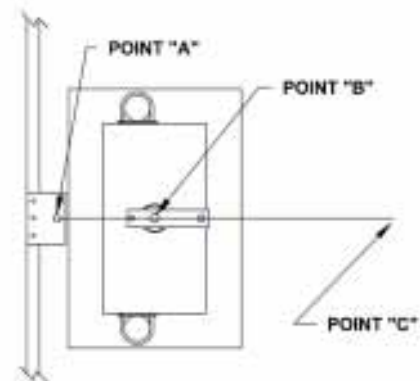
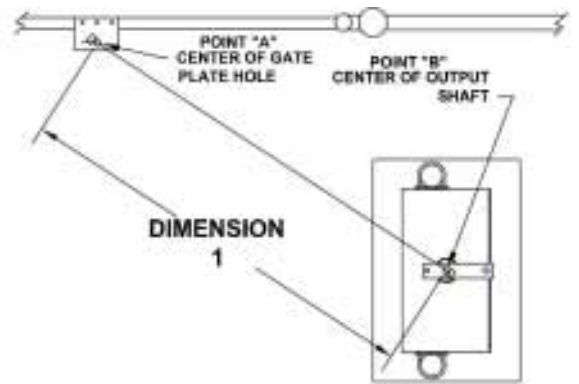
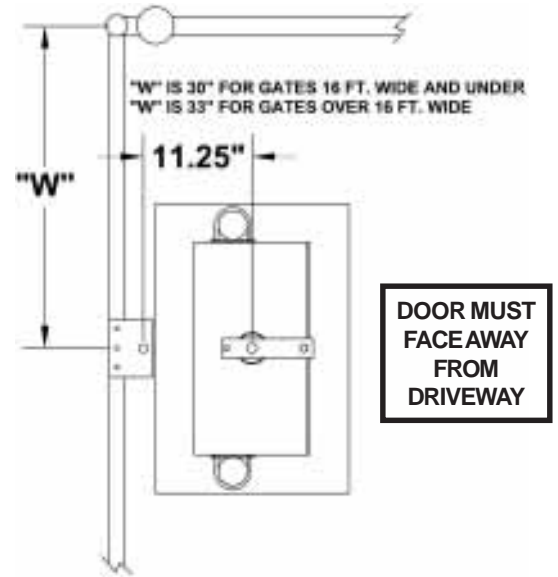

These measurements will be needed when placing an order for special length crank extensions and links. Also note that the measurements you have just calculated are center to center only, and are not overall dimensions, which would also include other attachment hardware, such as gate arm clamps.

It is also possible that both open and closed limit switches may be activated at either end of gate travel due to the total gate travel required, and the shape of the limit switches and cams. This problem can be corrected by carefully bending the limit switch arm slightly and readjusting its cam.

**PLEASE NOTE:** Your operator may look different when installed. The drawings on this page are for general reference only.

# SWG OPERATOR INSTALLATION GUIDE

## ARTICULATING-STYLE ARM ASSEMBLY INSTRUCTIONS FOR MODEL SWG

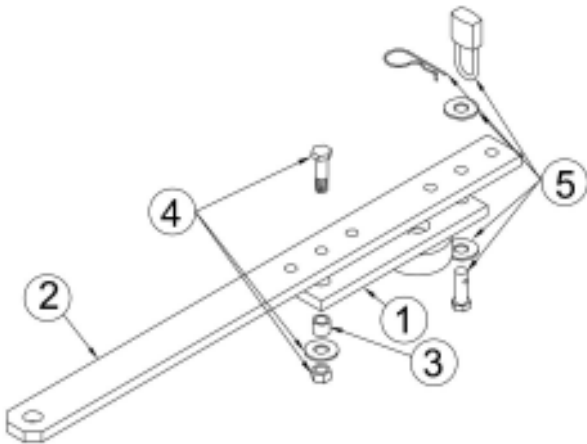

Numbered items in these drawings are for instructional reference only. For actual part numbers, go to the parts lists in the back of this booklet.

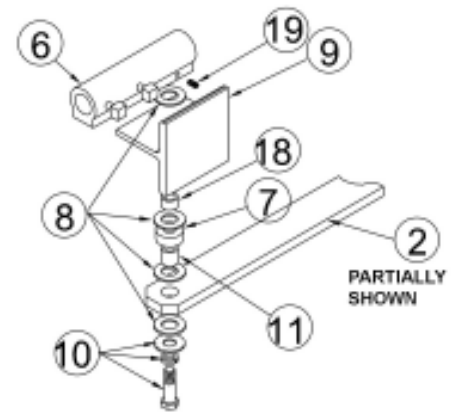

Place the crank extension (2) on the operator crank (1) as shown. Slide a black spacer (3) into the crank and hold it while sliding a 1/2-13 x 1 3/4" hex head bolt (4) through the extension and crank. Assemble with a 1/2" flat washer and locknut and tighten. Slide the clevis pin (5) and a 1/2" flat washer through the crank and the extension. Slide another 1/2" flat washer over the end of the pin and lock it with either a disconnect pull pin or with an optional pad lock through the pin.

Slide a 1/2" lockwasher and flatwasher onto the 1/2-13 x 2 1/2" hex head bolt (10). Add a nylon washer (8), then slide the bolt through the crank extension (2) and hold in place. Next, insert the yellow-plated pivot spacer (11) into the crank extension, add a nylon washer (8) and place the offset spacer (7) on top of the nylon washer. Add a nylon washer (8) to the top of the offset spacer (7) and add the silver zinc-finish overtravel stop spacer (18). Slide the overtravel stop bracket (9) over the silver zinc-finish spacer and add the last nylon washer (8) above the bracket. Carefully screw the bolt assembly into the aluminum gate clamp (6) until the lockwasher has been fully compressed. The overtravel stop and crank extension should float freely, without binding, when it is fully assembled. Tighten set screw (19) to further lock hex bolt (10) in place.

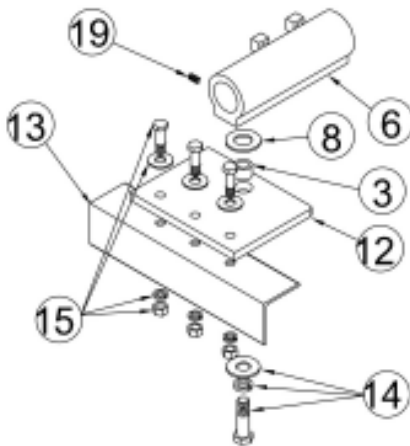

Angle iron (not supplied) (13) should be welded to the gate prior to this step. Attach the gate plate (12) to the angle iron using 3/8 bolts, flat washers, lock washers and hex nuts (15). Slide a 1/2-13 x 1 1/4" bolt, 1/2" lock washer, 1/2" flat washer (14), and a black spacer (3) through the gate plate. Place a nylon washer (8) over the opening in the gate plate. Thread the bolt into the hole in the gate clamp (6) and tighten carefully. **Do not overtighten!** Tighten set screw (19) to further lock hex bolt (14) in place.

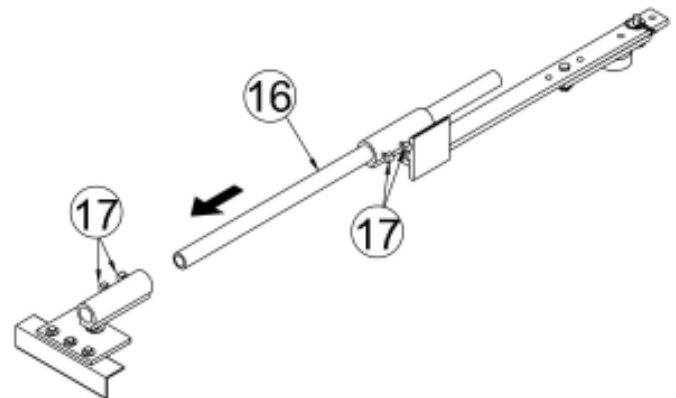

Slide the pipe link (16) through the arm assembly as shown. Place the 5/16" square bolts in the gate clamps (17) and tighten carefully. **Do not overtighten!**

**NOTE:** Illustrations shown on this page are for right-hand application. For left-hand, overtravel stop (9) should be on the opposite side from what is shown above.

# SWG OPERATOR INSTALLATION GUIDE

## VENT PLUG INSTALLATION

Gear reducers used in OSCO gate operators will have solid plugs installed prior to shipment in order to keep the oil inside from spilling out during shipping. A vent plug has been provided to replace this plug during installation. This plug will look similar to the ones shown below. Some models may have a vent plug with a breather pin. This pin should be removed after installing the operator.

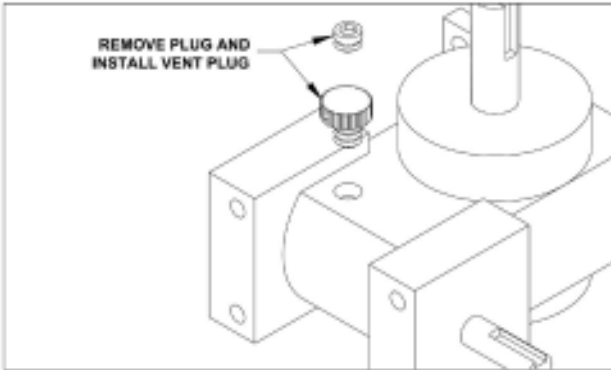

OR

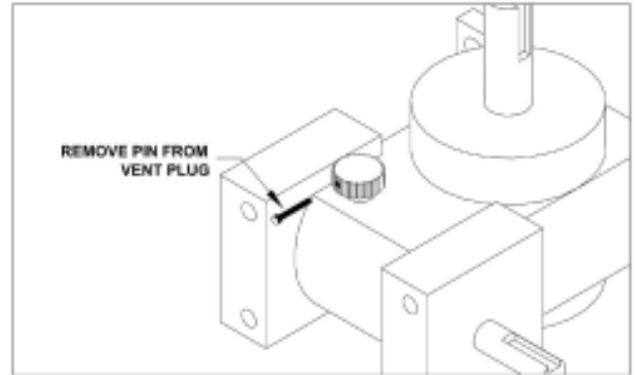

## TORQUE LIMITER ADJUSTMENT

Before adjusting the torque limiter, make sure the gate is in good working condition. One person should be able to move the gate by hand. Be certain the gate moves freely and without binding throughout its travel. Torque limiters are set light at the factory. They must be adjusted during installation, preferably after limit cams have been manually set (see page 9). Adjust the torque limiter tight enough to keep it from slipping during normal operation.

### **To adjust the torque limiter in model SWG:**

1. Bend the locking tabs away from the adjustment nut.
2. *To increase the output*, turn the adjustment nut clockwise one flat, or 1/6 turn, at a time until desired output is obtained.  
*To reduce the output*, turn the adjustment nut counter-clockwise one flat, or 1/6 turn, at a time until desired output is obtained.
3. Bend the locking tabs up to lock the adjustment nut in place.

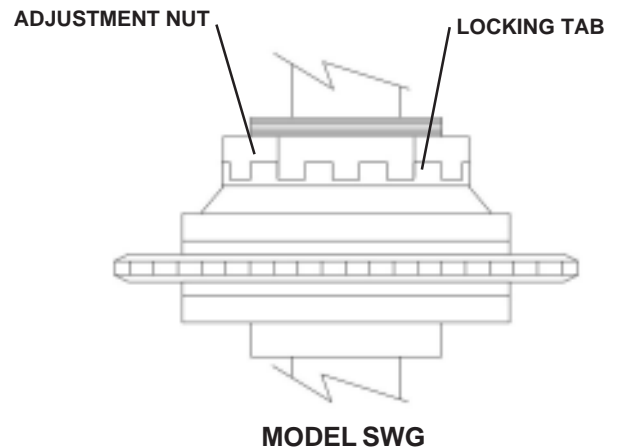

# SWG OPERATOR INSTALLATION GUIDE

## ELECTRICAL CONNECTION AND ADJUSTMENTS



Power supply must be of correct voltage and phase.  
Always disconnect power from operator before servicing.  
Keep clear of gate during operation.

All OSCO gate operators are supplied with a power disconnect switch to turn on and off the power supply available to the operator. Incoming power should be brought into the operator and connected to the labeled pigtails in the disconnect box, following wiring specifications on page 4. A wiring connections print can be found on the inside cover of the operator.

Proper thermal protection is supplied with the operator. The motor contains a thermal overload protector to protect from overheating the motor due to overload or high-frequency operation. This overload will reset automatically after the motor cools down.

## LIMIT CAM ADJUSTMENTS

The limit cams are not preset at the factory and must be adjusted for the length and opening angle of the gate the operator is installed on. The limit switches are activated by a series of rotating limit cams which are attached to the drive shaft. The operator has also been preset in the right hand operation mode. If the installation requires left hand operation a dip switch must be flipped (see page 10).

With the gate connected to the gate operator in a mid-travel position, the power disconnect switch turned **OFF**, and the torque limiter set loose enough to slip freely, manually move the gate to its fully open position.

Once the gate is in the fully open position, adjust the limit cam for open direction. Set the **LSO-1** limit cam so that it has just triggered its switch.

Once the open limit cam is set, repeat the above process for the close direction, **LSC-1**.

After finishing the initial limit cam adjustments, reposition the gate to approximately the center of travel. At this time, adjust the torque limiter as explained on page 8. Turn the power disconnect switch **ON**, stand clear of any moving parts and press the **OPEN** button. Observe the gate as it runs through a complete cycle in both directions, and adjust your limits again if necessary. If the operator stops during travel, you may need to adjust the open or close current sensor adjustment or the maximum run timer (see page 12).

POWER DISCONNECT BOX  
(115VAC VERSION SHOWN)

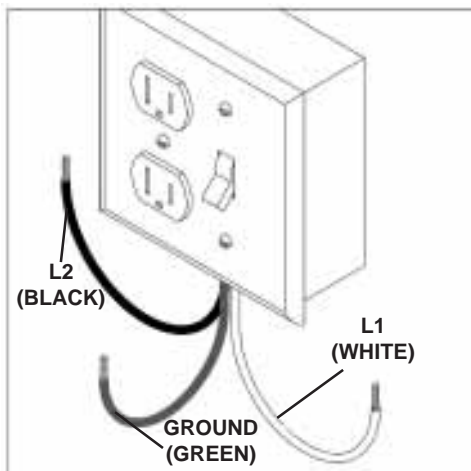

LIMITS and CAMS  
MODEL SWG

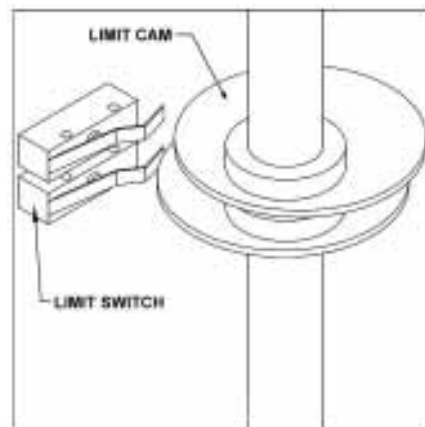

FROM TOP TO BOTTOM:  
**LEFT HAND**    **RIGHT HAND**  
LSC-1        LSO-1  
LSO-1        LSC-1

**WHENEVER HAND OF OPERATION CHANGES, BOTH LIMIT CAMS WILL NEED TO BE ADJUSTED.**

# SWG OPERATOR INSTALLATION GUIDE

## CONTROL BOARD ADJUSTMENTS

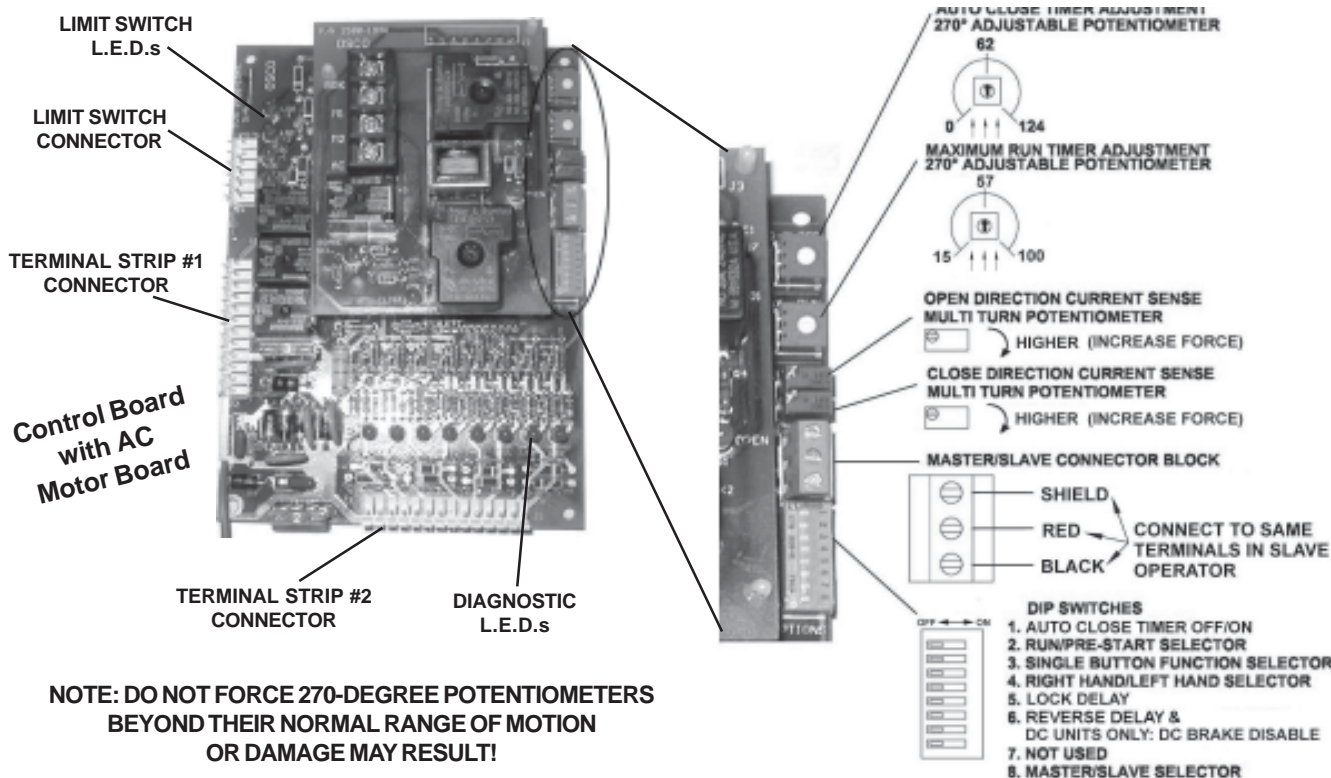

**Auto Close Timer Adjustment:** This 270-degree adjustable potentiometer will signal the operator to close automatically, provided no open, reversing or obstruction signals are present from the fully-open position. This timer is adjustable from 0 to 124 seconds. This feature is turned on or off using dip switch #1.

**Maximum Run Timer Adjustment:** This 270-degree adjustable potentiometer will signal the operator to stop running once it counts down, unless a limit switch is reached or an input is received first. Each time the motor starts, this timer will begin counting. This timer is adjustable from 15 to 100 seconds. If the timer expires, the unit locks out and the emergency alarm sounds.

**Open Direction Current Sense Adjustment:** This multiturn potentiometer is used to calibrate the built-in current sensing feature for detection of obstructions while running in the open direction.

**Close Direction Current Sense Adjustment:** This multiturn potentiometer is used to calibrate the built in current sensing feature for detection of obstructions while running in the closed direction.

**Master/Slave Connection Block:** This terminal block is used in conjunction with two operators to configure two gates to open and close together.

### Dip Switches:

- #1 This switch turns the auto close timer off/on.
- #2 This switch is used in conjunction with alarms and flashing lights that may be added to the operator. When the switch is in the **ON** position, these devices will start approximately two seconds prior to the operator starting. In the **OFF** position, the devices will only work while the operator is running.
- #3 This switch is used in conjunction with single-button controls and radio receivers. In the **ON** position, successive inputs will cause signals in the order of **OPEN-STOP-CLOSE-STOP**. In the **OFF** position, inputs will cause an **OPEN** signal unless the gate is fully open, in which case it will signal **CLOSE**.
- #4 This switch determines right-hand vs. left-hand behavior. When looking from inside the protected area toward the gate, the side of the drive the operator is on determines its hand of operation. In the **OFF** position, the operator is set for right-hand.
- #5 When turned **ON**, this switch will allow a one-second delay for solenoid locks to unlock before the motor starts.
- #6 In the **ON** position, the reverse delay is 1 1/2 seconds. In the **OFF** position, the reverse delay is 3 seconds.
- #7 Not used at this time.
- #8 This switch is used to set Master/Slave configuration. Operators which are stand-alone or master units should be set to **OFF**, while only slave units should have this switch set to **ON**.

# SWG OPERATOR INSTALLATION GUIDE

## TERMINAL CONNECTION DESCRIPTIONS

TERMINALS	FUNCTION	DESCRIPTION OF FUNCTION
24VAC 24VAC N	24VAC	Provides fused 24Volt AC power for accessories. <b>Note: DC models will NOT have 24Volt AC power available.</b>
24VDC+ 24VDC- COMM.	24VDC	Provides fused 24Volt DC power for accessories.
1 & 4	OPEN	Opens the operator. Several accessories such as button stations, keypads, transmitters and card readers can be wired to open.
3 & 4	CLOSE	Closes the operator. Use caution when wiring accessories to these terminals. <b>The gate must be clearly visible from the location of any accessories wired to close.</b>
4 & 5	SINGLE-BUTTON	Performs the single-button function which will alternate between open and close or open, stop and close - depending on dip switch #3. (See page 10 for details.)
2 & 4	STOP	Stops the operator. If no stop button is used, a jumper is required across 2&4.
4 & 6	REVERSE	This function will cause a reversal when the gate is traveling closed and will travel back to the fully open position. Loop detectors are often wired for reverse.
4 & 50	OPEN OBSTRUCTION	This function works only while the operator is opening. Any signal to this function will cause the gate to stop, reverse a short distance, and then stop again. At this time the auto close timer is disabled, and a renewed input will be required to start the gate again. Should the gate be restarted and the signal occur again prior to reaching a limit, the gate will stop again, and this time will sound the emergency alarm and lock out.
4 & 51	CLOSE OBSTRUCTION	This function works exactly like the OPEN OBSTRUCTION, except that it will only work in the closing direction.
4 & 11	SHADOW/HOLD	This function will keep the gate in its fully open position while the signal is present. This is typically used with a loop and loop detector to keep a large swing gate open while vehicular traffic is passing through.
24VDC+ & 60	RUN/PRE-START	A 24Volt DC device such as a strobe light or alarm can be wired to these terminals. Depending on dip switch #2, these devices will either begin three seconds before the operator starts, or only while the motor is running. (See page 10 for details.)

 **You must follow all required safety precautions and instructions at all times. Review the safety brochure included with the operator. If any pages are missing or unreadable, contact OSCO at 1-800-333-1717 to request additional copies.**

 **Never connect a button station within reach of the gate or on the side of the gate operator.**

 **Do not adjust the circuit board current sensing feature too high. It should be adjusted high enough to keep the gate from falsely triggering the sensing, but no higher than necessary for the gate to operate. Do not defeat the purpose of this function!**

# SWG OPERATOR INSTALLATION GUIDE

## CURRENT SENSING ADJUSTMENTS

Because gates vary in construction and may have different force requirements in the open and close directions to move, the OSCO control board has separate Multi-turn potentiometers for adjusting in both directions independently. The adjustment should be set light enough to maintain minimal force (40 lbs.) should an obstruction occur, but high enough to keep the gate moving under normal conditions without interruption.

Prior to adjusting the operator current sensing functions, make sure the gate moves freely in both directions. A badly aligned or poorly maintained gate may cause false triggering of the current sensor. Refer to page **10** when following the instructions below. A factory adjustment tool has been supplied to make these adjustments easier. This tool has been taped to the control box for your convenience.

### CLOSE DIRECTION CURRENT SENSE ADJUSTMENT

When the gate operator leaves the factory, it has been preset for a relatively light gate function and will require additional adjustment. Begin by starting the gate going closed. If the operator stops and reverses, turn the close direction potentiometer (see page **10**) one turn higher, press the **STOP** button, and try again. Repeat this process until the gate no longer causes false tripping of the current sensor. Note that each time the gate operator reverses, the **STOP** button must be pressed. Next, turn the close direction potentiometer lower slowly while the operator is running the gate closed until the gate operator stops and reverses again. From this point, turn the close direction potentiometer higher by 1 1/2 turns for all 115 Volt AC and 24 Volt DC operators, and by 3/4 of a turn higher for all 230 Volt AC operators. Additional fine adjustment by 1/4 turns may be necessary to eliminate false triggering.

### OPEN DIRECTION CURRENT SENSE ADJUSTMENT

Repeat the same process with the open direction potentiometer while running the gate in the open direction. Once this is done, run the gate through several complete cycles and make sure the gate does not false trip in either direction.

Multi-turn Potentiometer

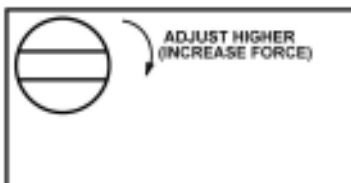

Remember it is important not to set the adjustment too high! Doing so will defeat the purpose of the current sensing as an obstruction detecting feature.

## MAXIMUM RUN TIMER ADJUSTMENT

This adjustable potentiometer sets the maximum length of time the motor will run before shutting down. It should be configured for the time it takes to run the gate fully open or closed, plus an additional 15 seconds. See page **10** for details.

## AUTO CLOSE TIMER ADJUSTMENT

This adjustable potentiometer sets the length of time which elapses before the gate operator automatically closes the gate, from the fully open position, provided no open, reversing, or obstruction signals are present. This feature can be turned on or off via dip switch selection. See page **10** for details. **Do not use the auto close timer without an appropriate reversing device installed!**

## MASTER/SLAVE CONNECTION

A three-wire shielded conductor cable is required to connect master and slave operators. You must use Belden 8760 Twisted Pair Shielded Cable (or equivalent) **only** – OSCO part number 2500-1982, per foot). See page **10** for details of this connection, as well as dip switch selection. Note: The SHIELD wire should be connected in both the master and slave operators. **In addition, you must run power to both the master and slave operators.**

# SWG OPERATOR INSTALLATION GUIDE

---

## ONBOARD L.E.D. INDICATOR DESCRIPTIONS

### Control Board L.E.D. Indicators:

<b>OPEN</b>	This indicator is lit when an open signal is present. This signal can come from such devices as button stations, radio receivers, keypads and telephone entry systems.
<b>CLOSE</b>	This indicator is lit when a closed signal is present. This signal typically comes from three-button stations.
<b>STOP</b>	This indicator is lit when there is a break in the stop circuit. Make sure there is a stop button wired in and working properly.
<b>SINGLE</b>	This indicator is lit when a signal from a single-button station or radio receiver is present.
<b>CLOSE OBST</b>	This indicator is lit when a <b>close obstruction</b> signal is present. This signal can come from edges and photo eyes which have been wired to the close obstruction inputs.
<b>OPEN OBST</b>	This indicator is lit when an <b>open obstruction</b> signal is present. This signal can come from edges and photo eyes which have been wired to the open obstruction inputs.
<b>SAFETY LOOP</b>	This indicator is lit when a reversing signal is present. This signal is generated by a loop detector wired to the safety loop terminals.
<b>SHADOW LOOP</b>	This indicator is lit when a shadow/hold open signal is present. This signal is generated by a loop detector wired to the shadow loop terminals.
<b><u>LH</u>      <u>RH</u></b>	
<b>LSC-1    LSO-1</b>	This indicator is lit when the open #1 limit switch is activated on a right-hand operator, or the close #1 switch on a left-hand. If this indicator is lit and the gate is not in its full open/closed position, the limit may need adjusting or the limit switch may need replacing.
<b>LSC-2    LSO-2</b>	This indicator is lit when the open #2 limit switch is activated on a right-hand operator, or the close #2 switch on a left-hand.
<b>LSO-1    LSC-1</b>	This indicator is lit when the close #1 limit switch is activated on a right-hand operator, or the open #1 on a left-hand. If this indicator is lit and the gate is not in its full open/closed position, the limit may need adjusting or the limit switch may need replacing.
<b>LSO-2    LSC-2</b>	This indicator is lit when the close #2 limit switch is activated on a right-hand operator, or the open #2 switch on a left-hand.

### Motor Board L.E.D. Indicators:

<b>NON LABELED</b>	One of these two indicators will be lit when the motor is running the gate open, and the other is lit when the motor is running the gate closed.
<b>BRAKE REL.</b>	This indicator is lit when the brake is NOT applied.

# SWG OPERATOR INSTALLATION GUIDE

## IMPORTANT NOTES FOR INSTALLATION OF MASTER/SLAVE APPLICATIONS

When setting up Master/Slave gate operators, it is best to make adjustments and run each operator individually. To do this, simply:

- a. Set Dip Switch #4 to proper hand of operation (right-hand or left-hand)
- b. Set Dip Switch #8 as Master (off)

Run each operator making current sensing adjustments as necessary, as indicated on the Control Board Adjustments page of this installation guide. When both operators have been adjusted, turn power off, then turn on Dip Switch #8 in the operator chosen as the Slave.

The timer to close and radio/single button behavior are set in the Master operator.

The following selections are set individually:

- Current Sensing
- Maximum Run Timer
- One-Second Lock Release
- Three-Second Pre-Start Warning
- Right/Left-Hand Selections

## SURGE PROTECTOR INSTRUCTIONS

The optional surge protector should be connected to any inputs that have an accessory connected to it. This includes the 3-button station, so it must be connected to 1, 2A and 3 in all cases. The green wire connected to ground, which is electrically the same as terminal 4. The red wires connect to terminals 2A and 24VDC+. This will cause the 2 amp fuse to blow if this section of the module becomes shorted. With any of the other inputs connected to the surge protector, if their protection line becomes shorted due to a surge over the rating of the module, the corresponding LED on the main board will remain lit, causing a constant signal to the controller. If this is found, please replace the entire surge protector with a new unit.

**Do not simply unhook the shorted wire, as this removes the protection from the circuit that was saved by the protector in the first place!**

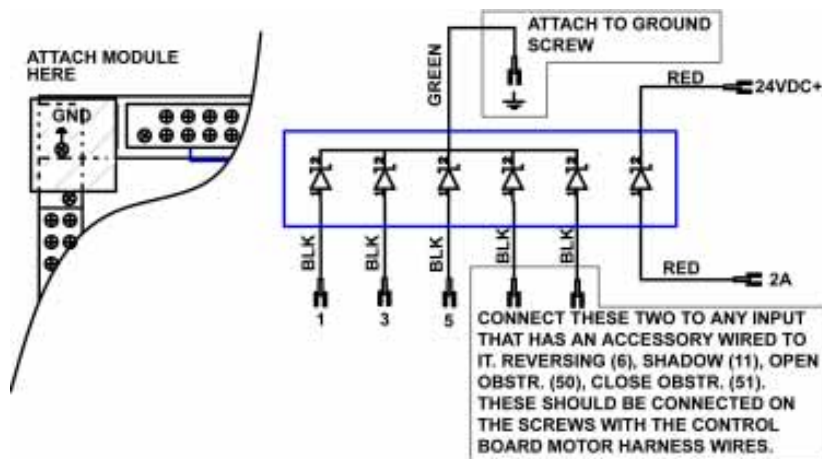

# SWG OPERATOR INSTALLATION GUIDE

## CONTROL and ACCESSORY CONNECTION ILLUSTRATIONS

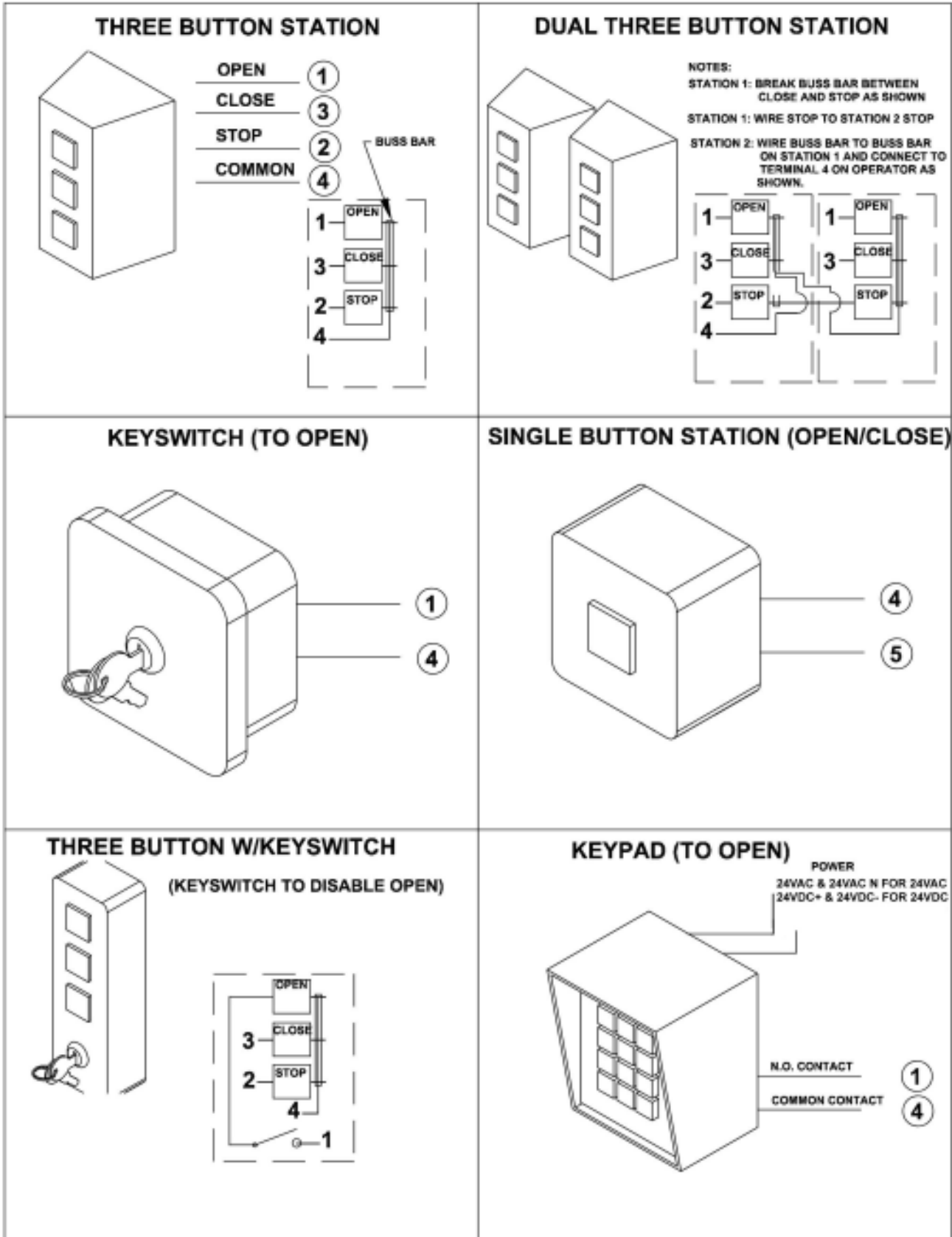

# SWG OPERATOR INSTALLATION GUIDE

## CONTROL and ACCESSORY CONNECTION ILLUSTRATIONS

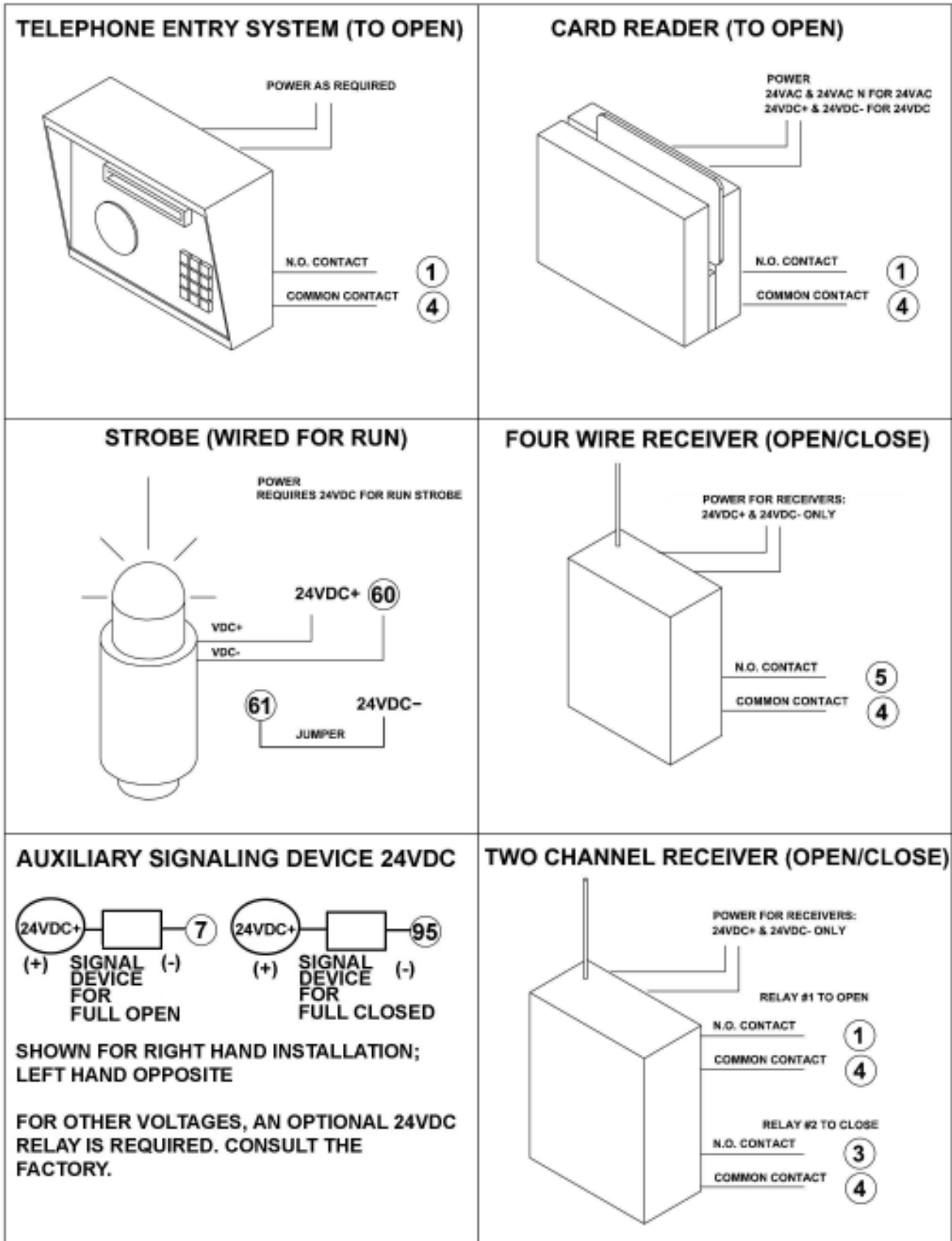

# SWG OPERATOR INSTALLATION GUIDE

## OSCO CONTROL and ACCESSORY CONNECTION ILLUSTRATIONS

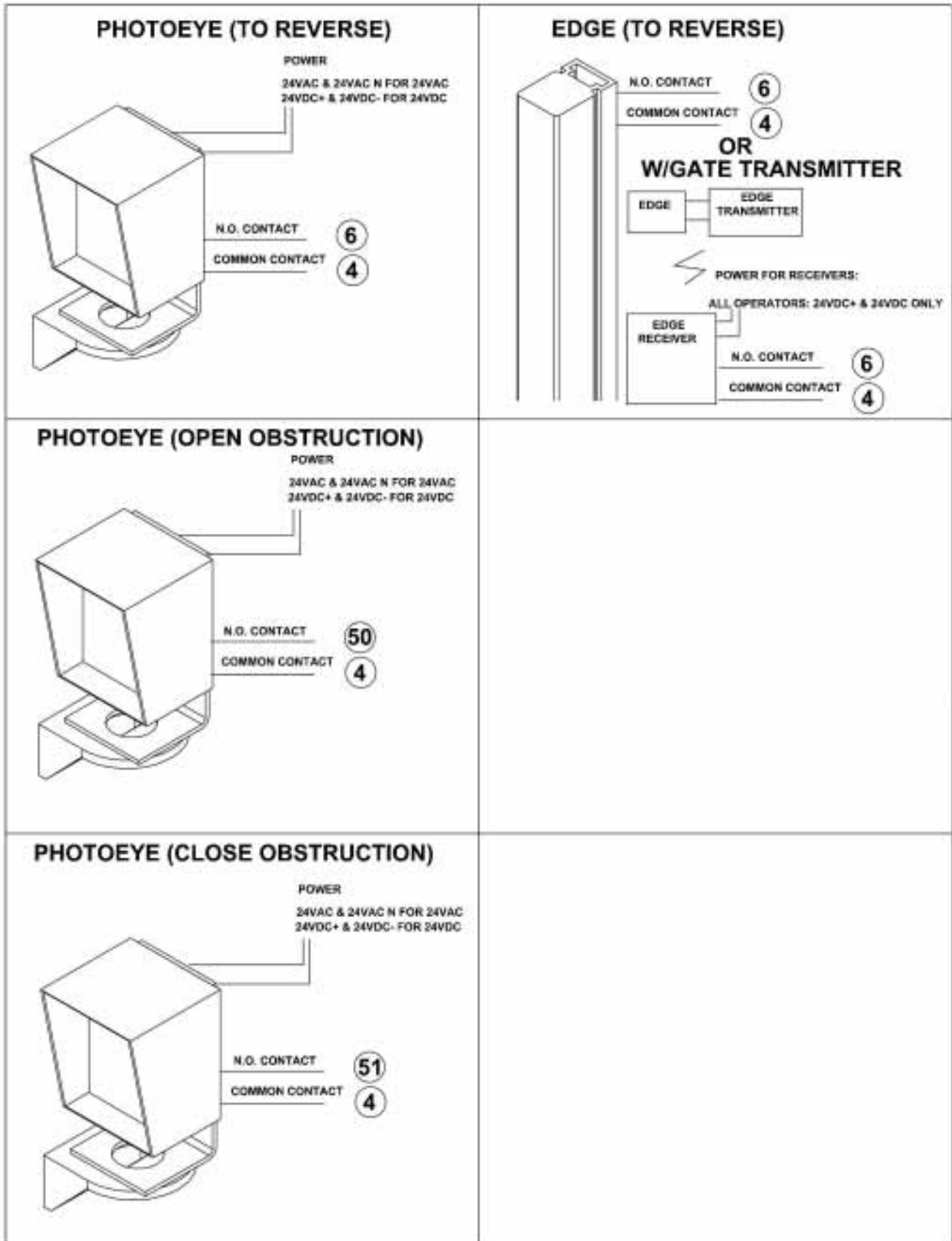



# SWG OPERATOR INSTALLATION GUIDE

## LOOP LAYOUT ILLUSTRATION

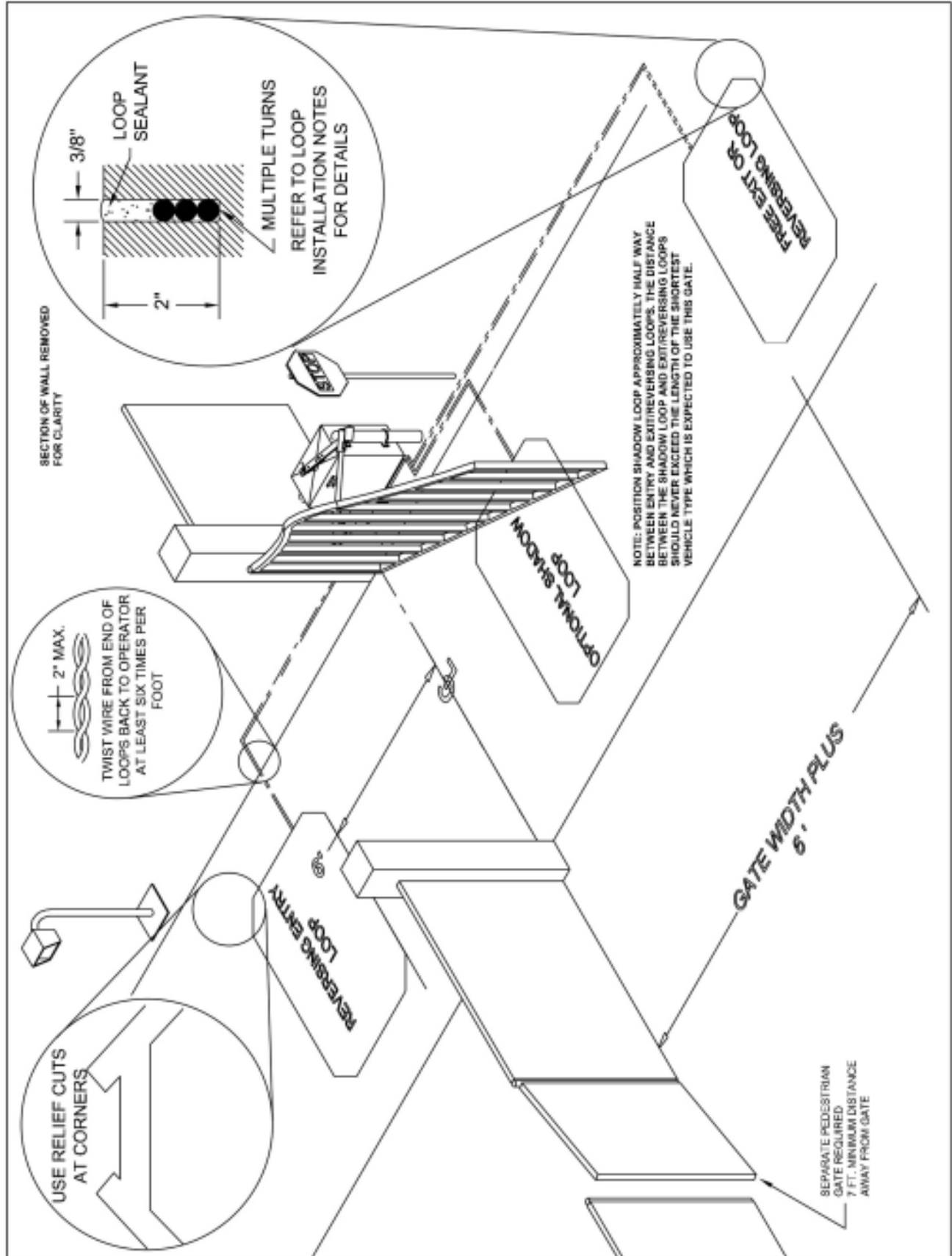

Refer to Connection Descriptions on page 11 and Loop Accessory Connections on page 18 for additional details.

# SWG OPERATOR INSTALLATION GUIDE

## EDGE LAYOUT ILLUSTRATION

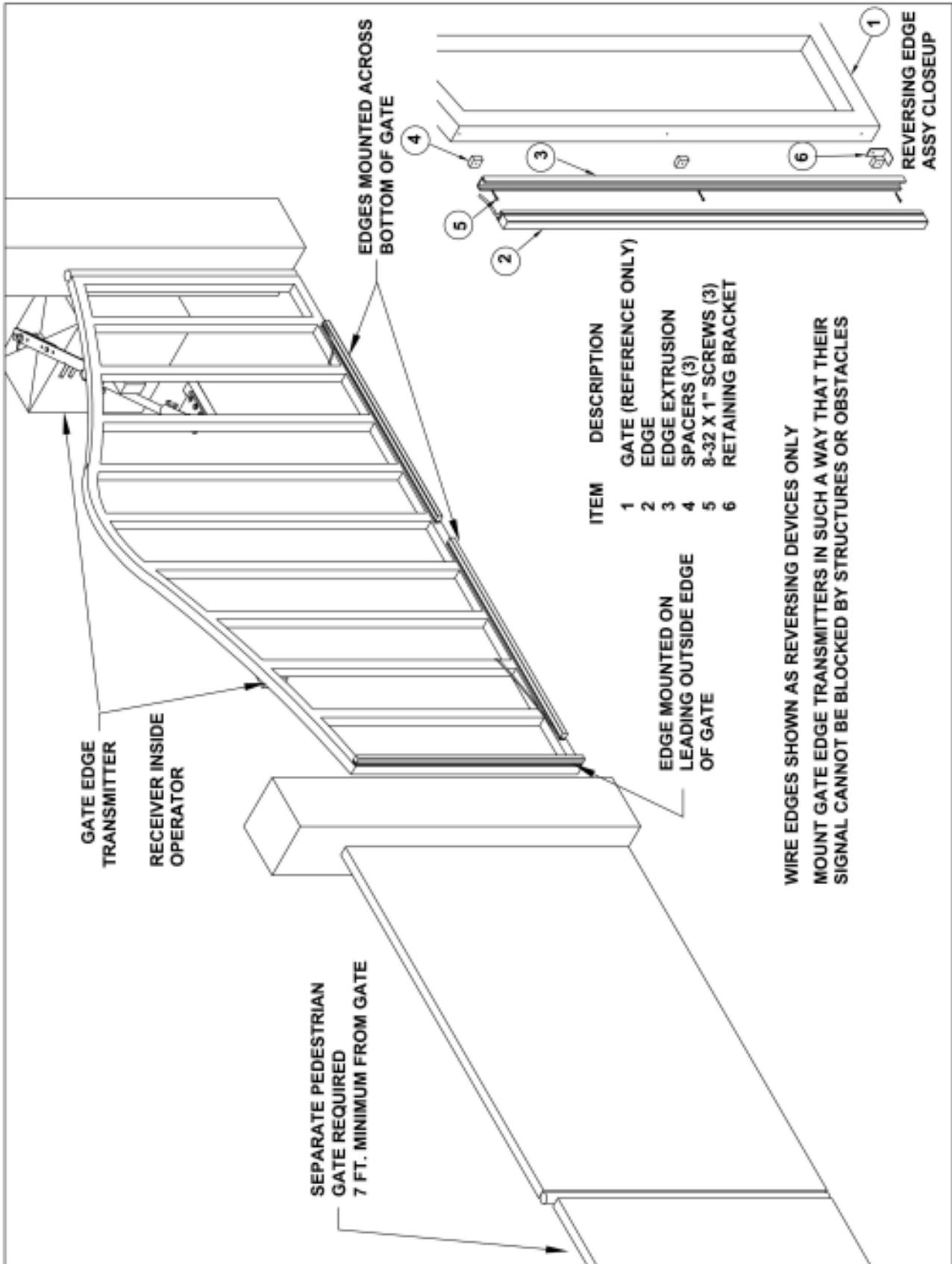

Refer to Connection Descriptions on page 11 and Contact Edge Connections on page 17 for additional details.

# SWG OPERATOR INSTALLATION GUIDE

## PHOTOEYE ILLUSTRATION

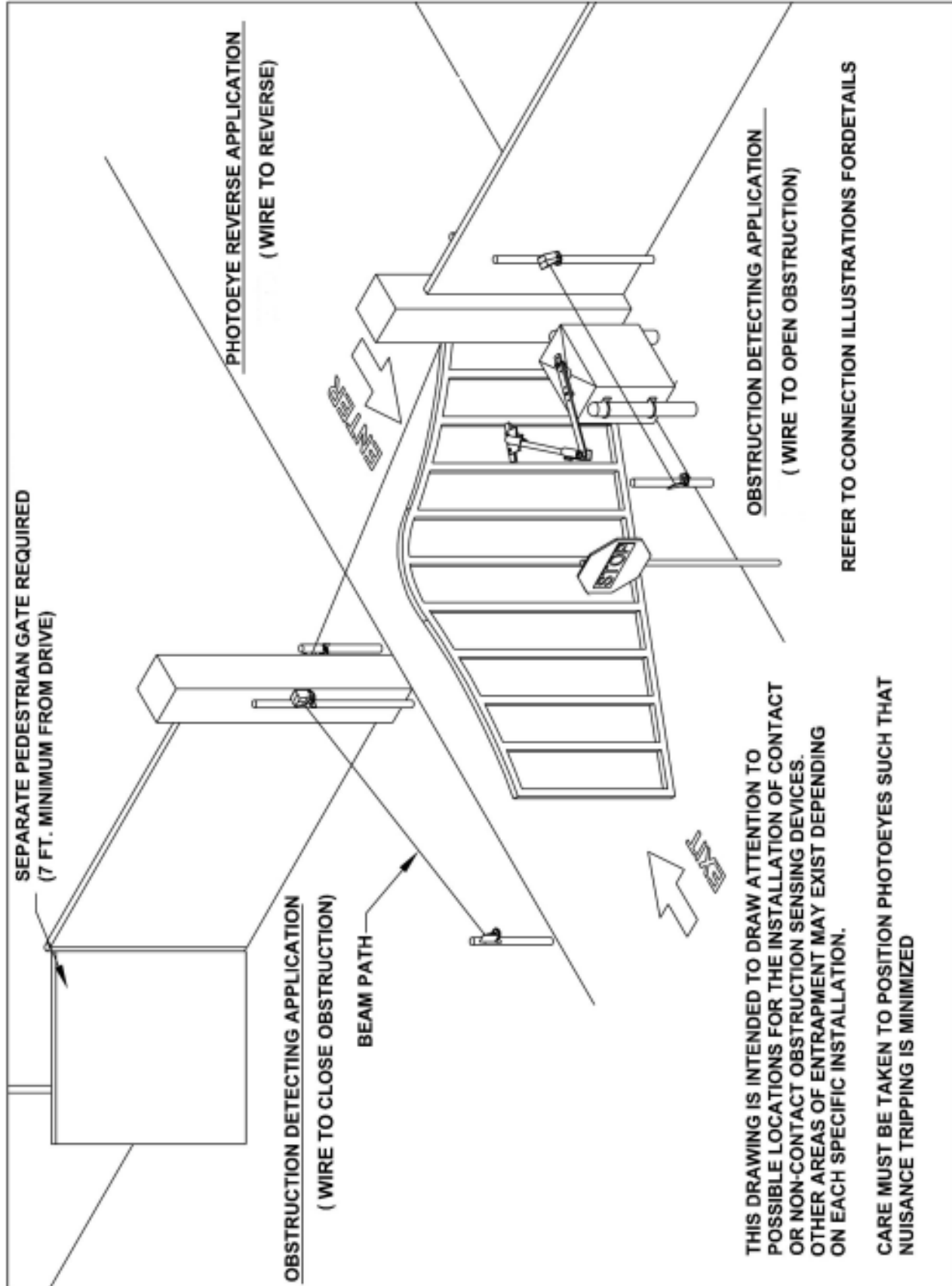

Refer to Connection Descriptions on page 11 and Contact Edge Connections on page 17 for additional details.

# SWG OPERATOR INSTALLATION GUIDE

## TROUBLESHOOTING

### ***Operator fails to start:***

- A. If the operator has been running a large number of cycles, the motor may have gotten hot and tripped the overload. Allow the motor to cool down and the overload will reset automatically.
- B. Make sure you have power at the master distribution panel and that the power has not been turned off.
- C. The secondary fuse on the control board may have blown. Replace the fuse (refer to control box parts list on pages **25** [single phase] or **26** [three phase] for part number information).

### ***Motor operates, but gate does not move:***

- A. In operators with torque limiters and friction pad clutches, check for signs of slipping. You can mark the sprocket and clutch with a yellow or white grease pen and watch for the lines to move apart if slipping is taking place. Adjust the torque limiter tighter if this is the problem.
- B. Check for broken chain or worn belts.
- C. Check all setscrews on pulleys and sprockets and tighten them if necessary, and check for keys which may have fallen loose from keyways.

### ***Motor sounds like it is working harder than normal:***

- A. Make sure the gate is moving freely and without binding throughout its entire travel.
- B. Check the drive chain for obstructions (if the operator has one).
- C. If the operator has an internal brake mechanism, make sure it is releasing.

### ***Limit switch getting out of time:***

- A. Check for proper tension on all limit chains to be sure there is no jumping taking place. Mark one tooth and its corresponding link and run the gate. If the marks have moved, the chain is skipping.
- B. Check the setscrews in limit cams and limit sprockets for tightness. In rotary limit boxes, check the rotary limit nut for sloppiness or stripped threads. Replace if necessary.

### ***Gate stopping part way open or closed (but no visible obstruction):***

- A. The control board may have received a false obstruction input triggered by current sensing set too low. Make sure the gate moves freely through its entire travel before adjusting the current sensing.
- B. The maximum run timer may have counted down and expired. This can be caused by having the timer set too low, if a chain or belt is broken, or if a sprocket or pulley is slipping. When the timer expires, the gate stops and an alarm will sound.
- C. An obstruction signal from an accessory wired to the obstruction input may have triggered falsely. Check the control board for lit L.E.D. indicators for any of the following inputs: safety, shadow, open obstruction, close obstruction, stop, etc. If any are lit when the operator should be running, remove all devices hooked to that function and hook them up one at a time and try to run the operator until the problem device is found. Refer to page **13** for details on the control board indicators.

### ***Gate staying open with automatic system:***

- A. If there are vehicle detectors in your machine which are set up for reverse, one of your loops or loop detectors may be sending a false signal. Disconnect the wire harness and try running the operator.
- B. An opening or reversing device may be stuck or malfunctioning. Try disconnecting these devices and hook them back up one at a time and try running the operator until the malfunctioning device is found.
- C. Make sure the close limit switch isn't activated. If it is, the operator will think the gate is already closed.

## **HOW TO ORDER REPLACEMENT PARTS**

Use the part numbers listed on the following pages. Contact your **local OSCO dealer** or **distributor** to order parts.

1. Supply the model number and serial number of your operator.
2. Specify the quantity of pieces needed and order by part number and name of part.
3. State whether to ship by freight, truck, parcel post, UPS or air express.
4. State whether transportation charges are to be prepaid or collect.
5. Specify name and address of person or company to whom parts are to be shipped.
6. Specify name and address of person or company to whom invoice is to be sent.



# SWG OPERATOR INSTALLATION GUIDE

## MODEL SWG MECHANICAL PARTS LIST

REF. NO.	PART NO.	DESCRIPTION	REF. NO.	PART NO.	DESCRIPTION
	2120-361-BT	Complete Enclosure Assembly with Door	28	2500-764	Limit Switch
1	2110-067-BT	Enclosure Assembly without Door	29	2100-586	Limit Bracket
	2120-362-BT	Enclosure Door and Lock Assembly	30	2510-248	Stop/Reset Button and Bracket Assembly
	2300-716	Stop/Reset Button Cover		2100-1760	Stop/Reset Button Mounting Bracket
2	2110-164	Mounting Plate		2500-1495	Stop/Reset Button
4	2110-163	Bearing Spacer & Bracket Assembly, 3"			
14	2110-173	Bearing Spacer & Bracket Assembly, 2"	31	2100-1782	Mounting Plate (single phase only)
15	2100-1034	Bearing Spacer, 2"	32	2100-1683	Left Mounting Bracket
			33	2100-1773	Right Mounting Bracket with Shelf
17	2100-708	Main Frame Mounting Bracket	34	2510-251-D	Power On/Off Disconnect Assembly with Receptacles (115V Models only)
25	2100-1414	Reducer Spacer Plate		2500-1956	115VAC Duplex Receptacles only
				2500-1957	115VAC Switch only
3	2110-566	Output Shaft Welded Assembly: 1 1/8" bore with 40-B-48 Sprocket		2510-252-D	Power On/Off Disconnect Assembly for 230V Models
	2100-1913-BT	Crank		2500-2205	230VAC Switch only
27	2200-016	Moisture Seal			
26	2100-1344	Moisture Seal Spacer		2500-294	Power On/Off Disconnect Assembly for 3 Phase Operators
19	2200-224	Set Collar, 1 1/8" ID		2500-034	Power Switch only
5	2200-264	Pillow Block Bearing, 1 1/8"			
6	2110-144	Limit Cam			
16	2110-130	Intermediate Shaft Assembly			
	2100-688	Intermediate Shaft			
	2200-279	Sprocket, 40-B-9, 3/4" bore	10	2500-2307	<b>C-Face Motors</b> 1/2 HP, 115V, 1 Phase
13	2200-222	Pillow Block Bearing, 3/4"		2500-2308	1/2 HP, 208/230V, 1 Phase
7	2200-584	Torque Limiter		2500-2309	3/4 HP, 115V, 1 Phase
12	2200-281	Sprocket, 40-A-36		2500-2310	3/4 HP, 208/230V, 1 Phase
35	2400-520	E-Ring, 3/4"		2500-2311	1 HP, 115V, 1 Phase
				2500-2312	1 HP, 208/230V, 1 Phase
11	2200-097	Gear Reducer, 60:1		2500-2313	1/2 HP, 208/230/460V, 3 Phase
9	2200-084	Sprocket, 40-B-13, 1" bore		2500-2314	3/4 HP, 208/230/460V, 3 Phase
	2100-206	#40 Chain, 30 Links		2500-2315	1 HP, 208/230/460V, 3 Phase
	2200-467	#40 Chain, 22 1/2"			
	2200-006	#40 Master Link			
	2400-254	Key, 3/16" x 3/16" x 3"		2500-2336	<b>Capacitors</b> Capacitor for 2500-2307 Motor
	2400-201	Key, 1/4" x 1/4" x 1 1/2"		2500-2337	Capacitor for 2500-2308 Motor
				2500-1926	Capacitor #1 for 2500-2309 Motor
				2500-1930	Capacitor #2 for 2500-2309 Motor
				2500-1931	Capacitor for 2500-2310 Motor
				2500-2338	Capacitor for 2500-2311 Motor
				2500-1932	Capacitor for 2500-2312 Motor

# SWG OPERATOR INSTALLATION GUIDE

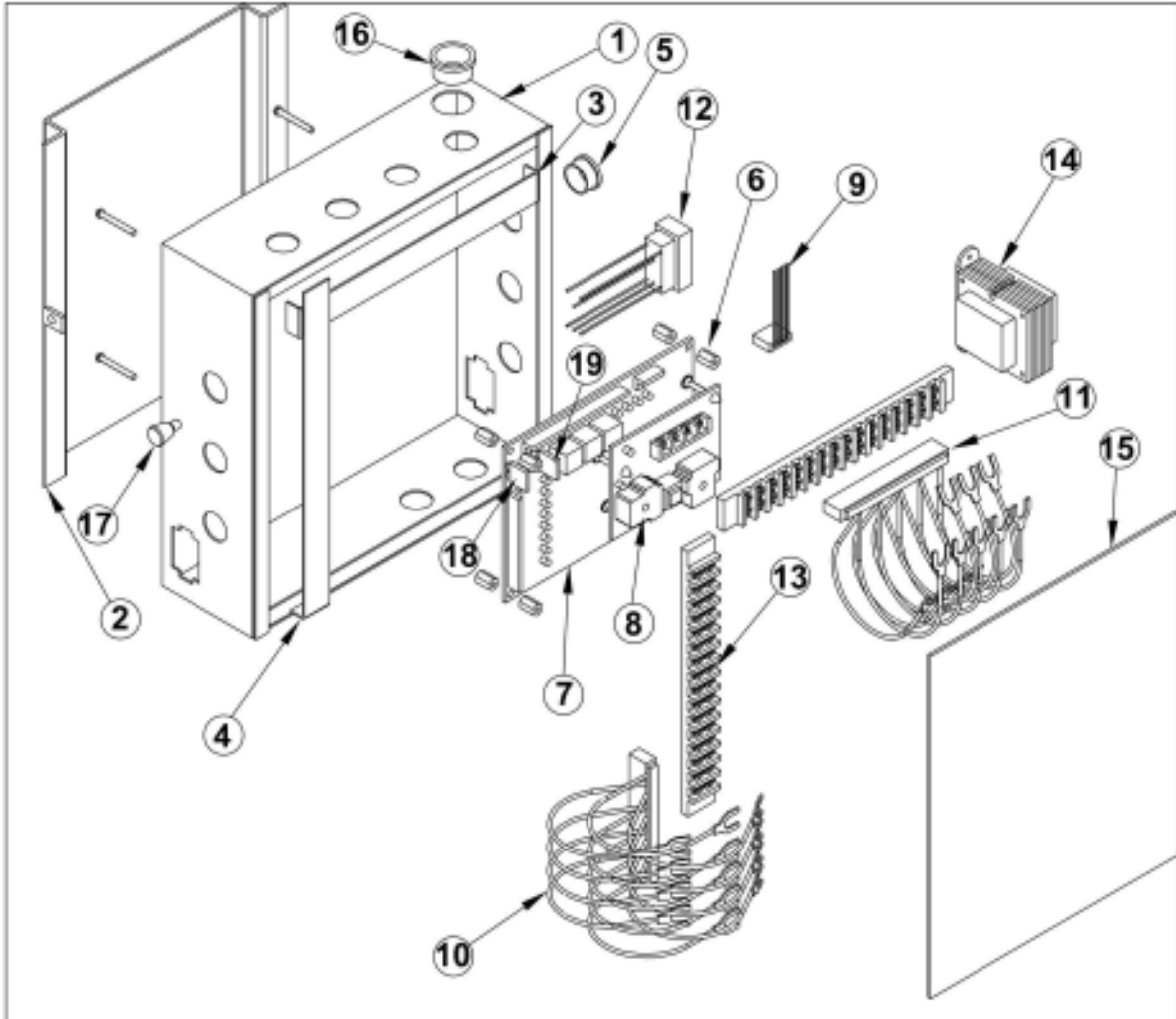

## MODEL **SWG** SINGLE PHASE CONTROL BOX PARTS LIST

REF NO.	PART NO.	DESCRIPTION	REF NO.	PART NO.	DESCRIPTION
1	2100-1778	Control Box Wrapper	15	2300-696	Clear Control Box Cover
2	2100-1757	Control Box Mounting Plate	16	2300-735	Heyco Bushing, 1.09 diameter
3	2100-1762	Terminal Strip Bracket, Output Side	17	2200-876	Plunger, Spring Loaded
4	2100-1761	Terminal Strip Bracket, Input Side		2500-867	Alarm, 24VAC (not shown)
5	2200-122	Heyco Bushing, .87 diameter	18	2500-1966	2 Amp Fuse for Control Board
6	2500-1948	Control Board Standoff	19	2500-1975	3 Amp Fuse for Control Board
7	2510-268	Control Board		2520-391-D	Complete Controller Assembly 115VAC (order limit harness and mounting brackets separately)
8	2500-1946	AC Motor Drive Board		2520-392-D	Complete Controller Assembly 230VAC (order limit harness and mounting brackets separately)
	2510-244	Control Board with AC Motor Board			
9	2510-254	Limit Switch Harness Assembly			
10	2510-249	Input Wire Harness Assembly			
11	2510-250	Output Wire Harness Assembly			
12	2510-261	Control Box Motor Harness Assembly			
13	2500-071	Terminal Strip, 16-141			
14	2500-212	Transformer, 115/24VAC, 40VA			
	2500-791	Transformer, 230/24VAC, 40VA			

# SWG OPERATOR INSTALLATION GUIDE

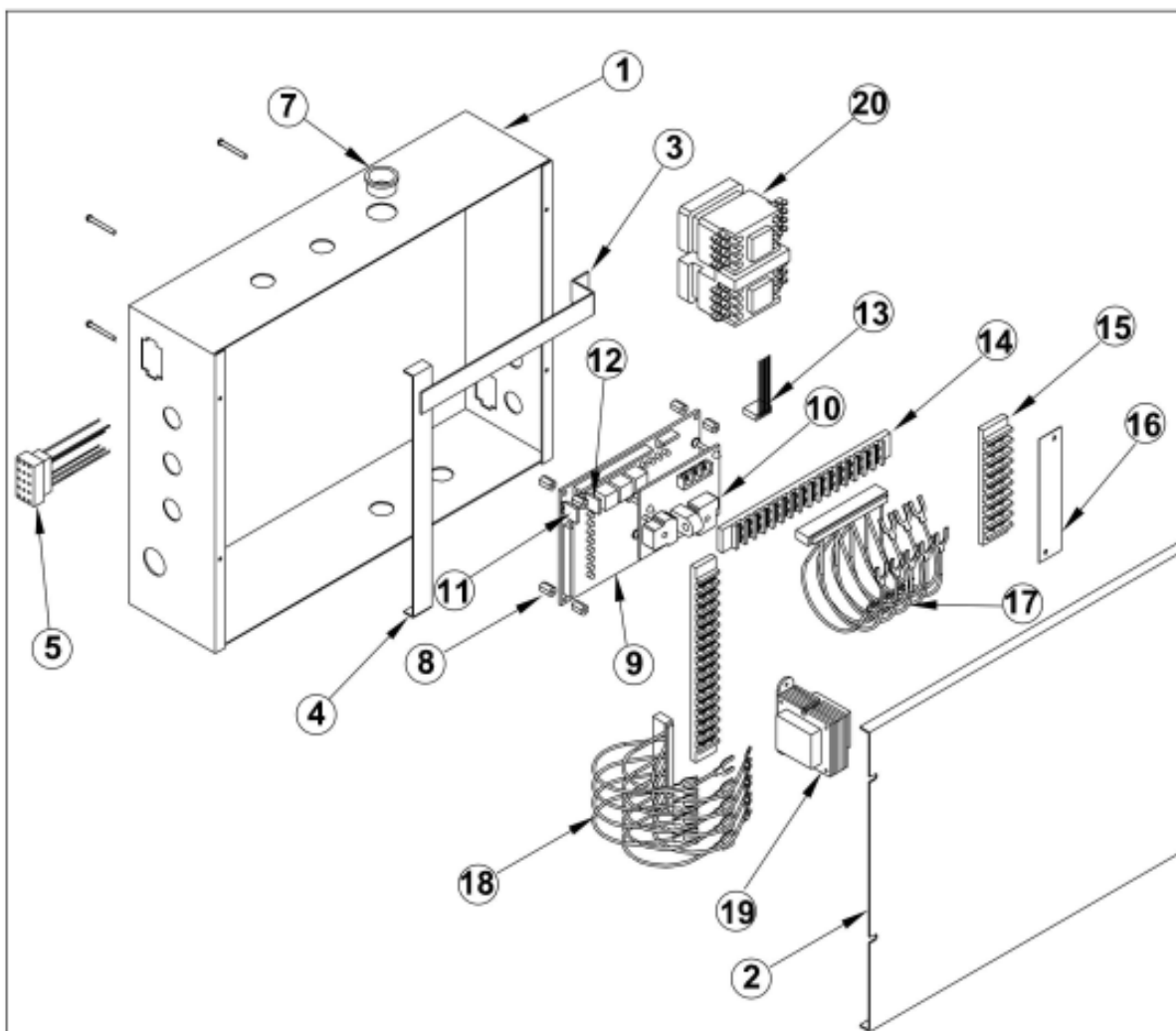

## MODEL **SWG** THREE PHASE CONTROL BOX PARTS LIST

REF NO.	PART NO.	DESCRIPTION	REF NO.	PART NO.	DESCRIPTION
1	2100-1865	Control Box Wrapper	14	2500-071	Terminal Strip, 16-141
2	2100-1866	Control Box Cover	15	2500-270	Terminal Strip, 9-142 <b>OR</b>
3	2100-1864	Terminal Strip Bracket		2500-185	Terminal Strip, 13-142
4	2100-1762	Terminal Strip Bracket	16	2300-488	Terminal Strip Barrier for 9-142 <b>OR</b>
5	2510-293	Control Box Motor Harness Assembly (Leeson motors)		2300-885	Terminal Strip Barrier for 13-142
	2510-355	Control Box Motor Harness Assembly (AO Smith motors)	17	2510-250	Output Wire Harness Assembly
7	2300-735	Heyco Bushing, 1.09 diameter	18	2510-249	Input Wire Harness Assembly
8	2500-1948	Control Board Standoff	19	2500-767	230/24VAC, 75VA, Transformer
9	2510-295	Control Board with 3 Phase Motor Board		2500-768	460/24VAC, 75VA, Transformer
	2510-268	Control Board only	20	2500-2084	24VAC Contactor
10	2500-1980	3 Phase Motor Board		2520-400	Controller, 208/230, 3 Phase
11	2500-1966	2 Amp Fuse for Control Board		2520-401	Controller, 460, 3 Phase
12	2500-1975	3 Amp Fuse for Control Board			(order limit harness and mounting hardware separately)
13	2510-254	Limit Switch Harness			

# SWG OPERATOR INSTALLATION GUIDE

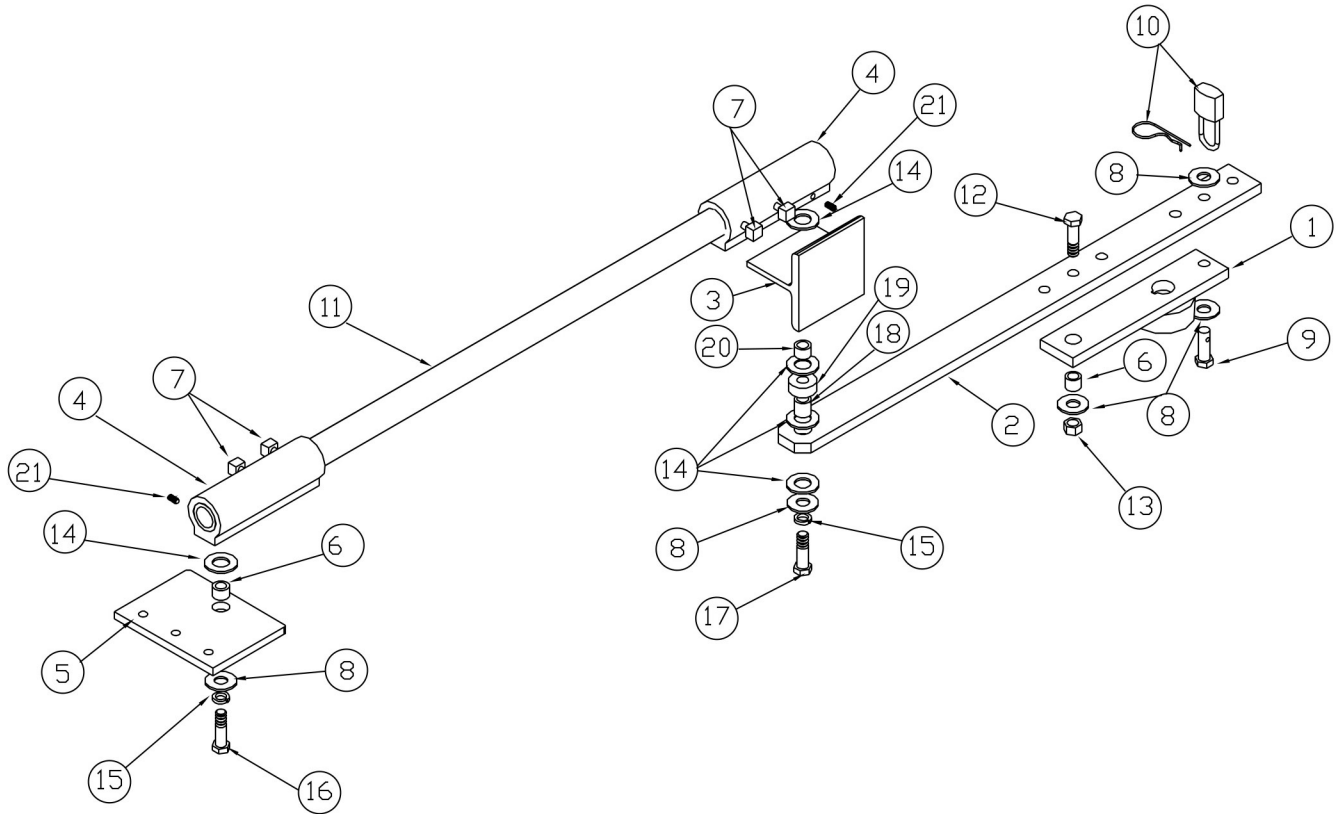

NOTE: CRANK SHOWN FOR REFERENCE ONLY

## MODEL SWG GATE ARM ASSEMBLY PARTS LIST

REF NO.	PART NO.	DESCRIPTION
	2120-449-BT	Complete Arm Assembly
1	2100-1913-BT	Crank (not included in arm assembly)
2	2100-1722-BT	Crank Extension
3	2100-1924-BT	Overtravel Stop
4	2100-1597	Gate Arm Clamp
5	2100-1733-BT	Gate Plate
6	2200-783	Spacer - black, 1/2" ID x 3/4" OD x 9/16" LTB
7	2400-378	Set Bolt, 5/16"-18 x 3/4"
8	2400-376	Flat Washer
9	2100-1547	Disconnect Pin
10	2400-351	Disconnect Hair Pin
	2200-034	Disconnect Lock (optional)
11	2100-122-BT	Pipe Link, 1"
12	2400-380	HHCS, 1/2"-13 x 1 3/4"
13	2400-418	Nylon Lock Nut, 1/2"
14	2300-238	Nylon Washer, 3/4" ID
15	2400-433	Split Lock Washer, 1/2"
16	2400-434	HHCS, 1/2-13 x 1 1/4"
17	2400-482	HHCS, 1/2-13 x 2 1/2"
18	2100-1725	Spacer - yellow, 3/4" OD x 1/2" ID x 3/4" LTB
19	2100-1932-BC	Spacer - black, 1 1/4" OD x 1/2" ID x 1/2" LTB
20	2100-1320	Spacer - zinc-silver, 3/4" OD x 1/2" ID x 1/2" LTB
21	2400-309	Set Screw, 1/4" - 20 x 1

Date Prepared: February 02, 1996  
Supersedes: January 07, 1995  
MSDS Number: 225570

Cette fiche signalétique est aussi disponible en français

## 1. PRODUCT INFORMATION

Product Identifier: ESSO GEAR OIL GX 80W-90  
Application and Use: Premium quality multigrade extreme pressure gear oil for use in automotive applications including some manual transmissions.  
Product Description: A lubricating oil consisting of a saturated and unsaturated hydrocarbons derived from paraffinic distillate, and additives.

## REGULATORY CLASSIFICATION

WHMIS: Not a controlled product  
CEPA: CANADIAN ENVIRONMENTAL PROTECTION ACT  
All components of this product are either on the Domestic Substances List (DSL) or are exempt.

## TRANSPORTATION OF DANGEROUS GOODS INFORMATION

Shipping Name: Petroleum Lubricating Oil  
Class: Not regulated Packing Group: Not regulated  
PIN Number: Not regulated Guide Number: 129  
Please be aware that other regulations may apply.

## TELEPHONE NUMBERS

Emergency 24 hr. 519-339-2145  
Technical Info. 800-268-3183

## MANUFACTURER/SUPPLIER

IMPERIAL OIL  
Products Division  
111 St. Clair Ave. West  
Toronto, Ontario M5W 1K3  
416-968-4111

## 2. REGULATED COMPONENTS

The following components are defined in accordance with subparagraph 13(a) (I) to (IV) or paragraph 14(a) of the Hazardous Products Act:

NAME	%	CAS #
Not applicable		

## 3. TYPICAL PHYSICAL & CHEMICAL PROPERTIES

Physical State: Liquid  
Specific gravity: not available  
Viscosity: 15.50 cSt at 100 deg. C  
Vapour Density: not available  
Boiling point: 229 to 600 deg. C  
Evaporation rate: <0.1 (1=n-butylacetate)  
Solubility in water: negligible  
Freezing/Pour Point: -27 deg. C D97  
Odour Threshold: not available  
Vapour Pressure: <0.1 kPa at 20 deg. C  
Density: 0.89 g/cc at 15 deg. C  
Appearance/odour: Dark brown liquid, petroleum hydrocarbon odour.

## 4. HEALTH HAZARD INFORMATION

NATURE OF HAZARD:  
INHALATION: Negligible hazard at normal temperatures (up to 38 deg. C). Elevated temperatures or mechanical action may form vapours, mists or fumes which may be irritating to the eyes, nose, throat and lungs. Avoid breathing vapours or mists.  
EYE CONTACT: Slightly irritating, but will not injure eye tissue.  
SKIN CONTACT: Low toxicity. Frequent or prolonged contact may irritate the skin.  
INGESTION: Low toxicity.  
ACUTE TOXICITY DATA: Based on animal testing data from similar materials and products, the acute toxicity of this product is expected to be:  
Oral: LD50 > 5000 mg/kg (rat)  
Dermal: LD50 > 3160 mg/kg (rabbit)  
Inhalation: LC50 > 5000 mg/m3 (rat)  
OCCUPATIONAL EXPOSURE LIMIT:  
ACGIH recommends: For oil mists, 5 mg/m3. Local regulated limits may vary.

## 5. FIRST AID MEASURES

INHALATION: Vapour pressure of this material is low and as such inhalation under normal conditions is usually not a problem. If overexposed to oil mist, remove from further exposure. Administer artificial respiration if breathing has stopped. Keep at rest. Call for prompt medical attention.  
EYE CONTACT: Flush eyes with large amounts of water until irritation subsides. If irritation persists, get medical attention.  
SKIN CONTACT: Flush with large amounts of water. Use soap if available. Remove severely contaminated clothing (including shoes) and launder before reuse. If irritation persists, seek medical attention.  
INGESTION: If swallowed, DO NOT induce vomiting. Keep at rest. Get prompt medical attention.

## 6. PREVENTIVE AND CORRECTIVE MEASURES

PERSONAL PROTECTION: The selection of personal protective equipment varies, depending upon conditions of use. In open systems where contact is likely, wear safety goggles, chemical-resistant overalls, and chemically impervious gloves. Where only incidental contact is likely, wear safety glasses with side shields. No other special precautions are necessary provided skin/eye contact is avoided. Where concentrations in air may exceed the occupational exposure limits given in Section 4 and where engineering, work practices or other means of exposure reduction are not adequate, approved respirators may be necessary to prevent overexposure by inhalation.  
ENGINEERING CONTROLS: The use of local exhaust ventilation is recommended to control emissions near the source. Laboratory samples should be handled in a fumehood. Provide mechanical ventilation of confined spaces.  
Esso Sheet 80W-90 082500

HANDLING, STORAGE AND SHIPPING: Keep containers closed. Handle and open containers with care. Store in a cool, well ventilated place away from incompatible materials. Do not handle or store near an open flame, sources of heat, or sources of ignition. Odorous and toxic fumes may form from the decomposition of this product if stored at temperatures in excess of 45 deg. C for extended periods of time or if heat sources in excess of 121 deg. C are used. Empty containers may contain product residue. Do not pressurize cut, heat, or weld empty containers. Do not reuse empty containers without commercial cleaning or reconditioning.

LAND SPILL: Eliminate source of ignition. Keep public away. Prevent additional discharge of material. If possible to do so without hazard. Prevent spills from entering sewers, watercourses or low areas. Contain spilled liquid with sand or earth. Recover by pumping or by using a suitable absorbent. Consult an expert of disposal or recovered material. Ensure disposal in compliance with government requirements and ensure conformity to local disposal regulations. Notify the appropriate authorities immediately. Take all additional action necessary to prevent and remedy the adverse effects of the spill.

WATER SPILL: Remove from surface by skimming or with suitable absorbents. If allowed by local authorities and environmental agencies, sinking and/or suitable dispersants may be used in unconfined waters. Consult an expert on disposal of recovered material. Ensure disposal in compliance with government requirements and ensure conformity to local disposal regulations. Notify the appropriate authorities immediately. Take all additional action necessary to prevent and remedy the adverse effects of the spill.

## 7. FIRE AND EXPLOSION HAZARD

Flashpoint and method: 178 deg. C COC D92  
Autoignition: NA Flammable Limits: LEL: NA UEL: NA

## GENERAL HAZARDS:

Low hazard; liquids may burn upon heating to temperatures at or above the flash point. Decomposes; flammable/toxic gases will form at elevated temperatures (thermal decomposition). Toxic gases will form upon combustion.

FIRE FIGHTING: Use water spray to cool fire exposed surfaces and to protect personnel. Shut off fuel to fire.

Use foam, dry chemical or water spray to extinguish fire. Respiratory and eye protection required for fire fighting personnel. Avoid spraying water directly into storage containers due to danger of boilover. A self-contained breathing apparatus (SCBA) should be used for all indoor fires and any significant outdoor fires. For small outdoor fires, which may easily be extinguished with a portable fire extinguisher, use of an SCBA may not be required.

HAZARDOUS COMBUSTION PRODUCTS: Smoke, carbon monoxide, carbon dioxide and traces of oxides of sulphur. Alkyl mercaptans and sulfides may also be released.

## 8. REACTIVITY DATA

STABILITY: This product is stable. Hazardous polymerization will not occur.  
INCOMPATIBLE MATERIALS AND CONDITIONS TO AVOID: Strong oxidizing agents.  
HAZARDOUS DECOMPOSITION: Smoke, carbon monoxide, carbon dioxide, oxides of sulphur and phosphorus. Alkyl mercaptans and sulfides may also be released.

## 9. NOTES

This MSDS has been revised in Section 3.

## 10. PREPARATION

Date Prepared: February 02, 1996  
Prepared by: Lubricants & Specialties  
IMPERIAL OIL  
Products Division  
111 St. Clair Ave., West  
Toronto, Ontario M5W 1K3  
800-268-3183

CAUTION: "The information contained herein relates only to this product or material and may not be valid when used in combination with any other product or material or in any process. If the product is not to be used for a purpose or under conditions which are normal or reasonably foreseeable, this information cannot be relied upon as complete or applicable. For greater certainty, uses other than those described in Section 1 must be reviewed with the supplier. The information contained herein is based on the information available at the indicated date of preparation. This MSDS is for the use of Imperial Oil. Customers and their employees and agents only. Any further distribution of this MSDS by Imperial Oil customer is prohibited without the written consent of Imperial Oil."

**IMPERIAL OIL**  
Products Division

**ESSO GEAR OIL GX 80W-90**

# SWG OPERATOR INSTALLATION GUIDE

## PREVENTATIVE MAINTENANCE

### IMPORTANT!

- Always disconnect power from operator before servicing.
- Keep clear of gate during operation.

### GENERAL:

OSCO gate operators are designed for many years of trouble-free operation and, under recommended operating conditions, will require only minimal maintenance. To ensure that your unit is ready for operation at all times--and to preclude serious damage or failure--inspect the unit systematically. Proper adjustments and lubrication should be made as recommended.

### LUBRICATION:

**Bearings.** For models which have pillow block style bearings with greaseable fittings, lubricate at least twice a year with a lithium complex based, petroleum oil NLGI 2 rated grease. Oilite and precision sealed bearings do not require additional lubrication.

**Motor.** Motors have sealed ball bearings and do not require further lubrication. If bearing noise develops after several years of operation, bearings should be replaced by a motor repair company, or the motor should be replaced if necessary.

**Drive Chain and Sprocket (slide gate models only).** The main drive chain and sprockets should be inspected for wear, cleaned, and wiped down with a lightly oiled rag every six months.

**Swing Gate Arm (swing gate models only).** Check all bolts for proper tension and tighten if necessary. Make sure the arm folds overextends itself slightly against the overtravel stop to reduce the chance that the gate can be backdriven open. Adjust the close limit slightly if additional travel is required. Lightly lubricate all pivot points with a light machine oil.

**Barrier Gate Arm (barrier gate models only).** Check all bolts for proper tension and tighten if necessary. If the arm has been warped or damaged, replace as necessary.

### ADDITIONAL SIX MONTH PREVENTATIVE MAINTENANCE:

1. For operators which utilize torque limiting clutches, check for proper tightness. If there appears to be dust from wear on the pads, inspect the pads and replace if necessary. If the clutch cannot be adjusted tightly enough to move the gate without slipping, the pads must be replaced.
2. For operators with V-belts, inspect for wear and replace as necessary. Check for proper tension and adjust if required. Check all pulley setscrews for tightness and tighten if necessary.
3. For operators with internal chain drives, inspect chain and sprockets for wear and replace if necessary. Check for proper tension and alignment, and adjust if required. Check all hub sprocket setscrews and tighten if required.
4. Check limit switches and limit actuators (cams, limit nuts, etc.) for wear and replace as required. In rotary limit switch assemblies, wipe the limit shaft clean and apply a light coating of dry lubricant.
5. For operators with magnetic brakes, check for proper adjustment. Brake disc must run free when the brake is engaged. For brake assemblies other than C-face style, the brake should be adjusted so that the solenoid plunger throw is between 3/8" to 1/2". Too much throw will damage the solenoid. **If the solenoid emits a loud buzzing sound when the motor is run, the brake must be adjusted.**
6. In operators which have a disconnect handle, inspect disconnect handle for proper function and lubricate if necessary. Use a lithium based grease on all moving parts.
7. Inspect all nuts and bolts for proper tightness and tighten as necessary.
8. Check all reversing devices for proper function. Inspect all contact edges for wear and replace if required. Check photoeyes for proper alignment and function.
9. Check current sensing for proper adjustment when finished with inspection and maintenance.
10. Inspect the installation area. Are all the warning signs intact and visible? If they are missing or need replaced, contact OSCO. Be sure there are no control stations mounted within reach of the gate. Review safety literature with the customer and advise them to remove any such stations found.

**For slide and swing gate operators, you must inspect the gate for proper operation. The gate should move easily without binding through its entire travel. If the gate does bind, adjust or fix as required. Failure to keep the gate in good working condition will have adverse effects on the operator.**

# SWG OPERATOR INSTALLATION GUIDE

## GATE OPERATOR INSTALLATION CHECKLIST

INSTALLER	CUSTOMER	
_____	_____	1. The gate has been checked to make sure it is level and moves freely in both directions.
_____	_____	2. Potential pinch areas have been guarded so as to be inaccessible <b>OR</b> have contact and/or non-contact obstruction sensing devices installed.
_____	_____	3. The installer has installed one or more contact or non-contact obstruction sensing devices, in compliance with UL325 requirements for this installation.
_____	_____	4. If pedestrian traffic is expected, a separate pedestrian gate has been installed, a minimum of seven feet from the gate. The customer has been informed that <u>all pedestrian traffic must use the pedestrian gate.</u>
_____	_____	5. Warning signs have been installed on each side of the gate in highly visible locations. The customer has been informed that these signs must remain at all times.
_____	_____	6. There are no controls installed on the gate operator, or within seven feet of the gate.
_____	_____	7. The installer has properly adjusted the obstruction sensing feature and has tested the gate to make sure that the gate stops and reverses a short distance with minimal resistance applied (40 lbs. on a swing gate at the end of the gate, 75 lbs. on a slide gate)
_____	_____	8. The installer has instructed the customer in the proper use of the gate operator and reviewed all of the operational functions, obstruction sensing devices, warning beeper and reset, etc.
_____	_____	9. The installer has instructed the customer in the proper use of the operator's manual disconnect feature. The manual disconnect must never be used while the gate is in motion. The power switch must be turned off before using the manual disconnect and disengaging the operator.
_____	_____	10. The installer has reviewed all safety instructions with the customer, and has left the safety instructions and owner's information sheets for their reference.
_____	_____	11. The installer has answered any questions the customer has regarding the operation of the gate operator and gate operator safety precautions.
_____	_____	12. The installer has explained to the customer that a regular maintenance schedule for both the gate and the gate operator is recommended.

By signing this installation checklist, I/we hereby certify that each item listed and checked above has been covered by the installer and is clearly understood by the customer.

\_\_\_\_\_  
Customer Signature

\_\_\_\_\_  
Date

\_\_\_\_\_  
Installer Signature

\_\_\_\_\_  
Date