

# SWR - SWC - SWD

## Swing Gate Operator

### Installation Guide

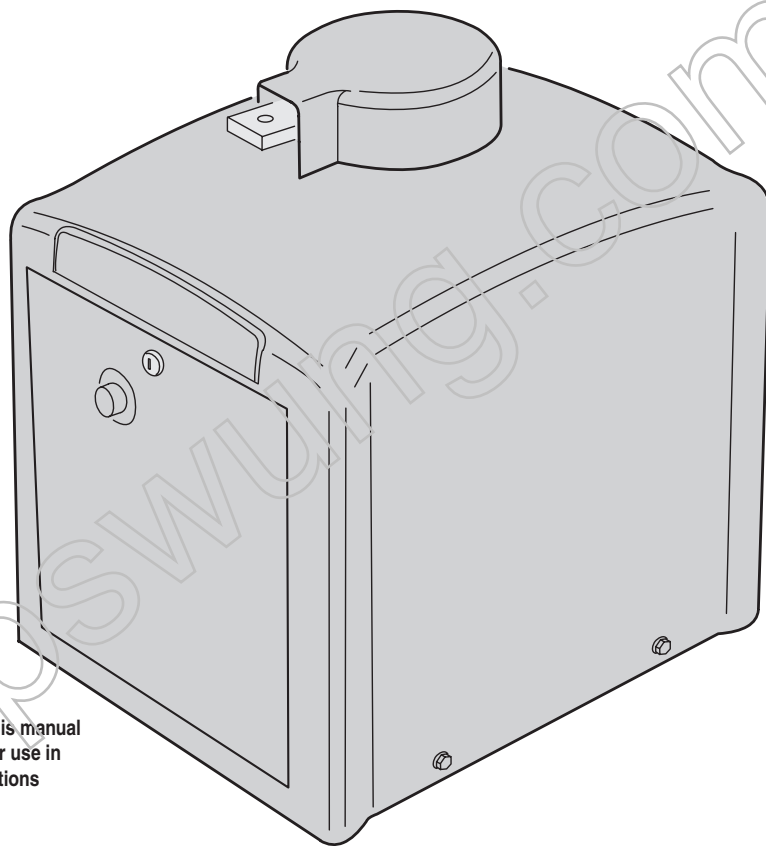

Operator models contained in this manual conform to UL325 standard for use in Class I, II, III, and IV applications

**Linear**<sup>®</sup>  
*Building On Innovation.*

USA & Canada (800) 421-1587 & (800) 392-0123  
(760) 438-7000 - Toll Free FAX (800) 468-1340  
[www.linearcorp.com](http://www.linearcorp.com)

# Table of Contents

<b>Pre-installation Information</b> .....	1	Open Loop	21
Before You Begin.....	1	Reverse Loop	21
Always Check the Gate's Action	1	Shadow/Reset Loop	21
Gate Operator Classifications	1	<b>Operation Indications</b> .....	22
Approved Obstruction Detection Devices	1	Power-up Display	22
<b>Safety Information and Warnings</b> .....	1	Idle Condition	22
Regulatory Warnings.....	1	Last Gate Position/Condition	22
<b>Wiring Specifications</b> .....	2	Pre-start Delay	22
AC Power Wiring	2	Reverse Delay	22
DC Control and Accessory Wiring	2	Run Timer	22
<b>Mounting Pad Installation</b> .....	3	<b>Error Indications</b> .....	22
Mounting Pad Specifications	3	Entrapment	22
<b>Operator Preparation</b> .....	4	COMM LINK Connection Failure	22
Vent Plug Installation	4	MGT Obstacle Transmitter Trouble	22
<b>Gate Arm Installation</b> .....	4	Maximum Run Time Exceeded	22
Setting Left or Right Hand Configuration	4	<b>Troubleshooting</b> .....	23
Gate Plate Installation	4	Contacting Technical Support	23
Choosing Good Harmonics	5	Operator fails to start	23
Installing the Gate Arm on the Operator	5	Motor operates, but gate does not move	23
Setting the Arm Lengths	5	Motor sounds like it is working harder than normal	23
<b>Operator Setup</b> .....	6	Limit switch getting out of time	23
Controller Access	6	Gate stopping part way open or closed (but no visible obstruction)	23
AC Power Connection	6	Gate staying open with automatic system	23
Earth Ground	6	How to Order Replacement Parts	23
Limit Cam Rough Adjustment	7	<b>Model SWR Exploded View</b> .....	24
Torque Limiter Adjustment	7	<b>Model SWC Exploded View</b> .....	25
Limit Cam Fine Adjustment	7	<b>Model SWD Exploded View</b> .....	26
<b>Controller Features</b> .....	8	<b>SWR, SWC, SWD Gate Arm Assembly Exploded View</b> .....	27
<b>Indicator Descriptions</b> .....	9	<b>Model SWD Maintenance</b> .....	28
<b>Terminal Descriptions</b> .....	10	Battery Maintenance	28
<b>Operator Accessory Connections</b> .....	11	DC Motor Brush Replacement	28
<b>Basic Controller Programming</b> .....	12	<b>Preventative Maintenance</b> .....	29
Programming Overview	12	General	29
Entering Programming Mode	12	Lubrication	29
Exiting Programming Mode	12	6-Month Preventative Maintenance	29
Programming Keystrokes	12	<b>FCC Notice</b> .....	29
Left or Right Hand Operation	12	<b>Gate Operator Installation Checklist</b> .....	30
Dual Gate Enable	12		
Auto Close Timer	12		
Run Alarm and Pre-start Alarm	13		
Maximum Open Direction Current Setting	13		
Maximum Close Direction Current Setting	13		
<b>Advanced Controller Programming</b> .....	14		
Entering Advanced Programming Mode	14		
Maximum Run Time	14		
Single Button Input Setup	14		
Stagger Mode	14		
Stagger Delay Time	14		
Auxiliary Relay Mode	15		
Reverse Delay Time	15		
Low Power Mode	15		
Power Failure Mode	15		
Soft Start/Stop Duration	16		
Reset Cycle Count	16		
Maintenance Alert Trigger	16		
Mid-travel Stop Position	16		
Motor Type Selection	16		
Radio Enable	17		
Antenna Installation	17		
Radio Transmitter Learn	17		
Radio Transmitter Delete	17		
MGT Obstacle Transmitter Learn	17		
MGT Obstacle Transmitter Delete	17		
Reset Controller to Factory Defaults	17		
<b>Loop Layout Illustration</b> .....	18		
<b>Safety Edge Layout Illustration</b> .....	19		
<b>Photoeye Installation Illustration</b> .....	20		
<b>Dual Gate Installations</b> .....	21		
<b>Gate Operation</b> .....	21		
Open Button	21		
Close Button	21		
Stop Button	21		
Single Input	21		
Fire Department Input	21		
Open Input	21		
Open Obstruction	21		
Close Obstruction	21		
Reverse Input	21		

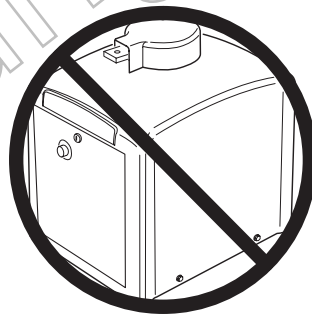



**WARNING**



**ONLY QUALIFIED TECHNICIANS SHOULD WORK ON LINEAR SWING GATE OPERATORS**

---



**WARNING**

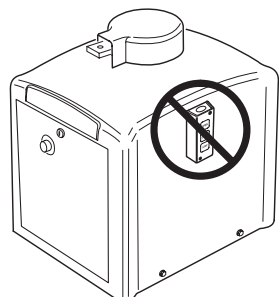
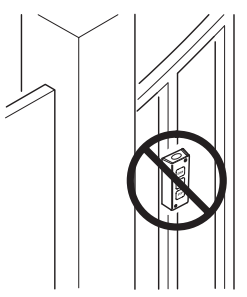

**CONTROLS INTENDED FOR USER ACTIVATION MUST BE LOCATED AT LEAST SIX FEET (6') AWAY FROM ANY MOVING PART OF THE GATE AND WHERE THE USER IS PREVENTED FROM REACHING OVER, UNDER, AROUND OR THROUGH THE GATE TO OPERATE THE CONTROLS. OUTDOOR OR EASILY ACCESSIBLE CONTROLS SHALL HAVE A SECURITY FEATURE TO PREVENT UNAUTHORIZED USE.**

## Pre-installation Information

### Before You Begin...

Before unpacking, inspect the carton for exterior damage. If you find damage, advise the delivery carrier of a potential claim. Inspect your package carefully. You can check your accessory box parts with the enclosed packing slip for your convenience. Claims for shortages will be honored for only 30 days from the date of shipment.

Before installing the operator, read this manual completely to ensure all requirements for proper installation are present. Verify that the voltage to be used matches the voltage of the operator.

If you have any questions about the requirements for proper installation of this gate operator contact technical support at 800-421-1587

### Always Check the Gate's Action

It's very important before installing the gate operator to make sure the gate's swing is free and level throughout the entire swing path. If the gate does not seem to operate properly, it may affect the operator performance or greatly shorten the life of the unit. The gate should also be designed so that airflow is ample to prevent wind resistance and drag.

### Gate Operator Classifications

All gate operators can be divided into one of four different classifications, depending on their design and usage. Install this gate operator only when the operator is appropriate for the construction and usage class as defined below:

- **Class I Residential Vehicular Gate Operator**  
A vehicular gate operator intended for use in a home or for one to four single family dwellings with a common garage or parking area associated with these dwellings.
- **Class II Commercial / General Access Vehicular Gate Operator**  
A vehicular gate operator intended for use in a commercial location or building such as a multi-family housing unit of five or more single family units, hotel, retail store or other building servicing the general public.
- **Class III Industrial / Limited Access Vehicular Gate Operator**  
A vehicular gate operator intended for use in an industrial location or building such as a factory or loading dock area or other location not intended to service the general public.
- **Class IV Restricted Access Vehicular Gate Operator**  
A vehicular gate operator intended for use in a guarded industrial location or building such as an airport security area or other restricted access locations not servicing the general public, in which unauthorized access is prevented via supervision by security personnel.

### Approved Obstruction Detection Devices

The following contact or non-contact obstruction detection devices have been approved for use with this swing gate operator as part of a UL325 compliant installation:

- **Contact Edges**  
Miller Edge Models MGO20, MGR20, MGS20, ME120
- **Photoeyes**  
MMTC Model IR-55 (165' range - P/N 2520-441)  
MMTC Model E3K (28' range - P/N 2520-031)

## Safety Information and Warnings

THE FOLLOWING FORMATS ARE USED FOR SAFETY NOTES IN THESE INSTRUCTIONS.



### Regulatory Warnings

Read the following before beginning to install this swing gate operator:

**IMPORTANT INSTALLATION SAFETY INSTRUCTIONS**

**WARNING**

**TO REDUCE THE RISK OF SEVERE INJURY OR DEATH TO PERSONS, REVIEW THESE INSTALLATION SAFETY STEPS BEFORE PROCEEDING**

1. READ AND FOLLOW ALL INSTALLATION INSTRUCTIONS.
2. Read the yellow "Safety Instructions" brochure enclosed with the packet of information. If any pages are missing or are unreadable, or you do not have the safety instructions, please call Linear at 1-800-421-1587 to request additional copies.
3. ALL ELECTRICAL CONNECTIONS TO THE POWER SUPPLY MUST BE MADE BY A LICENSED ELECTRICIAN AND MUST OBSERVE ALL NATIONAL AND LOCAL ELECTRICAL CODES.
4. A separate power-disconnect switch should be located near the operator so that primary power can be turned off when necessary.
5. Install the enclosed warning signs on both sides of the gate. A minimum of two (2) WARNING SIGNS shall be installed, one on each side of the gate where easily visible.
6. Never reach between, through or around the fence to operate the gate.
7. Never connect a button station within reach of the gate or on the side of the gate operator.
8. Do not adjust the operator controller's current sensing feature too high. It should be adjusted high enough to keep the gate from falsely triggering the sensing, but no higher than necessary for the gate to operate. **DO NOT DEFEAT THE PURPOSE OF THIS FUNCTION!**
9. You must install all required safety equipment.
10. UL325 Compliance requires the use of contact edges or photoelectric controls on all automatic or remotely-controlled gate operators.
11. The operator is intended for installation only on gates used for vehicles. Pedestrians must be supplied with a separate access opening. The pedestrian access opening shall be designed to promote pedestrian usage. Locate the gate such that persons will not come into contact with the vehicular gate during the entire path of travel of the vehicular gate.

## Wiring Specifications

Refer to the following steps for details on power and accessory wiring for the operator.



**WARNING**



**ALL AC ELECTRICAL CONNECTIONS TO THE POWER SOURCE AND THE OPERATOR MUST BE MADE BY A LICENSED ELECTRICIAN AND MUST OBSERVE ALL NATIONAL AND LOCAL ELECTRICAL CODES.**

### USE COPPER WIRE ONLY!

#### AC Power Wiring

- Find the listing on this page corresponding to the model, voltage and horsepower rating of your operator.
- The distance shown in the table is measured in feet from the operator to the power source. **DO NOT EXCEED THE MAXIMUM DISTANCE.** These calculations have been based on standard 115 V and 230 V supplies with a 10% drop allowable. If your supply is under the standard rating, the runs listed may be longer than what your application will handle, and you should not run wire too near the maximum distance for the gauge of wire you are using.
- When large-gauge wire is used, a separate junction box (not supplied) may be needed for the operator power connection.
- Wire length calculations are based on the National Electrical Code, Article 430 and have been carefully determined based on motor inrush, brake solenoids, and operator requirements.
- Connect power in accordance with local codes. **The green ground wire must be properly connected.**
- Wire insulation must be suitable to the application.
- Electrical outlets are supplied in all 115 VAC models for convenience with occasional use or low power consumption devices only. If you choose to run dedicated equipment from these devices, it will decrease the distance for maximum length and the charts will no longer be accurate.

#### DC Control and Accessory Wiring

- All control devices are now 24 VDC, which can be run up to 2000 feet with 14 AWG wire.**
- Control wiring must be run in a separate conduit from power wiring. Running them together may cause interference and faulty signals in some accessories.
- A three-wire shielded conductor cable is required to connect two operators together for dual operation. You must use Belden 8760 Twisted Pair Shielded Cable (or equivalent) only – P/N 2500-1982, per foot). See Page 21 for details of this connection. **Note: The shield wire should be connected in both the operators.**

MODEL SWR POWER WIRING			
VOLTS & HP	MAXIMUM DISTANCE (FEET)		WIRE GAUGE
	SINGLE	DUAL	
115 VOLTS 1/2-HP	316	158	12
	502	251	10
	800	400	8
	1272	636	6
	2022	1011	4
230 VOLTS 1/2-HP	764	382	12
	1218	609	10
	1936	968	8
	3076	1538	6
	4896	2448	4

MODEL SWC POWER WIRING			
VOLTS & HP	MAXIMUM DISTANCE (FEET)		WIRE GAUGE
	SINGLE	DUAL	
115 VOLTS 1/2-HP	222	111	12
	354	177	10
	566	283	8
	900	450	6
	1430	715	4
115 VOLTS 3/4-HP	178	89	12
	282	141	10
	450	225	8
	716	358	6
	1140	570	4
115 VOLTS 1-HP	160	80	12
	254	127	10
	406	203	8
	646	323	6
	1026	513	4
208 VOLTS 1/2-HP	760	380	12
	1200	600	10
	1924	962	8
	3060	1830	6
	4864	2432	4
208 VOLTS 3/4-HP	604	302	12
	958	478	10
	1526	763	8
	2424	1212	6
	3856	1928	4
208 VOLTS 1-HP	544	272	12
	864	432	10
	1374	686	8
	2184	1092	6
	3476	1738	4
230 VOLTS 1/2-HP	894	447	12
	1422	711	10
	2264	1132	8
	3600	1800	6
	5724	2862	4
230 VOLTS 3/4-HP	710	355	12
	1128	564	10
	1796	898	8
	2852	1426	6
	4538	2269	4
230 VOLTS 1-HP	640	320	12
	1016	508	10
	1616	808	8
	2570	1285	6
	4090	2045	4

MODEL SWD POWER WIRING			
VOLTS & HP	MAXIMUM DISTANCE (FEET)		WIRE GAUGE
	SINGLE	DUAL	
115 VOLTS 1/2-HP	970	485	12
	1542	771	10
	2452	1226	8
	3898	1949	6
	6200	3100	4

## Mounting Pad Installation

The gate operator mounts bolted to a custom poured concrete mounting pad. The pad supports the operator and prevents it from twisting during operation.

An optional post mount kit is also available (P/N 2120-483) which allows installation without a concrete mounting pad.

## Mounting Pad Specifications

Recommended pad size is 24" x 20" x 18" deep minimum. Pad depth should be set according to local codes and at least as deep as frost line.

If soil conditions may cause the operator and pad to shift or twist during operation, anti-rotation legs may be required. Use two 6" diameter, 10" deep legs to counteract this problem as shown.

5/8" J-bolts may be set into the concrete before it sets following the dimensions shown, or drilled after the concrete sets.

**⚠ WARNING ⚠**  
**The operator is intended for installation only on gates used for vehicles. Pedestrians must be supplied with a separate access opening. The pedestrian access opening shall be designed to promote pedestrian usage. Locate the gate such that persons will not come into contact with the vehicular gate during the entire path of travel of the vehicular gate.**

**⚠ WARNING ⚠**  
**The gate must be installed in a location so that enough clearance is supplied between the gate and adjacent structures when opening and closing to reduce the risk of entrapment. Swing gates shall not open into public areas.**

✓ **NOTE:** Maximum gate opening angle is approximately 95 degrees, depending on gate width. If larger opening angle is required, non-standard positioning of the operator and modified articulating arms may be required. Contact the factory for technical information, pricing, and availability.

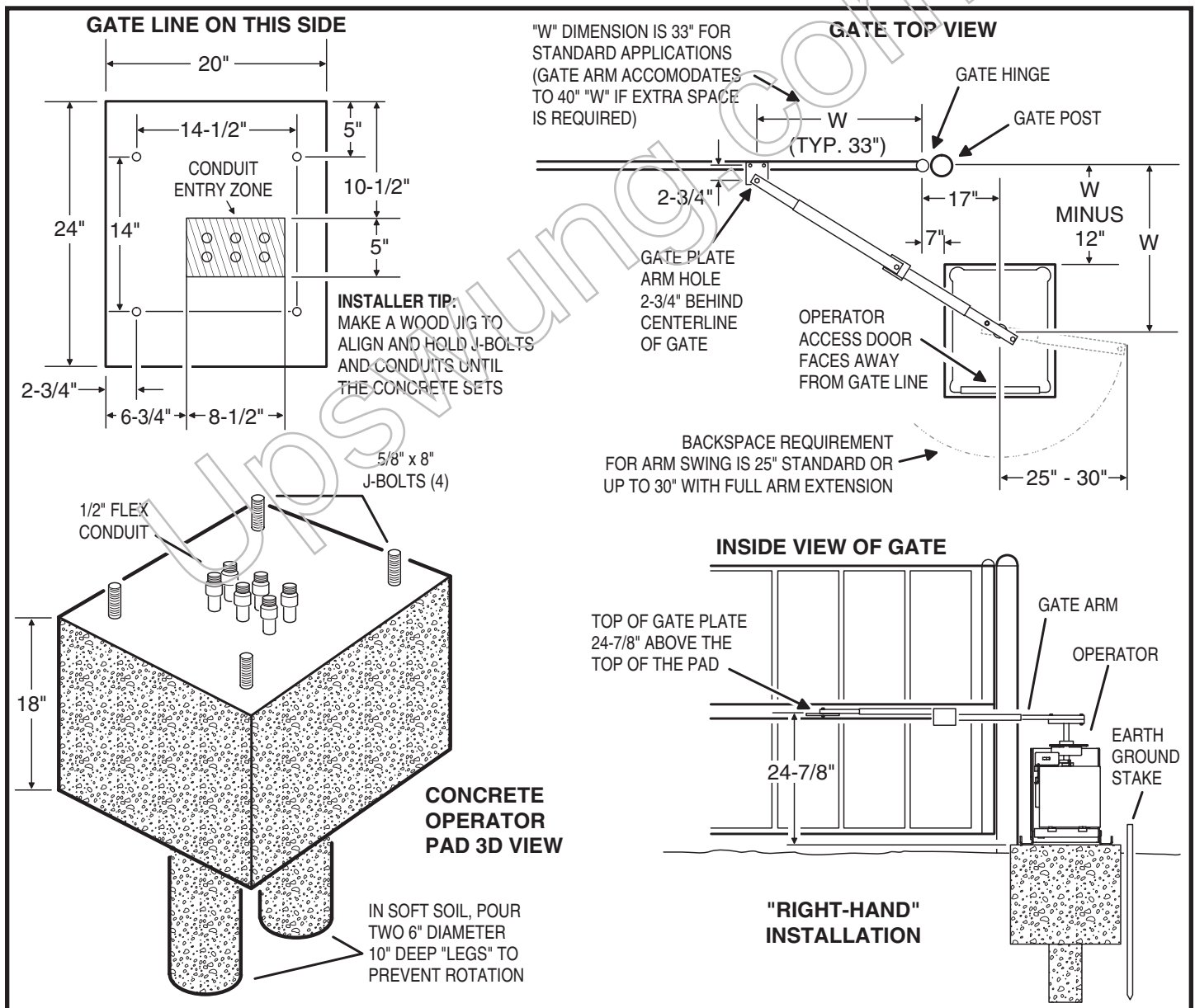

Figure 1. Mounting Pad Specifications

## Operator Preparation

### Vent Plug Installation

In order to keep gear oil from spilling out during shipping, gear reducers used in gate operators have either a solid plug, or a sealed vent plug, installed at the factory.

For operators with a solid plug, replace the solid plug with the vent plug provided (see Figure 2).

With the vent plug installed, remove the vent plug's breather pin to allow the gear box to vent (see Figure 2).

### Gate Arm Installation

The gate arm connects the operator to the gate. The arm supplied can be used in left-hand or right-hand installations. After the proper length of the crank extension and link section of the arm has been determined, the arm is welded to complete the assembly.

### Setting Left or Right Hand Configuration

The welded style gate arm has been pre-assembled at the factory in right-hand configuration (the back of the overtravel stop faces toward the drive when the gate is fully closed and the arm is installed). For a left-hand operator, rotate the upper portion of the arm as shown in Figure 3 to convert the arm into a left-hand orientation.

### Gate Plate Installation

The gate plate mounts on the gate at the recommended height (24-7/8" above the top of the operator pad). The gate plate supplied with the arm assembly can be welded to the gate as shown in Figure 4. Holes have been provided for securing the gate plate to an aluminum gate.

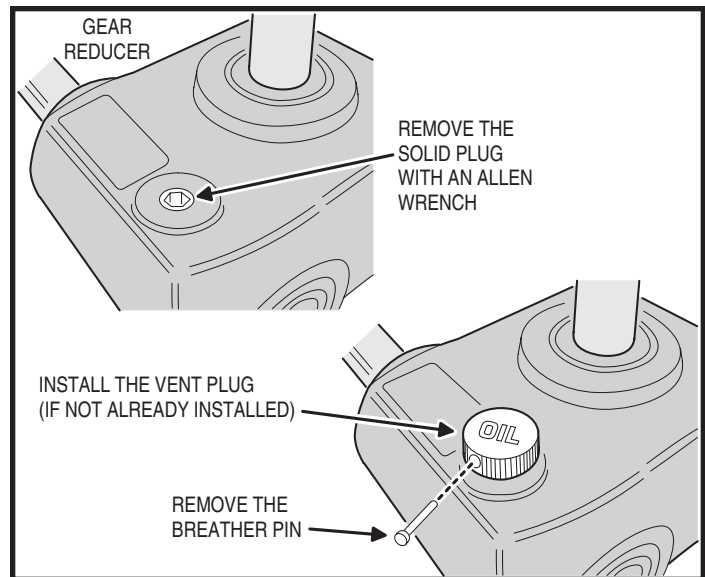

Figure 2. Vent Plug Installation

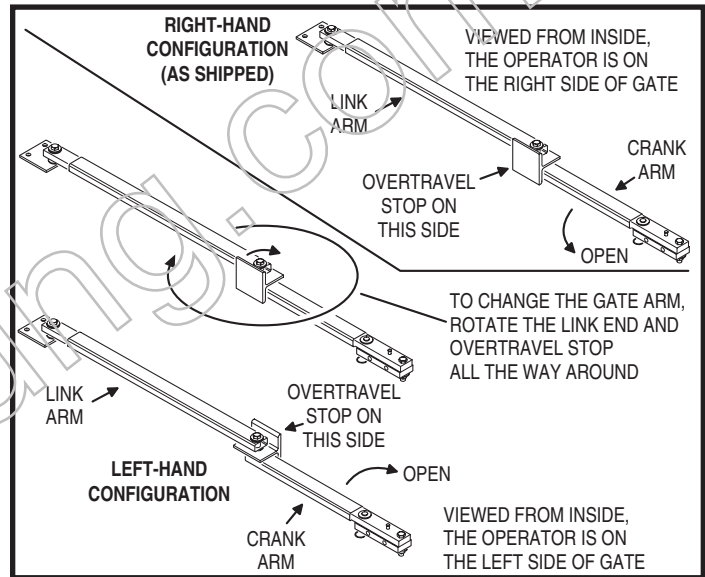

Figure 3. Left or Right Hand Gate Arm Setup

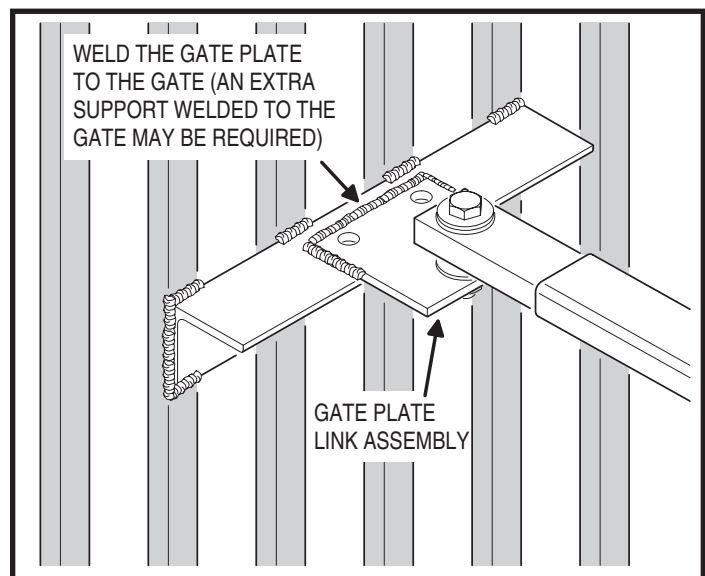

Figure 4. Gate Plate Installation

## Gate Arm Installation (Cont.)

### Choosing Good Harmonics

Good harmonics are necessary to minimize wear and tear on the operator. The gate will have smoother starts and stops when the arm is installed with good harmonics. Figure 5 shows an example of good and bad arm harmonics.

### Installing the Gate Arm on the Operator

The hex cap screws (see Figure 6) in the side of the crank assembly are shipped loose for placement on the operator drive shaft. Once in place, tighten these cap screws in place by applying 75 ft-lbs of torque. If it becomes necessary to remove the crank, you can do so by loosening these bolts. The arm can also be disconnected for manual operation of the gate by removing the disconnect pin.

### Setting the Arm Lengths

Most installations will use the standard dimensions specified. The dimensions shown in Figure 7 can be used to adjust and set the arm. If non-standard mounting is required, contact the factory for information.

Once the arm lengths have been determined, use clamps to temporarily attach the solid bars to their sections of rectangular tubing. If clamps are unavailable, you may also tack weld the parts in place. **It is recommended that you check the arm for proper action and full gate travel before fully welding the parts together. REMOVE THE GATE ARM BEFORE WELDING!** Apply Krylon® metallic gold spray paint or equivalent to touch up welds when finished.

**CAUTION**  
DO NOT WELD THE GATE ARM WHILE IT IS ATTACHED TO THE OPERATOR! Connecting the welder's ground to the operator's frame will cause the arc welding current to pass through the operator parts, severely damaging or destroying the operator.

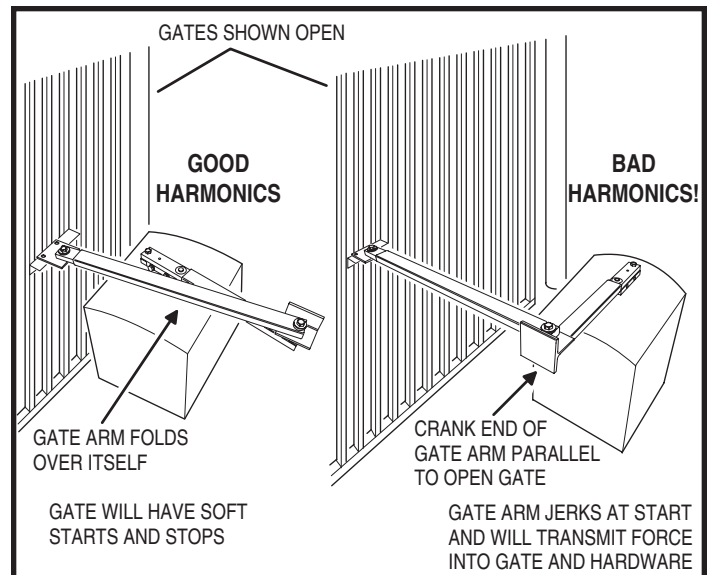

Figure 5. Gate Arm Harmonics

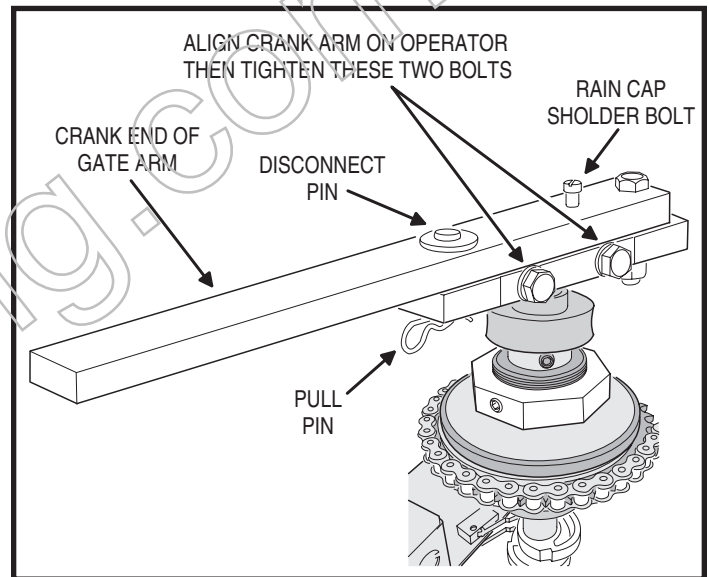

Figure 6. Installing Gate Arm on Operator

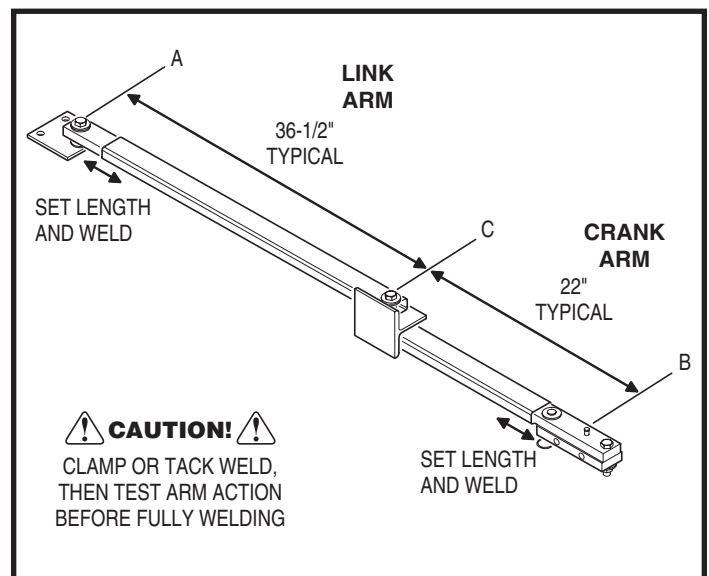

Figure 7. Setting Gate Arm Lengths

## Operator Setup

### Controller Access

The Controller in models SWR, SWC and SWD is hinged for access and can be removed without taking off the operator's cover. It swings down for installation, programming, and troubleshooting access (see Figure 8). Under most circumstances you will not need to remove the Controller.

To access the Controller, lift the metal tab below the AC power switch and swing the Controller down. The Controller is protected by a plastic dust cover. To remove the dust cover, loosen the cover's wing-screw and lift the cover off.

To remove the Controller from the operator, slide the assembly to the right until the hinges release. Once freed, you can turn the Controller slightly and remove it from the operator. Be careful not to pull on the cables too hard.

### AC Power Connection



**WARNING**



**ALL AC ELECTRICAL CONNECTIONS TO THE POWER SOURCE AND THE OPERATOR MUST BE MADE BY A LICENSED ELECTRICIAN AND MUST OBSERVE ALL NATIONAL AND LOCAL ELECTRICAL CODES**

All Linear gate operators are supplied with a power disconnect switch to turn on and off the power available to the operator (see Figure 9). Following wiring specifications on Page 2, incoming power should be brought into the operator and connected to the labeled pigtail leads from the disconnect box. A wiring connections print can be found on the label inside the cover of the operator.

Proper thermal protection is supplied with the operator. The motor contains a thermal overload protector to guard from overheating the motor due to overload or high-frequency operation. This overload protector will reset automatically after the motor cools down.

### Earth Ground

Install a ground rod and connect it to the operator's frame in every gate operator installation. A good earth ground is necessary to allow the Controller's built-in surge and lightning protection circuitry to work effectively. **The physical bolting of the operator to the mounting pad is not sufficient for a good earth ground.**

✓ **NOTE:** Do not splice the ground wire. Use a single piece of solid copper 12 AWG wire between the ground rod and the operator.

1. Install an 8-foot long copper ground rod next to the operator mounting pad within three feet of the operator.
2. Use a clamp to connect a solid copper 12 AWG ground wire to the ground rod.
3. Route the ground wire to the operator.
4. Connect the ground wire to the operator's frame.

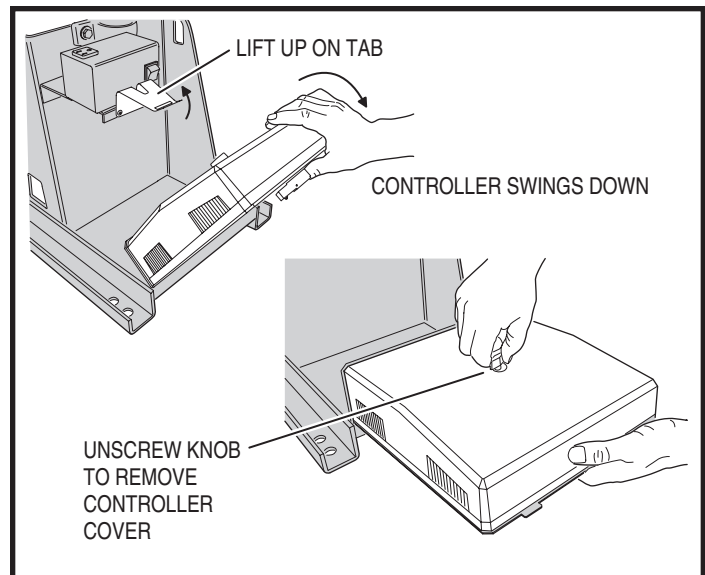

Figure 8. Controller Access

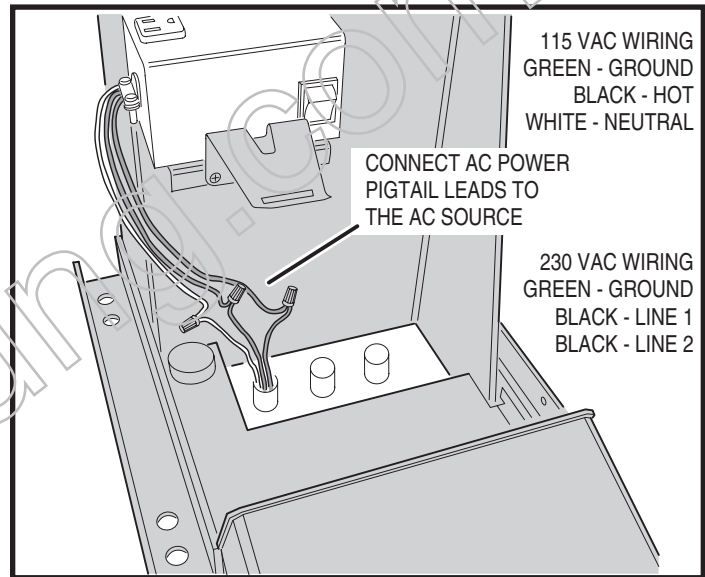

Figure 9. Power Disconnect Box Wiring

## Operator Setup (Continued)

### Limit Cam Rough Adjustment

The limit cams are not preset at the factory and must be adjusted for each installation. The limit switches are activated by two rotating limit cams attached to the drive shaft (see Figure 10). The Controller is factory set for right hand installations. The top cam is for **OPEN** and the bottom cam is for **CLOSE**. The cams flip their definition in left hand installations (see left-right hand programming on Page 12).

1. With the gate connected to the gate operator in a mid-travel position, **the power disconnect switch turned OFF**, and the torque limiter set loose enough to slip freely, **manually** move the gate by hand to its fully open position.
2. Once the gate is in the fully open position, set the **OPEN** limit cam so that it has just triggered its switch (see Figure 10).
3. Manually move the gate to its fully closed position, set the **CLOSE** limit cam so that it has just triggered its switch (see Figure 10).

### Torque Limiter Adjustment

✓ **NOTE:** The open and close current sensing may need to be adjusted before performing the following two steps. See Page 13.

This operator may be supplied with an optional torque limiter. Before adjusting the torque limiter, make sure the gate is in good working condition. With the gate disconnected from the gate arm, one person should be able to move the gate by hand. Be certain the gate moves freely and without binding throughout its travel.

Torque limiters are set light at the factory. They must be adjusted during installation, preferably after limit cams have been manually set. With the gate arm and gate attached, adjust the torque limiter tight enough to keep it from slipping during normal operation. The inherent entrapment protection (current sensing) feature must activate prior to any slipping of the torque limiter. See pages 13-14 for current sense setting.

To adjust the torque limiter in models SWR and SWD:

1. Loosen the set screw on the torque limiter adjustment nut.
2. Cycle the gate open and closed while observing the torque limiter action. **TURN THE OPERATOR POWER DISCONNECT SWITCH OFF BEFORE MAKING ANY ADJUSTMENTS.**  
*To increase the torque,* turn the adjustment nut clockwise one flat, or 1/6 turn, at a time until desired output is obtained.  
*To reduce the torque,* turn the adjustment nut counterclockwise one flat, or 1/6 turn, at a time until desired output is obtained.
3. When finished, tighten the set screw on the torque limiter adjustment nut.

### Limit Cam Fine Adjustment

After finishing the rough limit cam adjustments and torque limiter adjustment (if optional torque limiter is installed), reposition the gate to approximately the center of travel.

1. Turn the power disconnect switch **ON**.
2. Stand clear of any moving parts and press the **OPEN** button.
3. After the gate opens, press the **CLOSE** button.
4. Observe the gate in both directions as it runs through each complete cycle. Adjust the open or close limit cams again if necessary. If the gate stops during travel, you may need to adjust the Open or Close Current Setting or the Maximum Run Timer (see Pages 13-14).

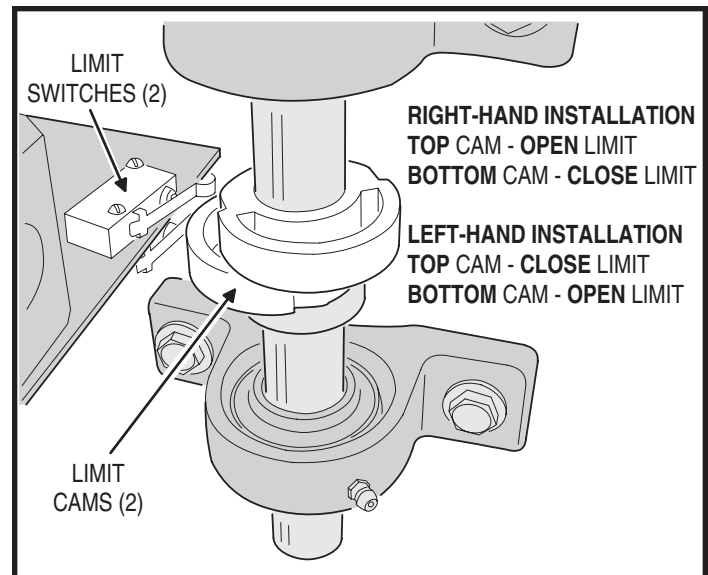

Figure 10. Setting Limit Cams

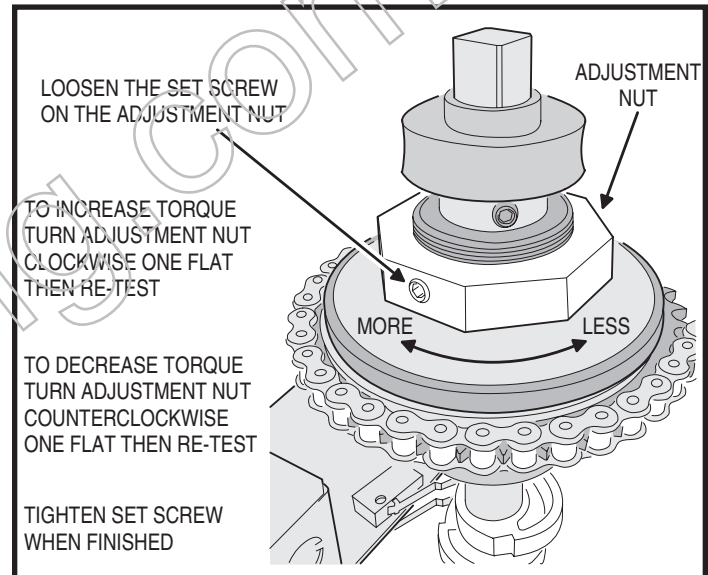

Figure 11. Adjusting the Torque Limiter

## ⚠ CAUTION ⚠

**If the operator is installed in a left-hand installation. Set the Controller to left-hand operation BEFORE running the operator for the fine setting of the limit cams. Failure to do so will result in over-shooting the limit switches, and may cause damage to the operator and/or gate. Refer to programming on Page 12.**













































