

Operating Instructions
MAGSTOP Traffic Barrier
MIB 10-C090
Controller Unit

© 2000 by Magnetic Autocontrol GmbH, 79650 Schopfheim, Germany

1. Safety

1.1 General safety information

This MAGSTOP gate system has been designed, built and tested using state-of-the-art technology and left our factory only after having satisfied stringent safety and reliability criteria. Nevertheless the gate system can represent a risk to persons and property if it is not operated correctly. These operating instructions must therefore be read in their entirety and all safety information contained therein must be complied with.

The manufacturer shall refuse to accept liability and shall withdraw warranty cover if this gate system is used incorrectly or is used for a purpose for which it was not intended.

1.2 Intended use

The MAGSTOP MIB 10 gate may only be used at tollbooths (motorways, major roads etc.).

The MAGTRONIC controller units have been specially designed for controlling this Magnetic barrier.

Any other use of these barrier systems is not permitted.

Modifications or changes to the barrier or to the control modules is prohibited.

Only original Magnetic spare parts and accessories may be used.

1.3 Safety symbols used in this handbook

The following symbols are used in these operating instructions to indicate potential risks and other safety information.



Warning!

This symbol is used in this manual to designate those actions or states which represent a potential danger to life and limb. Please read these instructions very carefully.



Caution!

This symbol is used in this manual to designate those actions or states which represent a potential hazard to property and equipment. Please read these instructions very carefully.



Note!

This symbol is used in this manual to designate useful information for the operator.



1.4 Operational safety

A safe clearance distance of at least 500 mm must be provided between the tip of the gate arm and the closest solid obstacle (building, wall, fence etc.).

The gate operating elements must be installed at a position from which the gate can be seen directly.

The motion of the gate arm must be directly observable by the person operating the gate.

Whilst the gate arm is in motion nobody and no object must be in the immediate vicinity of the gate.

If the gate and operating elements have been installed in a fixed manner, an all-pole lockable master switch must be used.

The assembly and installation instructions must be complied with in their entirety.

Any alterations must have received prior confirmation from Magnetic. The gate arm fixture is designed to withstand wind speeds of up to a maximum of 10 on the Beaufort scale (= 500 N/m²). If higher wind speeds are expected, a modified gate arm fixture must be agreed with Magnetic.

All electrical connections, wiring work and exchange of components may only be performed by appropriately trained electrical technicians.

Before opening, the machines must be disconnected from the mains.

All technical modifications or changes to the barrier system are prohibited.

1.5 Technical developments

The manufacturer reserves the right to modify without prior notice the technical specifications in order to accommodate the latest technical developments. Magnetic is happy to provide information on the status of existing operating instructions and on any alterations and extensions that may be relevant.

1.6 Warranty

Magnetic provides a warranty on its gates that covers all mechanical and electrical components, but excludes parts subject to wear, for a period of two years from the date of first use or for a maximum of three years from the date on which the system was delivered provided that the operating instructions have been complied with, no unauthorized servicing of machine components has taken place, and that no mechanical damage to the machines is evident.

2. Assembly and installation

2.1 Constructing the foundation for the MIB gates and the MEC-10 N/H/L control pillar

To ensure that the units are stable even when loaded, a foundation with the following dimensions must be provided:

Depth of foundation: at least 800 mm (frost-free)
Base area of foundation: 500 x 600 mm

The base of the foundation is 100 mm larger towards the vehicle side than in the upper section of the foundation (see Fig. S0101).

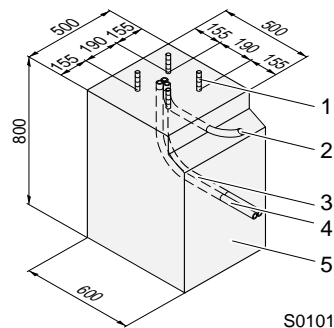

Fig. S0101
View of the foundation with its dimensions in mm

1. shear connector (four in total)
2. empty conduit for induction loop connections, dia. 29 mm
3. empty conduit for power supply cable, dia. 29 mm
4. empty conduit for control cables, dia. 29 mm
5. concrete foundation (BH PC 250, strength = 25 N/mm²)

Empty conduit pipes each with a diameter of 29 mm must be installed to take the mains supply cable, the control cables and, possibly, the induction loop connections. (barrier: 2 or 3 empty conduit pipes; control pillar: 2 empty conduit pipes). A reinforcing steel cage is absolutely essential for the stability of the foundation (see Fig. S0102).

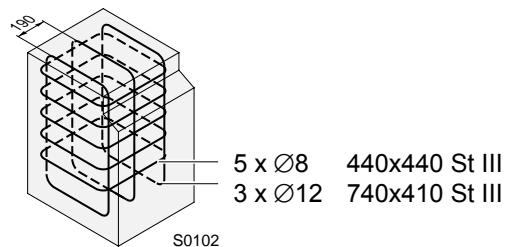

Fig. S0102
Reinforcing cage for the concrete foundation

The foundation hole is filled with BH PC 250 grade concrete (strength: 25 N/m²). The plinth face must be carefully smoothed so that the gate housing can be positioned in a **level and horizontal** manner.

Once the concrete has set to an adequate hardness, the holes for the shear connectors can be drilled into the face of the plinth in accordance with the dimensions shown in Fig. S0101.

Distance between drill holes: 190 mm (arranged in a square, see Fig. S0101)
Hole diameter: 10 mm
Depth of hole: 80 mm
Once the holes have been drilled, the four M8 x 160 shear connectors can be set in place.

2.2 Installing the induction loops

The following section describes the standard installation of an induction loop. The basic function of loop A is as a safety and closing loop i.e. the gate remains open for as long as a vehicle is above the loop. The barrier closes automatically only after the vehicle has moved away from the loop A separate loop detector i.e. the MID-detector is required.

Non-standard installations will require prior consultation with Magnetic. The standard installation is illustrated in Fig. S0103.

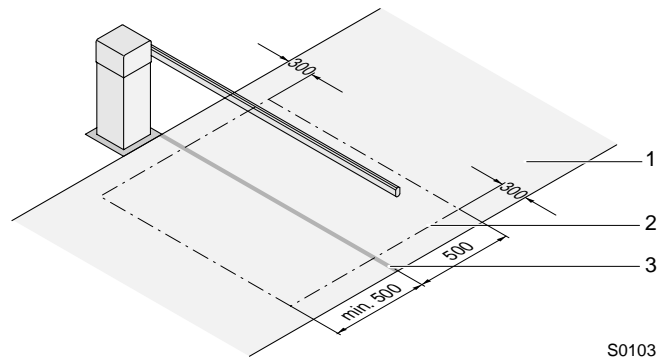

Fig. S0103
Example of how an induction loop is installed

1.lane 2.induction loop
3.Projection of the barrier boom onto the surface of the lane assuming standard loop installation

The following points must be considered when installing the induction loop:

- The loop must be positioned so that it is symmetrical about the vertical plane through the gate arm. It must be recalled that the barrier boom is attached to one side of the gate housing!
- The distance from the gate arm to the front and rear portions of the induction loop must be at least 500 mm. If in non-standard installations (e.g. in multi-storey car parks) significantly different distances arise, prior consultation with Magnetic should be sought.
- The distance between the induction loop and the tip of the gate arm and the distance between the induction loop and the barrier housing should be approximately 300 mm.
- The loop must be installed so that it remains stationary when vehicles are passing the barrier.
- If the lane has iron reinforcing bars then the induction loop should be positioned at least 50 mm away from the reinforcing bars. Metals close to the induction loop reduce its sensitivity.



- The supply line to the loop must not be longer than 15 m. The cable must not be coiled up within the barrier housing but should be cut to the appropriate length instead. The supply cable must be twisted about twenty times per metre. Once the loop has been installed, a check must be made that the resistance is $< 2 \Omega$ and that the insulation resistance is $> 1 M\Omega$ (for inductance value - see technical data). If the values quoted are not registered, the cable is maybe defective and should be replaced

Procedure for installing an induction loop in bitumen or asphalt:

- The induction loops are available from Magnetic as ready-to-install cables (type: KAS 1-KAS 5) and can be supplied in a range of lengths.
- Alternatively, a loop can be manufactured from a single wire with a 0.75 - 1.5 mm² cross-section. The inductance of the loop must lie between 70 and 500 μH , which is usually achieved by making three to five windings.
- Using an angle grinder, a channel is cut to a depth of 30 mm into the bitumen or asphalt surface (see Fig. S0104). The channel must have a uniform depth over its entire length.
- The cable is laid carefully into the channel and pressed down uniformly using a blunt object (e.g. a wooden or plastic spatula). Small wooden wedges can be used to hold the cable in position.



Caution!
The loop cable insulation must not be damaged during installation!

The loop cable must be completely covered with sealing compound!

Fig. S0104
Installing an induction loop in asphalt

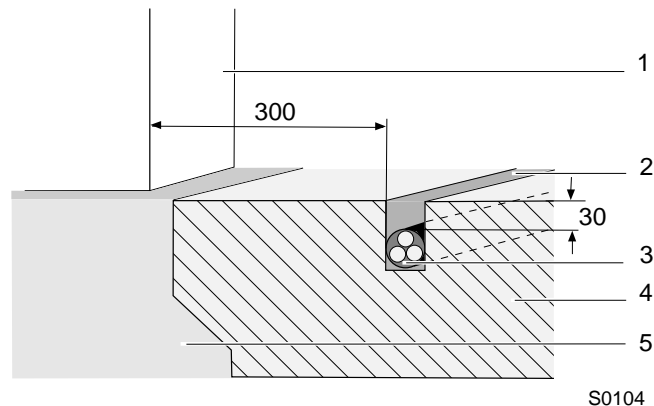

1.gate housing 2.channel with sealing compound 3.loop cable
4.asphalt covering 5.concrete foundation

- The end of the cable must now be pushed through the empty conduit pipe
- Finally, the channel is sealed using a pourable sealing compound. When poured into the channel, the temperature of the sealing compound must not exceed 90 °C.
- If a hot sealing compound is used (bitumen or similar), heat-resistant cables must be selected.

Procedure for installing an induction loop under interlocking paving stones:

- When installing an induction cable beneath paving stones, a ready-to-install cable (type: KAS 1-KAS 5) from Magnetic must be used.
- The induction loop cable must be laid in sand in such a way that its length is unchanged and it suffers no damage when vehicles are passing the barrier.
- A minimum distance of 30 mm between the induction loop cable and the paving stones is required (see Fig. S0105).

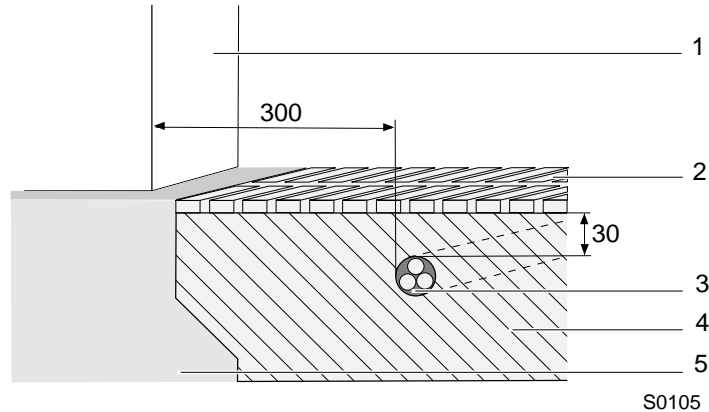
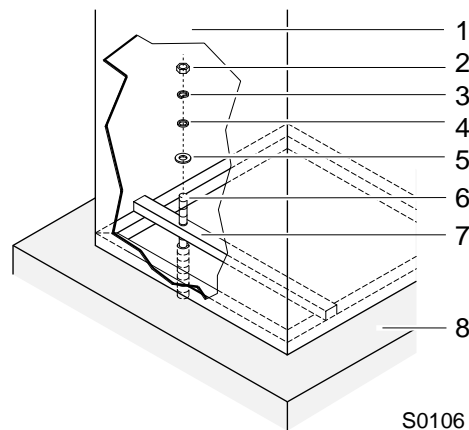

Fig. S0105:
Installing an induction loop under paving stones

1 gate housing 2 paving stones 3 loop cable /
4 sand bed 5 crete foundation

2.3 Assembling the housing

The gate housing is positioned vertically on the upper face of the foundation and secured using the fastenings in assembly set A that is supplied with the system. (See Fig. S0106). In order to be able to adjust the housing later, the nuts are only lightly tightened initially.



Fig, S0106
Fastening the gate housing to the foundation

1 gate housing 2 nut 3 split washer

4 plain washer
7 U-section

5 plain washer
8 concrete foundation

6 masonry anchor

2.4 Installing the flange and the barrier boom

The flange is fastened to the drive shaft using two M10 x 35 hexagon socket screws and spring washers.

The special gate arm bracket (not delivered by Magnetic) is clamped to the flange using the fastenings fitted to the flange.

2.5 Basic mechanical settings.

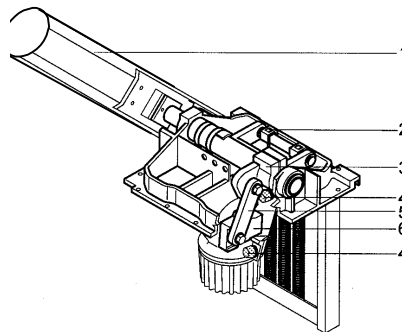

S0225

Fig. S0225
Drive unit

- 1 gate arm
- 2 adjuster screw to set spring tension, with safety clips
- 3 clamping lever for flanged shaft
- 4 rubber buffer
- 5 connector piece
- 6 clamping lever for motor

S0225



Warning!

When tensioned, the springs and the gate arm exert considerable forces on the drive unit and there is thus a potential risk of injury.

Any work on the BDU drive unit must therefore be carried out only when the springs are not under tension and when the gate arm has been secured or removed!

2.6 Testing / readjustment of the springs.

The gate is set to open automatically in the event of a power failure, the spring tension is greater than it is necessary to balance the boom.

Testing the spring settings:

1. Open the gate door, swing out the mounting plate, unlock the cover and remove.
2. Disconnect the power supply.
3. The gate arm will open automatically.

Readjusting the spring settings:

- 1 Remove the two safety clips from both spring adjustment screws. Tighten or loosen the screws on the left and the right uniformly until the gate arm move automatically to the open position, when power failure occurs.

Attention: For the test of the automatic opening function in case of power failure it is necessary that power is on. When power failes, the controllers gives a kick to the motor to bring the lever system out of the dead point and the arm can move upwards.

2. Replace the screw retainers (safety clips).

2.7 Readjusting the position of the barrier boom

To readjust the position of the gate arm (for example, after excessive force has been applied), proceed as follows:

1. Open the gate door, swing out the mounting plate, unlock the cover and remove.
2. Raise the barrier boom by giving an opening contact.
3. Make sure that no contact for closing can be given to the controller
4. Loosen the two clamping screws on the clamping lever of the flanged shaft just enough so that the barrier boom is held safely in position while still allowing it to be repositioned by hand.
5. Readjust the position of the barrier boom (vertical position).
6. Retighten the clamping screws using a torque wrench (75 ftlb).

3. Power supply connection



Fig. F0103.
Power supply connection

F0103

Important! The mains voltage may only be connected to the terminals L N of the connector unit mounted on the left side of the gate housing and the GND to the grounding stud of the housing.

Never connect the supply lead directly to the controller unit!

4. Starting up

When the gate is set and fixed to the concrete and all connections (contacts for OPEN and CLOSE, safety devices, power supply) are made, the gate will start automatically with a reference cycle.

For this the gate arm will open slowly to the upper position. The motor lever will press the end stop of this direction for some seconds. Then the motor lever will move a few degrees back to its normal end position OPEN.

The first movement into the closed position will be done by a very low speed (appr. 3s to close). This is a safety device to check, if the parameters are set correctly. All following signals will move the gate with the desired and adjusted speed.

Reset of break-away function (option)

If there is a break away contact mounted to the boom flange a reset pulse to the push button S4 of the electronic plate ("reset after break away") is required to deactivate the safety function which will hold open the gate arm.

This is a safety function to protect the service personal when after a break away of the gate arm the arm is brought back to its normal position.

5. Controller for MIB10 gates

The controller unit has been specially designed for use with MIB 10 gates.

Most gate system configurations can be realized using the standard version of the controller.

The position of the gate arm is continuously calculated by the controller. The information comes from the hall-sensors inside of the motor. This replaces the limit switch that is used in conventional barrier control systems. The combination of the hall sensor and the controller unit guarantees the best possible control of the gate arm movement.

Software modifications are normally included at the factory but they can also be loaded into the controller unit at some later date. A special software tool for this programming is necessary.

The gate is correctly wired at the factory and is supplied ready for immediate connection.

Electrical connections that need to be made during installation are illustrated in Fig. S0226.

Note!

If special functions are included, the connections will differ from those shown here. Please refer to the enclosed additional wiring scheme.

S0226

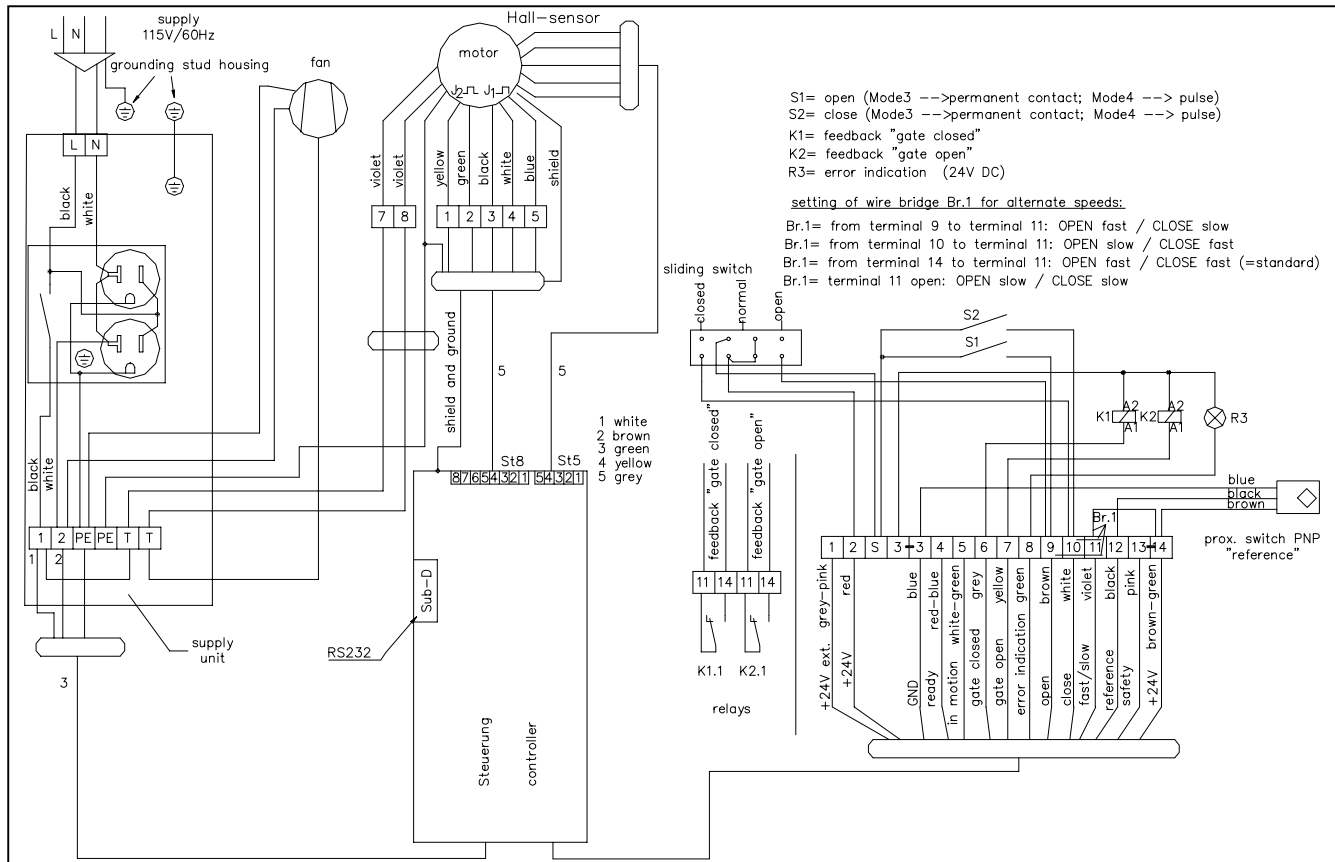

5.1. Command generators: their connection and function in the different operating modes

Important note: All command generators (e.g. push buttons, light barriers, limit switches) must be connected as voltage-free contacts. Contact Magnetic for advice before connecting command generators with open collector outputs.

Program 1 (Mode 3):

The gate is controlled by two switches.

Wiring of the switches see wiring diagram S1 and S2.

The switch for OPEN is prior to the DOWN switch, that means we both contacts are closed, the gate will open.

Connections:

Potential-free contact between +24V (terminal S) and terminal 9 (S1) and terminal 10 (S2).

Additional safety devices can be connected to terminal 14 and 13. These must function as break contacts.

Program 2 (Mode 4):

The barrier is opened and closed by two separate command generators (pulsed).

Open: contact between +24V (terminal S) and terminal 10 (S2).

Close: contact between +24V (terminal S) and terminal 9 (S1).

Additional safety devices can be connected to terminal 14 and 13. These must function as break contacts.

6. Technical data

6.1 MAGSTOP barrier

MIB 10

Maximum boom length	max. 3000 mm	round boom	dia. 75mm
Maximum boom length	max. 2500 mm	octogonal boom	100x55mm
Opening/closing time	0, 6/1.2 sec	adjustable via software-tool	
Power consumption	max. 480 W		
Housing	zinc-plated sheet steel color RAL 2000		
Housing dimensions	350 x 350x 1010mm (W x D x H)		
Foundation base frame	stainless steel		
Weight (without arm)	55 kg		
Operating temp. range	-20°C to +50°C		
Drive	brushless DC motor		

6.2 Controller unit

Voltage (+/- 10%)	volt	115
frequency	hertz	50 - 60
Max. power consumption	watt	20
Fuse		T10A
I/O voltage		24 V DC
RS232-communication		1 SUB-D
Mode settings		2
No. of input channels		5
No. of open collector outp.	max.50mA/24V DC	5
No of LED's		3
Operating temp range	° C	0 - 55
Protection system	IP	40
Weight	gram	2000
Dimensions	mm (L - W - H)	320 x 100 x 110

7. Technical support

If operational faults arise which cannot be dealt with by your technical staff, please contact our authorized customer service agents or specialist suppliers for assistance.

When contacting our technical support service please have available the barrier type, serial number, version, etc. which you will find printed on the type plate on the barrier housing.

8. Spare parts and accessories

The spare parts and accessories for your barrier system are listed in our separate spare parts and accessories catalogue which is available from Magnetic or from one of our authorized distributors.