



Reno A & E
 4655 Aircenter Circle
 Reno, NV 89502-5948 USA
 Telephone: (775) 826-2020
 Fax: (775) 826-9191
 Website: www.renoae.com
 E-mail: contact@renoae.com



Engineering Excellence!

Loop Installation

The vehicle detection characteristics of an inductive loop detector are greatly influenced by the loop size and its proximity to moving metal objects such as gates. Vehicles such as small motorcycles and high bed trucks can be reliably detected if the proper size loop is selected. If the loop is placed too close to a moving metal gate, the detector may detect the gate. The diagram below is intended as a reference for the dimensions that will influence the detection characteristics.

General Rules

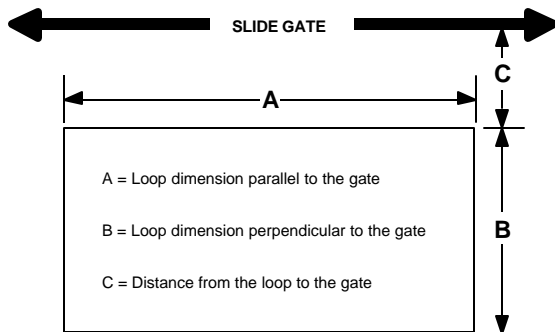

1. The detection height for a loop is 2/3rds the shortest leg (A or B) of the loop. Example: Short leg = 6', Height = 4'.
2. As leg A is made longer, distance C will need to increase. A loop with A = 6 ft, distance C = 3 ft; A = 9 ft, C = 4 ft; A = 12 ft, C = 4.5 ft; A = 15 ft, C = 5ft; A = 18 ft, C = 5.5 ft; A = 21 ft, C = 6 ft.
3. For reliable detection of small motorcycles, legs A and B should not exceed 6 feet.

Loop Installation - Saw Cut Type

1. Mark the loop layout on the pavement. Be aware that sharp inside corners can damage the loop wire insulation.
2. Set the saw to cut to a depth (typically 2" to 2.5") that insures a minimum of 1" from the top of the wire to pavement surface. The saw cut width should be larger than the wire diameter to avoid damage to the wire insulation when the wire is placed in the saw slot. Cut the loop and feeder slots. Remove sharp inside corners. Remove all debris from the saw slot with compressed air. Check that the bottom of the slot is smooth.
3. It is highly recommended that a continuous length of wire be used to form the loop and feeder to the detector. Loop wire is typically 14, 16, 18, or 20 AWG with cross-linked polyethylene insulation. Use a wood stick or roller to insert the wire to the bottom of the saw slot (do not use sharp objects). Wrap the wire in the loop saw slot until the desired number of turns is reached. Each turn of wire must lay flat on top of the previous turn.
4. The wire must be twisted together a minimum of 6 twists per foot from the end of the saw slot to the detector.
5. The wire must be held firmly in the slot with 1" pieces of backer rod every 1 to 2 feet. This prevents the wire from floating when the loop sealant is applied.
6. Apply the sealant. The sealant selected should have good adhering properties with contraction and expansion characteristics similar to those of the pavement material.

LOOP PERIMETER	NUMBER OF TURNS
10 feet - 13 feet	5
14 feet - 26 feet	4
27 feet - 45 feet	3
46 feet - 100 feet	2
101 feet and up	1

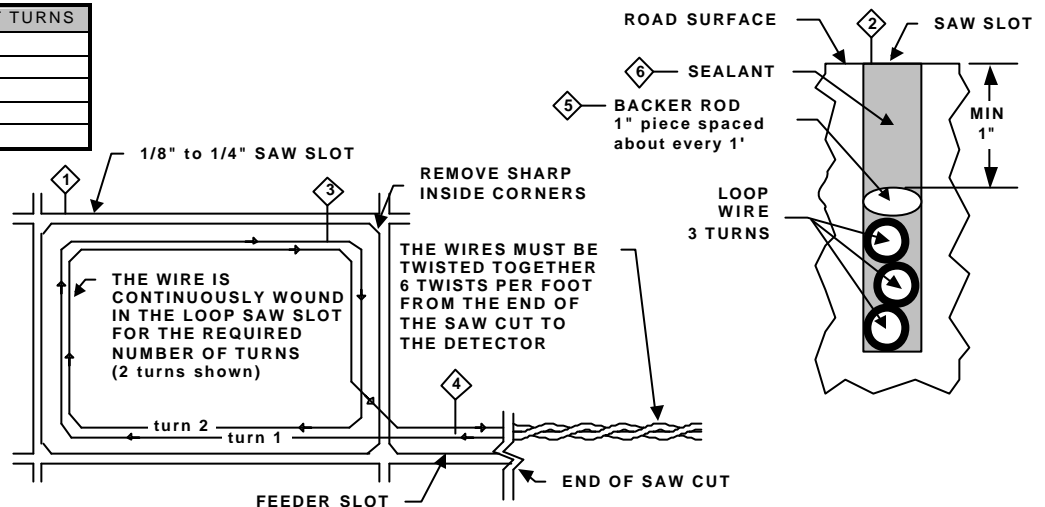

Recommended Loop Wire:

Reno LW-120 for 1/8" slots
 Reno LW-116-S for 1/4" slots