

Reno A & E
4655 Aircenter Circle
Reno, Nevada 89502
USA



Telephone: (775) 826-2020
Facsimile: (775) 826-9191
Internet: www.renoae.com
e-mail: contact@renoae.com



MODEL L-ATG OPERATION MANUAL

Firmware Version 1.01



**Built-in
Loop Analyzer**

Single Channel Anti-tailgating Inductive Loop Vehicle Detector

3/27/07

This page intentionally left blank.

Upswung.com

MODEL L-ATG OPERATION MANUAL

TABLE OF CONTENTS

1.0	GENERAL DESCRIPTION	5
2.0	GENERAL CHARACTERISTICS	7
2.1	Loop Frequency	7
2.2	Sensitivity Level	7
2.3	Call Delay Time	7
2.4	Call Extension Time	7
2.5	Max Presence Time	7
2.6	Option 1 - Display Loop Inductance (L) and % Loop Inductance Change ($-\Delta L/L$).....	7
2.7	Option 2 - Display Vehicle Count.....	8
2.8	Option 3 - Relay B Buzzer.....	8
2.9	Option 4 - Training Mode.....	8
2.10	Option 5 - Relay B Output Mode.....	8
2.11	Option 6 - Control Input Active High / Low.....	8
3.0	SPECIFICATIONS	9
3.1	Physical.....	9
3.2	Electrical	9
3.3	Operational	9
3.4	TABLE: Sensitivity, $-\Delta L/L$, & Response Times.....	10
3.5	TABLE: Default Settings.....	10
3.6	TABLE: Pin Assignments.....	10
4.0	USER INTERFACE.....	11
5.0	INSTALLATION AND SET-UP	12
5.1	Program Mode Display Screens.....	12
5.2	Normal Mode Display Screens	14
5.3	Option 4 - Training Mode.....	17
5.4	Option 5 - Relay B Output Mode.....	17
5.5	Option 6 - Control Input Active High / Low.....	20
5.6	Loop Fail Indications	20
5.7	Setting Sensitivity Using the Bargraph	20
5.8	Setting Sensitivity for Motorcycle Detection Using the Bargraph.....	21
5.9	Full Restore To Factory Default Settings.....	21
5.10	Display Test.....	21
6.0	BLOCK DIAGRAM	22
7.0	THEORY OF OPERATION	23
8.0	MAINTENANCE AND TROUBLESHOOTING	24
8.1	Troubleshooting Power Problems.....	24
8.2	Troubleshooting Initialization Problems.....	24
8.3	Troubleshooting Loop Fail Problems	25
8.4	Troubleshooting Intermittent Loop Fail Problems.....	26
8.5	Troubleshooting Intermittent Detector Lock Ups	26
8.6	Troubleshooting Delay Problems.....	Error! Bookmark not defined.
8.7	Things To Know About Loops	27

This page intentionally left blank.

Upswung.com

1.0 GENERAL DESCRIPTION

This Operation Manual was written for people installing, operating, and maintaining Reno A&E Model L-ATG Series inductive loop vehicle detectors. The Model L-ATG is a single channel, shelf mount type, inductive loop vehicle detector designed to provide accurate passenger vehicle counts and/or identification of tailgating passenger vehicles passing over small inductive loops used in revenue control and controlled access applications. Typical loop size is 2.5 feet by 6 feet with three (3), four (4), or five (5) turns. Please note that the Model L-ATG has been specifically designed and tested to count and/or identify *passenger vehicles*, not commercial vehicles or vehicles towing trailers.

Accurate vehicle counts are important in revenue control and controlled access applications. Standard inductive loop vehicle detectors provide a single count for each vehicle detection. If the vehicles being counted are closely spaced and multiple vehicles pass over a loop in a manner that the detector is continuously in detection, the detector will only count one vehicle. In another scenario, a metal object can be placed in the area defined by the detection loop to cause a continuous detect output. Multiple vehicles can then pass over the detection area and not be counted. The Model L-ATG will accurately count vehicles spaced as closely as bumper to bumper. Metal objects placed in the area of the loop are ignored as well.

The Model L-ATG accumulates vehicle counts and can be configured to display the accumulated count on a front panel Liquid Crystal Display (LCD). The Model L-ATG features two (2) relay outputs. Relay A, the presence output, is used for vehicle presence detection. Relay B, the secondary output, can be used to provide a vehicle count indication to an external device or provide an indication that a tailgating incident or vehicle entry has occurred.

Following installation of the Model L-ATG detector, a simple one-time calibration is required. Calibration takes into account possible environmental effects on the loop, such as reinforcing steel in the pavement, metallic objects permanently located in close proximity to the loop, number of turns in the loop, etc.

The Model L-ATG incorporates a microcontroller that monitors and processes signals from the loop / lead-in circuit. The microcontroller uses these inputs to determine how to control the detector outputs. A Liquid Crystal Display (LCD), a light emitting diode (LED), and three front panel pushbuttons are used to display and program all detector functions. Several diagnostic modes are available to aid technicians and service personnel in troubleshooting detection problems.

The use of a LCD is what distinguishes this detector from that of other manufacturers. It allows more information, never before available, to be displayed to the user during normal operation of the detector. The LCD makes it easy to view and adjust all programmable detector options and settings. It is no longer necessary to check or change detector settings with DIP switches. An eight-segment bargraph at the top of the LCD can be used to provide a graphical representation of the relative change of inductance as seen by the detector at the current sensitivity level. The bargraph automatically takes into account loop size, loop inductance, number of turns, loop geometry, lead-in length, etc. The bargraph functions as a sliding scale that relates to the programmed Sensitivity Level. The first (left-most) bargraph segment represents the minimum inductance change necessary for the detector to output a call at the currently selected sensitivity level. Larger inductance changes will indicate more segments. Each additional segment indicates that the next sensitivity level has also been met or exceeded. When used in this manner, the bargraph provides an indication of whether the sensitivity is set too high or too low, facilitating the ideal setting of the sensitivity level.

All programmed settings are stored in non-volatile memory and can only be changed by programming new settings. Loss of power or a detector reset will not change any of the programmed settings. If a loop failure occurs, the LCD will display the type of loop failure as **L lo** (for -25% change or shorted loop conditions) or **L hi** (for +25% change or open loop conditions). Each loop failure is counted and accumulated in the Loop Failure Memory. The number of loop failures since the last detector reset or power interruption is very useful information to have available during analysis of intermittent loop operation.

When operating in the Program Mode, the Model L-ATG displays the real time loop frequency reading. The eight frequency settings can be incremented or decremented to provide precise frequency readings, removing any guesswork when changing frequency settings to eliminate crosstalk. NOTE: Adjacent loops connected to different channels of a non-scanning detector or different scanning detectors should be set to different frequencies with maximum separation.

The Reno A&E Model L-ATG utilizes the first major innovation in inductive loop detectors since the introduction of digital detectors. The programming of all of the detector's parameters with three normally open pushbutton switches not only simplifies setup by removing binary coded DIP switches, but also increases the reliability of the detector by eliminating the dependence on switch contacts during normal operation. The detailed descriptions displayed on the LCD eliminate the interpretation of numerous LED flash rates to determine the detector status. In addition, the Model L-ATG offers the versatility of software control. Special functions are possible with a simple change of the socket-mounted microprocessor. Special functions are defined as unique options (e.g. Option 4, Option 6, etc.). Special option functions are activated through the use of the LCD menu option programming.

The Model L-ATG Series is comprised of the following detectors:

- Model L-ATG-1 For applications calling for a single channel, 120 volt AC, shelf mount detector with the capability to detect and identify tailgating vehicles.
- Model L-ATG-5 For applications calling for a single channel, low voltage (12 or 24 volt DC or 24 volt AC), shelf mount detector with the capability to detect and identify tailgating vehicles.
- Model L-ATG-35 For applications calling for a single channel, 240 volt AC, shelf mount detector with the capability to detect and identify tailgating vehicles.

Upswung.com

2.0 GENERAL CHARACTERISTICS

2.1 Loop Frequency

There are eight (8) selectable loop frequency settings (normally in the range of 20 to 100 kilohertz). The actual loop operating frequency is a function of the loop / lead-in network and the components of the loop oscillator circuit. The digital display of the actual loop operating frequency for each setting makes it easy to quickly identify and eliminate crosstalk in the most difficult to configure intersections. The frequency display is typically very stable when the loop is vacant and vehicles are not passing nearby the loops. If the reading is varying by more than ± 1 in the last digit, this is an indication of possible crosstalk between loops.

2.2 Sensitivity Level

There are nine (9) selectable sensitivity levels, plus Continuous-Call and Channel-Off. The sensitivity levels are designed so that a one level increase actually doubles the sensitivity and a one level decrease halves the sensitivity. A unique bargraph displayed on the LCD makes it easy to quickly set sensitivity at the ideal level for any loop / lead-in network configuration. (See Section 3.4 for actual detection levels at each sensitivity level.)

CONTINUOUS-CALL: When set to the Continuous-Call state, the detector's output is continuously in the Call state regardless of the presence or absence of vehicles over the loop. The loop oscillator is disabled when in the Continuous-Call state. This state is indicated by **CALL** flashing on the LCD. This option is selected from the Sensitivity menu in Program Mode and is useful when troubleshooting equipment related problems.

CHANNEL-OFF: When set to the Channel-Off state, the detector's output is continuously in the No Call state regardless of the presence or absence of vehicles over the loop. The loop oscillator is disabled when in the Channel-Off State. This state is indicated by **OFF** flashing on the LCD. This option is selected from the Sensitivity menu in Program Mode and is useful when troubleshooting equipment related problems.

2.3 Call Delay Time

The Model L-ATG has two (2) output relays. Call Delay Time applies to Relay A only and can be adjusted from 0 to 255 seconds in one-second steps. Call Delay time starts counting down when a vehicle enters the loop detection zone. The remaining Call Delay time is continuously displayed on the LCD.

2.4 Call Extension Time

The Model L-ATG has two (2) output relays. Call Delay Time applies to Relay A only and can be adjusted from 0 to 25.5 seconds in 0.1-second steps. Extension time starts counting down when the last vehicle clears the loop detection zone. The remaining Call Extension time is continuously displayed on the LCD. Any vehicle entering the loop detection zone during the Call Extension time period causes the detector to return to the Detect state, and later, when the last vehicle clears the loop detection zone, the full Call Extension time starts counting down again.

2.5 Max Presence Time

When Max Presence Time is set to OFF, True Presence™ mode is selected and the detector will provide a Call output as long as a vehicle is present in the loop detection zone. TruePresence™ time applies only for normal size passenger vehicles and for normal size loops (approximately 10 ft² to 120 ft²). When activated, the detector's Max Presence timer is adjustable from 1 to 999 seconds in one-second steps. The Max Presence function is used to limit presence time by automatically resetting the detector. If this function is enabled (ON), the Max Presence timer begins counting down when a call is initiated and the remaining time is continuously displayed on the LCD. If the loop becomes vacant before the Max Presence timer reaches zero, the call is dropped and no automatic reset occurs. When the Max Presence timer reaches zero, the detector is automatically reset.

2.6 Option 1 - Display Loop Inductance (L) and % Loop Inductance Change (-ΔL/L)

Pressing either the ▲ (UP) or ▼ (DOWN) pushbutton toggles Option 1 between **ON** and **OFF**. When Option 1 is **OFF**, the LCD displays three dashed lines (- - -) during a No Call state or **CALL** and the Call strength (via the LCD bargraph display) during a Call state.

When Option 1 is **ON** and the detector is operating in normal display mode, the LCD continuously displays the Loop Inductance value (L) in microhenries (μH) between 15 and 2500 μH. By recording the inductance of the loop / lead-in circuit when it is first installed, the actual inductance can be compared to the expected inductance to help identify defective loop / lead-in circuits. Loop / lead-in inductance can be easily estimated using the simple formulas included in Section 8.7 of this manual. When a vehicle is detected, the Call is indicated by means of the DETECT LED and the LCD bargraph display. While in the Call state, the LCD also displays the percentage of inductance change (-ΔL/L value) while a vehicle is detected. The maximum -ΔL/L that has occurred is displayed for two seconds unless a greater change occurs. The count down of the Delay, Extension, and/or Max Presence timers is not displayed when Option 1 is **ON**. Once set to **ON**, Option 1 will turn **OFF** after 15 minutes have elapsed.

2.7 Option 2 - Display Vehicle Count

This option has two parameters. Option 2.0 is used to turn the display of vehicle counts on the front panel mounted LCD **ON** and **OFF**. Option 2.1 is used to reset the vehicle count to zero.

The detector is capable of accumulating 99,999 vehicle counts before rolling over to zero. When Option 2.0 is **ON**, the normal display will show the accumulated vehicle count since the vehicle count was last reset. Setting Option 2.1 to ON resets the accumulated vehicle count. The setting of Option 2.1 automatically reverts to the **OFF** state when the parameter is exited. NOTE: Loss of power or resetting the detector will not reset the vehicle count.

2.8 Option 3 - Relay B Buzzer

When Option 3 is **ON**, an audible signal is emitted any time Relay B outputs a count, tailgating, or entry signal. Option 3 will automatically return to the **OFF** state 15 minutes after being set to **ON**.

2.9 Option 4 - Training Mode

When Option 4 is **ON**, the detector is placed in the training mode. This feature is used in conjunction with the Reno A&E Calibration Loop (not included with the detector) to ensure that the detector will accurately detect tailgating vehicles.

2.10 Option 5 - Relay B Output Mode

Option 5 is used to control the output mode of Relay B. Option 5 has seven (7) settings, 5.0 through 5.6. A setting of 5.0 is generally used in applications where the primary concern accurate counting of passenger vehicle entries. Option 5 settings 5.1 through 5.6 are used in applications where the primary concern is detection of events that are considered to be exceptions to normal entrance occurrences (i.e. tailgating or multiple passenger vehicle entry occurrences).

When Option 5 is set to 5.0, the detector's count total is incremented by one and Relay B provides a 0.25 second pulse count output for each passenger vehicle that passes over the loop.

Option 5 settings 5.1 through 5.3 are used in applications where the primary concern is detection of tailgating events. A tailgating incident occurs when two passenger vehicles are over the loop at the same time. When Option 5 is set to 5.1, 5.2, or 5.3 the detector's count total is incremented by one and Relay B provides a pulse output **only** when a tailgating incident has been detected. The duration of the pulse output varies depending on the setting of the option. When set to 5.1, the pulse duration is 0.25 second. When set to 5.2, the pulse duration is one second. When set to 5.3, the pulse duration is five seconds.

Option 5 settings 5.4 through 5.6 are used in applications where the primary concern is detection of multiple passenger vehicle entry events. Option 5 settings 5.4, 5.5, and 5.6 function in conjunction with Option 6 (see **Option 6 - Control Input Active High / Low** below). In a normal entrance scenario, one passenger vehicle enters the controlled area for each cycle of the control input. (In general, the control input is active when the gate is open and inactive when the gate is closed.) There are two different output schemes that can occur. The first occurs when Option 5 is set to 5.4, 5.5, or 5.6 and the state of the control input is active (i.e. the gate is open). The detector's count total is incremented by one and Relay B provides a pulse output for each passenger vehicle that crosses the loop **after** the first passenger vehicle has crossed the loop. Vehicle counts continue to be accumulated until the state of the control input changes (i.e. the gate closes). If the state of the control input is not active (i.e. the gate is closed), Option 5 settings 5.4, 5.5, and 5.6 result in a slightly different output scheme. The detector's count total is incremented by one and Relay B provides a pulse output for **every** passenger vehicle that crosses the loop. When set to Option 5.4 ON, the pulse duration is 0.25 second. When set to Option 5.5 ON, the pulse duration is one second. When set to Option 5.6 ON, the pulse duration is five seconds.

2.11 Option 6 - Control Input Active High / Low

When Option 6 is **OFF**, the control input is active when it is in a high state. When Option 6 is **ON**, the control input is active when it is not in a high state.

3.0 SPECIFICATIONS

3.1 Physical

WEIGHT: 24 oz. (680.4 gm).

SIZE: 4.70 inches (11.94 cm) high x 2.50 inches (6.35 cm) wide x 5.90 inches (14.99 cm) deep (excluding connector). Connector adds .675 inch (1.71 cm) to depth measurement.

OPERATING TEMPERATURE: -40° F to +180° F (-40° C to +82° C).

CIRCUIT BOARD: Printed circuit boards are 0.062 inch thick FR4 material with 2 oz. copper on both sides and plated through holes. Circuit board and components are conformal coated with polyurethane.

CONNECTOR: MS3102A-18-1P. See Section 3.6 for pin assignments.

3.2 Electrical

POWER: 89 to 135 VAC, 50/60 Hz, 6 Watts maximum (L-ATG-1). 180 to 270 VAC, 50/60 Hz, 6 Watts maximum (L-ATG-35). 10 to 30 VAC, 50/60 Hz, 6 Watts maximum / 10 to 30 VDC, 160 mA maximum (L-ATG-5).

CONTROL INPUT VOLTAGE: 89 to 135 VAC, 50/60 Hz, 6 Watts maximum (120 volt AC models). 180 to 270 VAC, 50/60 Hz, 6 Watts maximum (240 volt AC models). 10 to 30 VAC, 50/60 Hz, 6 Watts maximum / 10 to 30 VDC, 160 mA maximum (low voltage models).

LOOP INDUCTANCE RANGE: 20 to 2500 microhenries with a Q factor of 5 or greater.

LOOP INPUTS: Transformer isolated. The minimum capacitance added is 0.068 microfarad.

LIGHTNING PROTECTION: Meets and/or exceeds all applicable NEMA TS 1-1989 specifications for transient voltage protection.

RESET: When operating in Normal Mode, the detector can be reset by pressing and holding the **FUNC** pushbutton for three seconds. The detector can also be reset by removing and reapplying power, or by changing either the sensitivity or loop frequency setting. The vehicle count can only be reset by setting Option 2.1 to ON. A detector reset, changing the sensitivity or loop frequency, or loss of power will not reset the vehicle count.

RELAY RATING: The relay contacts are rated for 6 Amps maximum, 150 VDC maximum, and 180 Watts maximum switched power.

3.3 Operational

DISPLAY: The LCD backlighting illuminates whenever any pushbutton is pressed. The backlighting will extinguish 15 minutes after the last pushbutton press.

DETECT INDICATOR: The detector has a super bright, high intensity, red light emitting diode (LED) to indicate a Call Output, Delay Timing, Extension Timing, or Failed Loop condition.

RESPONSE TIME: (See Section 3.4 for actual response times.)

SELF-TUNING: The detector automatically tunes and is operational within two seconds after application of power or after being reset. Full sensitivity and hold time require 30 seconds of operation.

ENVIRONMENTAL & TRACKING: The detector is fully self-compensating for environmental changes and loop drift over the full temperature range and the entire loop inductance range.

GROUNDING LOOP OPERATION: The loop isolation transformer allows operation with poor quality loops (which may include one short to ground at a single point).

LOOP SIZE: The detector has been designed and tested to operate most effectively when connected to a single loop that measures 2.5 feet (0.76 m) x 6 feet (1.83 m) (nominal dimensions). **Connection to multiple loops is not recommended.** The loop size can vary from 2 feet (0.61 m) to 3 feet (0.91 m) in the direction of travel and 5 feet (1.52 m) to 7 feet (2.13 m) across the lane. The loop should have three (3), four (4), or five (5) turns of wire.

LOOP FEEDER LENGTH: Up to 5000 feet (1500 m) maximum with proper feeder cable and an appropriate loop.
NOTE: The detector has been designed and tested to operate most effectively when connected to a single loop that measures 2.5 feet x 6 feet. If the length of the loop feeder cable exceeds 200 feet (58 m), it may be necessary to increase the number of turns in the loop to ensure accurate vehicle counting.

LOOP (FAIL) MONITOR: If the total inductance of the detector's loop input network goes out of the range specified for the detector, or rapidly changes by more than $\pm 25\%$, the detector will immediately enter the Fail-Safe mode and display **LOOP FAIL** on the LCD. The type of loop failure will also be displayed as **L lo** (for -25% change or shorted loop conditions) or **L hi** (for $+25\%$ change or open loop conditions). This will continue as long as the loop fault exists. At the time of a loop failure, the LED will begin to flash at a rate of three flashes per second. The LED will continue this display pattern until the detector is manually reset or power is removed. If the loop self-heals, the **LOOP FAIL** message on the LCD will extinguish and the detector will resume operation in a normal manner; except the LED will continue the three flashes per second display pattern, thus providing an alert that a prior Loop Fail condition has occurred. Each loop failure for the detector is counted and accumulated into the Loop Fail Memory. The total number of loop failures written into the Loop Fail Memory (since the last power interruption or manual reset) is viewed by stepping through the functions in Program Mode until the **LOOP FAIL** message is displayed.

3.4 TABLE: Sensitivity, $-\Delta L/L$, & Response Times

Sensitivity	$-\Delta L/L$	Response Time
OFF	-----	-----
1	2.56%	96 \pm 16 ms
2	1.28%	96 \pm 16 ms
3	0.64%	96 \pm 16 ms
4	0.32%	96 \pm 16 ms
5	0.16%	96 \pm 16 ms
6	0.08%	96 \pm 16 ms
7	0.04%	96 \pm 16 ms
8	0.02%	96 \pm 16 ms
9	0.01%	96 \pm 16 ms
CALL	-----	-----

3.5 TABLE: Default Settings

Function	Setting
Loop Frequency	2
Sensitivity Level	5
Call Delay Time	0
Call Extension Time	0.0
Max Presence Time	OFF
Option 1 - Display Loop Inductance (L) and % Loop Inductance Change ($-\Delta L/L$)	OFF
Option 2.0 - Display Vehicle Count	OFF
Option 2.1 - Reset Vehicle Count	OFF
Option 3 - Relay B Buzzer	OFF
Option 4 Training Mode	OFF
Option 5 - Relay B Output Mode	5.0
Option 6 - Control Input Active High / Low	OFF

3.6 TABLE: Pin Assignments (Reno A&E Wiring Harness Model 801-4)

Pin	Wire Color	Function
A	White	AC Neutral / DC Common
B	Brown	Relay A, Normally Open (N.O.)
C	Black	AC Line / DC +
D	Red	Loop
E	Orange	Loop
F	Yellow	Relay A, Common
G	Blue	Control Input
H	Green	Chassis Ground
I	Violet	Relay B, Common
J	Gray	Relay B, Normally Open (N.O.)

NOTE: All pin connections listed above are with power applied, loop connected, and no vehicle detected.

4.0 USER INTERFACE

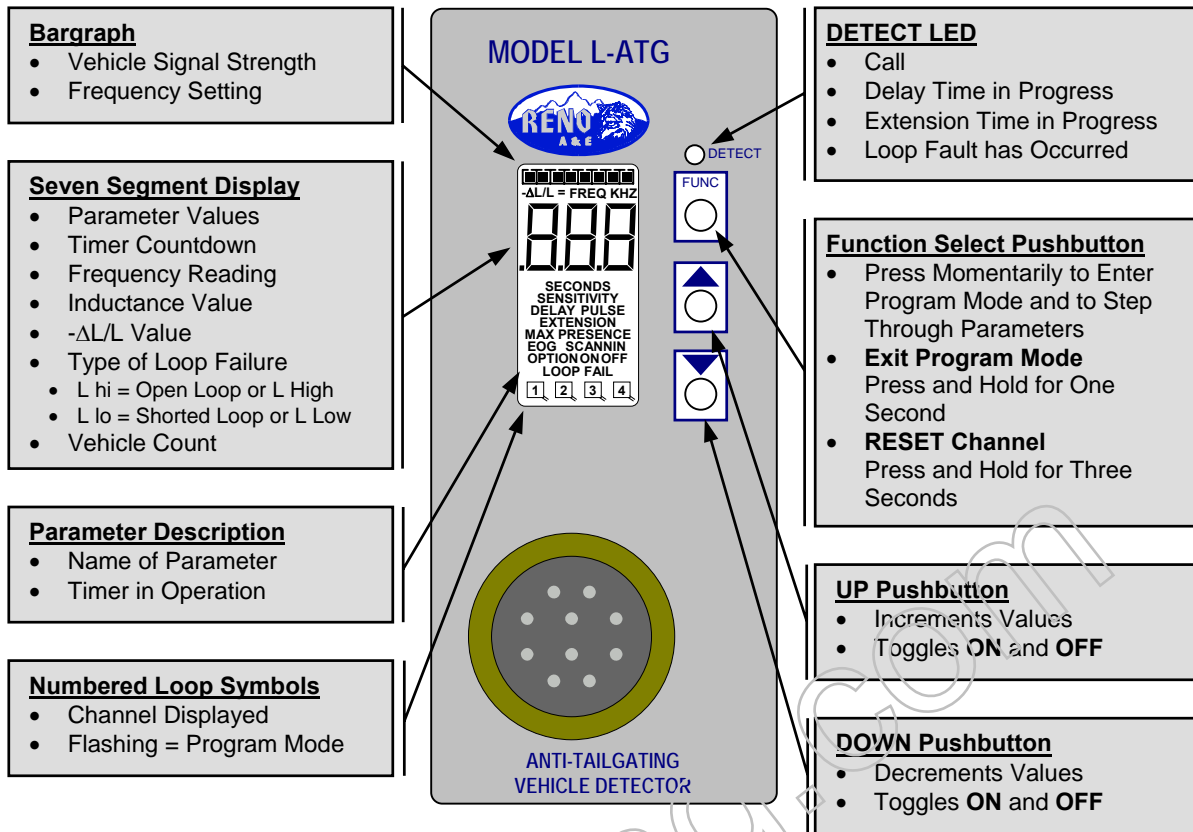

NOTE: There are no internal switches or jumpers to set.

5.0 INSTALLATION AND SET-UP

Prior to initial operation, the Model L-ATG detector must be calibrated. Connect the detector to an appropriately wired harness and apply power. Follow the instructions outlined in Section 5.3 to calibrate the detector.

The detector has no DIP switches or jumpers to configure. If the detector is not new from the factory, it may be advantageous to reset the detector back to the factory defaults to avoid having to check every setting. To reset the detector to factory default, press and hold all three pushbutton switches simultaneously for five seconds. When all three pushbuttons are depressed, the display will start counting down from five (5). When the countdown reaches zero (0), releasing the pushbuttons will reload the factory defaults and reset the detector. Once reset, the detector must be recalibrated as outlined in Section 5.3. NOTE: Resetting the detector back to factory defaults will not reset the vehicle count.

All operating parameters can be adjusted from the front panel. The detector continues to operate normally while it is in the Program Mode. The value currently displayed is always the actual value being used. Example: If you are changing the delay time, the time displayed at the instant that a vehicle entered the detection zone would be the value used for the delay timer.

Pressing the **FUNC** pushbutton enters the Program Mode. The **FUNC** pushbutton has an auto repeat function. This allows quick navigation to the desired parameter. The **FUNC** pushbutton only moves forward through all of the parameters. There is no way to move backwards through the parameters.

Pressing and holding either the ▲ (UP) or ▼ (DOWN) pushbutton will cause the value to change rapidly until the pushbutton is released.

Pressing and holding the **FUNC** pushbutton for one second will exit the Program Mode and return to the Normal Mode.

5.1 Program Mode Display Screens



PARAMETER Loop Frequency.
SETTINGS Eight (8) Selections - 1 to 8.
SETTING DISPLAYED Bargraph indicates settings from 1 (left) to 8 (right).
7 SEGMENT DISPLAY Actual Frequency of the loop circuit. Typically 20.0 to 99.9 kilohertz.
DEFAULT SETTING 2.
EXAMPLE Frequency setting 4 is selected. The loop frequency is 34.9 kHz.
NOTES Changing the frequency will reset the detector. An unstable frequency display varying more than ± 0.2 kilohertz may indicate loop crosstalk or other interference.

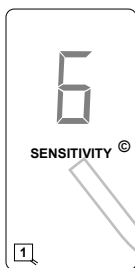

PARAMETER Sensitivity Level.
SETTINGS 11 Selections - 1 to 9, OFF, or CALL.
SETTING DISPLAYED 7-segment display will show the currently selected setting.
7 SEGMENT DISPLAY Currently selected Sensitivity Level.
DEFAULT SETTING 5.
EXAMPLE Sensitivity Level 6 is selected.
NOTES Changing the sensitivity will reset the detector. If the detector is in the call state when viewing this parameter, the bargraph will show the strength of vehicle calls so that the correct sensitivity can be verified from this screen.

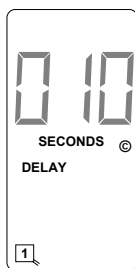

PARAMETER Call Delay Time.
SETTINGS 256 Selections - 0 to 255 Seconds in one-second steps.
SETTING DISPLAYED 7-segment display will show the currently selected setting.
7 SEGMENT DISPLAY Currently selected Delay time in seconds.
DEFAULT SETTING 0 seconds.
EXAMPLE Delay of 10 seconds selected
NOTES If the detection zone is occupied when this parameter is changed, the change will not take effect until the detection zone is empty or the detector is reset.



PARAMETER Call Extension Time.
SETTINGS 256 Selections - 0 to 25.5 Seconds in 0.1-second steps.
SETTING DISPLAYED 7-segment display will show the currently selected setting.
7 SEGMENT DISPLAY Currently selected Extension time in seconds.
DEFAULT SETTING 0 seconds.
EXAMPLE Extension of 2.5 seconds selected.
NOTES If the detection zone is occupied when this parameter is changed, the change will take effect while the detection zone is occupied.



PARAMETER Max Presence Time.
SETTINGS 1000 Selections - 1 second to 999 seconds or OFF.
SETTING DISPLAYED 7-segment display will show currently selected setting.
7 SEGMENT DISPLAY Currently selected Max Presence time in seconds.
DEFAULT SETTING OFF.
EXAMPLE Max Presence is turned OFF.
NOTES If the detection zone is occupied when this parameter is changed, the change will not take effect until the detection zone is empty or the detector is reset. When Max Presence is turned OFF, the detector operates in True Presence™ mode.

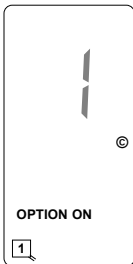

PARAMETER Option 1 (Display Loop / Lead-In Inductance, L and % Loop Inductance Change, $-\Delta L/L$).
SETTINGS ON or OFF.
SETTING DISPLAYED The word ON or OFF will be displayed.
7 SEGMENT DISPLAY The number of this option.
DEFAULT SETTING OFF.
EXAMPLE Option 1 is turned ON.
NOTES This option will automatically turn off 15 minutes after being activated or on loss of power.



PARAMETER Option 2.0 (Display Vehicle Count).
SETTINGS ON or OFF.
SETTING DISPLAYED The word ON or OFF will be displayed.
7 SEGMENT DISPLAY The number of this option.
DEFAULT SETTING OFF.
EXAMPLE Option 2.0 is turned OFF.
NOTES When this option 2.0 is ON, the Normal Mode display will show the accumulated vehicle count since the vehicle count was last reset. The display will show the hundreds, tens, and ones digits until the accumulated count exceeds 999. At this point the display will alternate between the ten thousands and thousands digits and the remaining three digits for hundreds, tens, and ones. The unit is capable of accumulating 99,999 vehicle counts before rolling over to zero.



PARAMETER Option 2.1 (Reset Vehicle Count).
SETTINGS ON or OFF.
SETTING DISPLAYED The word ON or OFF will be displayed.
7 SEGMENT DISPLAY The number of this option.
DEFAULT SETTING OFF.
EXAMPLE Option 2.1 is turned ON.
NOTES Setting Option 2.1 to ON resets the accumulated vehicle count. The setting of Option 2.1 automatically reverts to the OFF state when the parameter is exited.

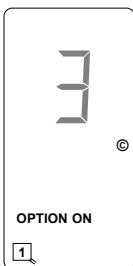

PARAMETER Option 3 (Relay B Buzzer).
SETTINGS ON or OFF.
SETTING DISPLAYED The word ON or OFF will be displayed.
7 SEGMENT DISPLAY The number of this option.
DEFAULT SETTING OFF.
EXAMPLE Option 3 is turned ON.
NOTES When Option 3 is ON, an audible signal is emitted any time Relay B outputs a count, tailgating, or entry signal. This option will automatically turn off 15 minutes after being activated or on loss of power.

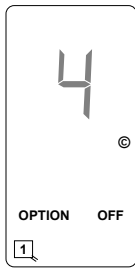

PARAMETER Option 4 (Training Mode).
SETTINGS ON or OFF.
SETTING DISPLAYED The word ON or OFF will be displayed.
7 SEGMENT DISPLAY The number of this option.
DEFAULT SETTING OFF.
EXAMPLE Option 4 is turned OFF.
NOTES *Refer to Section 5.3 for a complete explanation of this option.*



PARAMETER Option 5 (Relay B Output Mode).
SETTINGS Seven selections: 5.0 to 5.6.
SETTING DISPLAYED The word ON or OFF will be displayed.
7-SEGMENT DISPLAY The number of this option.
DEFAULT SETTING 5.0.
EXAMPLE Option 5.0 is turned ON.
NOTES *Refer to Section 5.4 for a complete explanation of this option.*

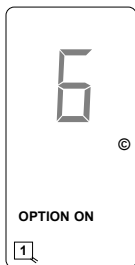

PARAMETER Option 6 (Control Input Active High / Low).
SETTINGS ON or OFF.
SETTING DISPLAYED The word ON or OFF will be displayed.
7 SEGMENT DISPLAY The number of this option.
DEFAULT SETTING OFF.
EXAMPLE Option 6 is turned ON.
NOTES When Option 6 is ON, the control input is active when it is not in a state. When Option 6 is OFF, the control input is active when it is in a high state.



PARAMETER Loop Fail.
SETTINGS Pressing the ▲ (UP) or ▼ (DOWN) pushbutton will clear the Loop Fail memory.
SETTING DISPLAYED View only.
7 SEGMENT DISPLAY Loop Failures since the last time it was cleared manually or due to power failure.
DEFAULT SETTING 0.
EXAMPLE There are eight (8) Loop Failures in the accumulator.
NOTES Count will be reset to zero after loss of power, by pressing the ▲ (UP) or ▼ (DOWN) pushbutton, or by resetting the detector.

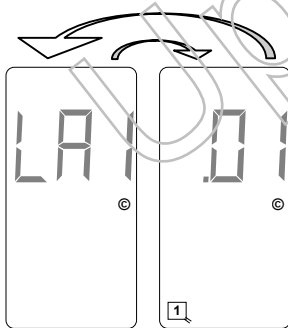

PARAMETER Firmware Version and Revision.
SETTINGS View Only.
SETTING DISPLAYED View Only.
7 SEGMENT DISPLAY Model letter and firmware version on one screen and firmware revision on the other screen.
DEFAULT SETTING Not Applicable.
EXAMPLE Model L-ATG firmware version 1, revision .01.

5.2 Normal Mode Display Screens

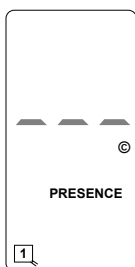

STATE Idle.
BARGRAPH DISPLAY OFF.
7 SEGMENT DISPLAY Three Dashes.
TEXT PRESENCE indicating detection mode of the detector.
DETECT LED OFF.
DETECTOR OUTPUTS OFF.
EXAMPLE The detector is idle and in the presence mode of detection.
NOTES This is the normal state for the display when the loop detection zone is unoccupied and the detector does not have any timing options set.



STATE Presence Call.
BARGRAPH DISPLAY Number of sensitivity levels that the inductance change caused by the vehicle exceeds the detection threshold (first dot = current sensitivity level, second dot = next lower sensitivity level, etc.).
7 SEGMENT DISPLAY Call.
TEXT PRESENCE, indicating detection mode of the detector.
DETECT LED Solid ON.
DETECTOR OUTPUTS ON.
EXAMPLE The detection zone is occupied by a vehicle that exceeds the detection threshold by four (4) sensitivity levels and the detector is outputting a call.



STATE Timing Delay.
BARGRAPH DISPLAY Number of sensitivity levels that the inductance change caused by the vehicle exceeds the detection threshold (first dot = current sensitivity level, second dot = next lower sensitivity level, etc.).
7 SEGMENT DISPLAY Countdown of remaining Delay time (in seconds).
TEXT SECONDS, DELAY, and PRESENCE.
DETECT LED Four Hz flash rate with 50% duty cycle (125 ms ON, 125 ms OFF).
DETECTOR OUTPUTS OFF.
EXAMPLE The detection zone is occupied by a vehicle that exceeds the detection threshold by two (2) sensitivity levels, there are three (3) seconds of Delay time remaining, and the detector is not outputting a call.



STATE Timing Extension.
BARGRAPH DISPLAY OFF.
7 SEGMENT DISPLAY Countdown of remaining Extension time (in seconds).
TEXT SECONDS, EXTENSION, and PRESENCE.
DETECT LED 16.6 Hz flash rate with 50% duty cycle (30 ms ON, 30 ms OFF).
DETECTOR OUTPUTS ON.
EXAMPLE The detection zone is vacant, there are two and one-half (2.5) seconds of Extension time remaining, and detector is outputting a call.



STATE Timing Max Presence.
BARGRAPH DISPLAY Number of sensitivity levels that the inductance change caused by the vehicle exceeds the detection threshold (first dot = current sensitivity level, second dot = next lower sensitivity level, etc.).
7 SEGMENT DISPLAY Countdown of remaining seconds of Max Presence.
TEXT SECONDS and MAX PRESENCE.
DETECT LED Solid ON.
DETECTOR OUTPUTS ON.
EXAMPLE The detection zone is occupied by a vehicle that exceeds the detection threshold by five (5) sensitivity levels, there are 30 seconds of Max Presence remaining, and the detector is outputting a call.



STATE Loop Inductance (L) Display (Option 1 ON).
BARGRAPH DISPLAY OFF.
7 SEGMENT DISPLAY Loop / Lead-In circuit inductance in microhenries. If the value exceeds 999, the display will alternate between the thousands place (1 or 2) and the lower three digits of the inductance value.
TEXT L =.
DETECT LED The detect LED operates normally indicating call, no call, delay, and/or extension as expected.
DETECTOR OUTPUTS The detector outputs operate normally.
EXAMPLE The Loop / Lead-In circuit inductance is 98 microhenries and the detector is not detecting a vehicle.
NOTES If Option 1 (L and -ΔL/L Display) is ON, this display is only visible when the detector is not detecting a vehicle.



STATE % Loop Inductance Change (-ΔL/L) Display (Option 1 ON).

BARGRAPH DISPLAY OFF if no vehicle is detected. Number of sensitivity levels that the inductance change caused by the vehicle exceeds the detection threshold (first dot = current sensitivity level, second dot = next lower sensitivity level, etc.) if a vehicle is detected.

7 SEGMENT DISPLAY Percentage of change in inductance of the Loop / Lead-In circuit.

TEXT -ΔL/L =.

DETECT LED The detect LED operates normally indicating call, no call, delay, and/or extension as expected.

DETECTOR OUTPUTS The detector outputs operate normally.

EXAMPLE Percentage change of inductance of the call is 10.7% and the detection zone is occupied by a vehicle that exceeds the detection threshold by six (6) sensitivity levels.



STATE % Loop Inductance Change (-ΔL/L) Display (Option 1 ON).

BARGRAPH DISPLAY OFF if no vehicle is detected. Number of sensitivity levels that the inductance change caused by the vehicle exceeds the detection threshold (first dot = current sensitivity level, second dot = next lower sensitivity level, etc.) if a vehicle is detected.

7 SEGMENT DISPLAY Percentage of change in inductance of the Loop / Lead-In circuit.

TEXT -ΔL/L =.

DETECT LED The detect LED operates normally indicating call, no call, delay, and/or extension as expected.

DETECTOR OUTPUTS The detector outputs operate normally.

EXAMPLE Percentage change of inductance of the last call was 10.7% and the detection zone is vacant.

NOTES If Option 1 (L and -ΔL/L Display) is ON, this display is visible for the two seconds following the end of a vehicle detection.

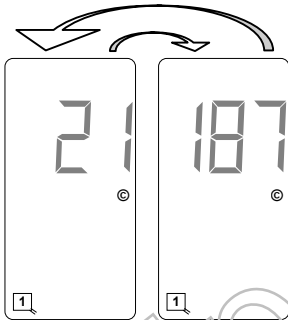

STATE Accumulated Vehicle Count Display (Option 2.0 ON).

BARGRAPH DISPLAY OFF if no vehicle is detected. Number of sensitivity levels that the inductance change caused by the vehicle exceeds the detection threshold (first dot = current sensitivity level, second dot = next lower sensitivity level, etc.) if a vehicle is detected.

7 SEGMENT DISPLAY The accumulated vehicle count.

TEXT None.

DETECT LED The detect LED operates normally indicating call, no call, delay, and/or extension as expected.

DETECTOR OUTPUTS The detector outputs operate normally.

EXAMPLE The accumulated vehicle count is 21,187.

NOTES The display alternates between the upper two digits and the lower three digits. If the upper two digits are zero (i.e. the count has not exceeded 999), they are not displayed at all and only the lower three digits will be displayed.



STATE LCD Test.

BARGRAPH DISPLAY All segments on.

7 SEGMENT DISPLAY All segments on.

TEXT All segments on.

DETECT LED The detect LED operates normally indicating call, no call, delay and/or extension as expected.

DETECTOR OUTPUT The detector output operates normally.

EXAMPLE All segments on.

NOTES This display is visible whenever any two pushbutton switches are pressed at the same time.

5.3 Option 4 - Training Mode

When Option 4 is turned **ON**, the detector is placed in the Training Mode. To train the detector, turn Option 4 **ON**. The LCD will display **CAL**. Place the Reno A&E Calibration Loop (not included with the detector) on the ground at least two feet away from the inductive loop and slowly drag the calibration loop through the center of the lane making sure that the loop passes over the center of inductive loop. The training process takes approximately five (5) seconds. Once the training process has been successfully completed, the display will revert from **CAL** to Option 4 **OFF**. Please note that once the training process has been initiated, the only way to abort the process is to cycle power to the detector. The factory default setting of Option 4 is **OFF**. **NOTE: Proper training is essential for accurate detection of tailgating vehicles. It is critical that cars or other vehicles do not pass over the inductive loop while training is in progress.**

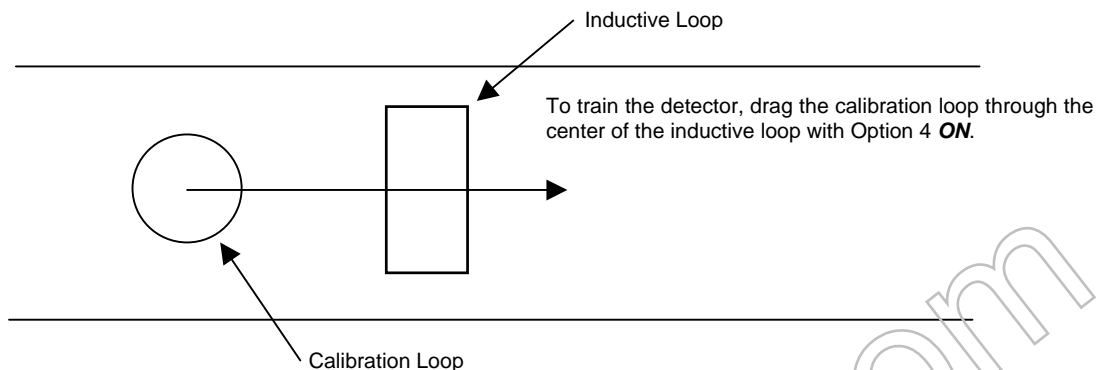

5.4 Option 5 - Relay B Output Mode

Option 5 is used to control the output mode of Relay B. Option 5 has seven (7) settings, 5.0 through 5.6. A setting of 5.0 is generally used in applications where the primary concern accurate counting of passenger vehicle entries. Option 5 settings 5.1 through 5.6 are used in applications where the primary concern is detection of events that are considered to be exceptions to normal entrance occurrences (tailgating or multiple passenger vehicle entry occurrences).

When Option 5 is set to 5.0, the detector's count total is incremented by one and Relay B provides a 0.25 second pulse count output when a passenger vehicle entry has been detected.

Option 5 settings 5.1 through 5.3 are used in applications where the primary concern is detection of tailgating events. When Option 5 is set to 5.1, 5.2, or 5.3 the detector's count total is incremented by one and Relay B provides a pulse output **only** when a tailgating incident has been detected. A tailgating incident occurs when two passenger vehicles are over the loop at the same time. The duration of the pulse output varies depending on the setting of the option. When set to 5.1, the pulse duration is 0.25 second. When set to 5.2, the pulse duration is one second. When set to 5.3, the pulse duration is five seconds.

Option 5 settings 5.4 through 5.6 are used in applications where the primary concern is detection of multiple passenger vehicle entry events. In a normal entrance scenario, one passenger vehicle enters the controlled area for each cycle of the control input. (In general, the control input is active when the gate is open and inactive when the gate is closed.)

There are two different output schemes that can occur. The first occurs when Option 5 is set to 5.4, 5.5, or 5.6 and the state of the control input is active (i.e. the gate is open). The detector's count total is incremented by one and Relay B provides a pulse output for each passenger vehicle that crosses the loop **after** the first passenger vehicle has crossed the loop. Vehicle counts continue to be accumulated until the state of the control input changes (i.e. the gate closes). As an example, this scenario would occur when a legitimate entry (by the first passenger vehicle) is followed by one or more additional passenger vehicles entering the controlled area before the gate has closed. The passenger vehicle(s) following the first passenger vehicle would be counted and identified by the pulse output which could be used to trigger a camera or some other form of recording equipment.

If the state of the control input is not active (i.e. the gate is closed), Option 5 settings 5.4, 5.5, and 5.6 result in a slightly different output scheme. The detector's count total is incremented by one and Relay B provides a pulse output for **every** passenger vehicle that crosses the loop. This scenario would occur when a one or more passenger vehicles enter the controlled area when the gate arm has been broken off. The passenger vehicle(s) entering would be counted and identified by the pulse output which could be used to trigger a camera or some other form of recording equipment.

When set to 5.4, the pulse duration is 0.25 second. When set to 5.5, the pulse duration is one second. When set to 5.6, the pulse duration is five seconds.

The factory default setting of Option 5 is 5.0.

Option 5 Setting	Control Input State	Relay B Output	Relay B Output Duration
5.0	N/A	With Vehicle Entry	0.25 Second
5.1	N/A	With Tailgating Incident	0.25 Second
5.2	N/A	With Tailgating Incident	1 Second
5.3	N/A	With Tailgating Incident	5 Seconds
5.4	Active	With Vehicle Entry Following Lead Vehicle Entry	0.25 Second
5.4	Not Active	With Vehicle Entry	0.25 Second
5.5	Active	With Vehicle Entry Following Lead Vehicle Entry	1 Second
5.5	Not Active	With Vehicle Entry	1 Second
5.6	Active	With Vehicle Entry Following Lead Vehicle Entry	5 Seconds
5.6	Not Active	With Vehicle Entry	5 Seconds

The timing charts that follow illustrate the various Option 5 settings and the output states of the two relays.

Option 5 Settings 5.0, 5.1, 5.2, and 5.3

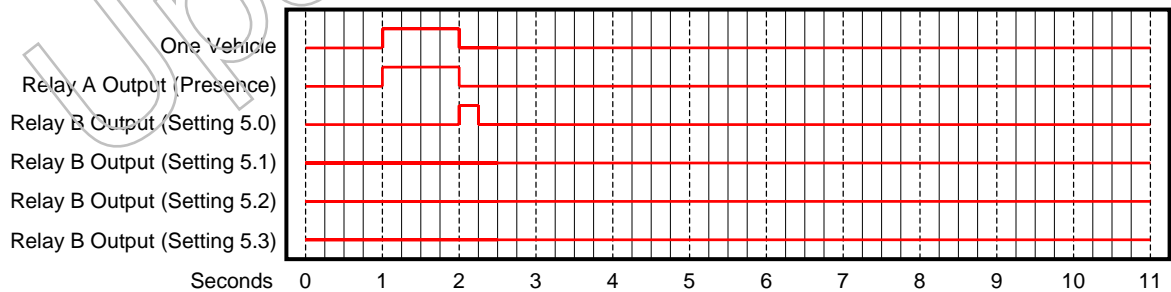
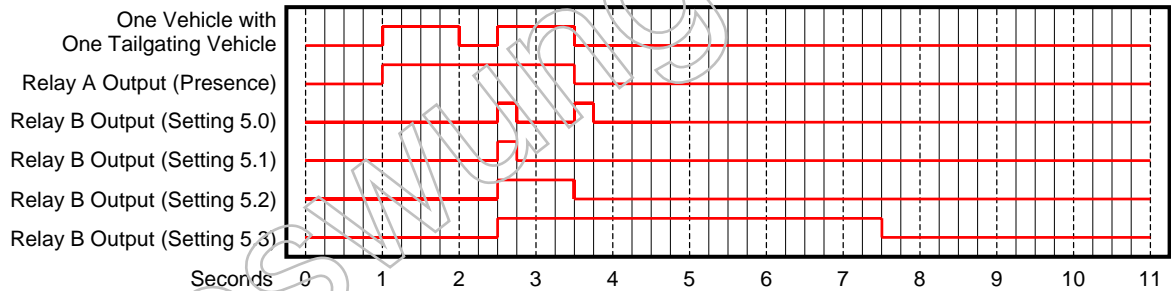
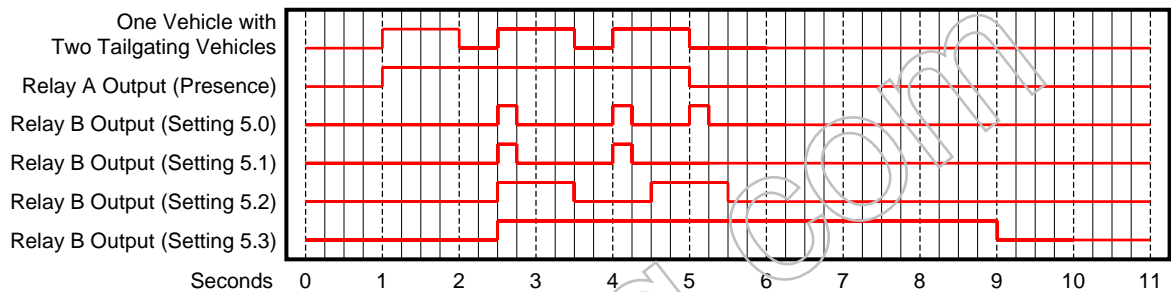

Option 5 Settings 5.4, 5.5, and 5.6 (Control Input Active)

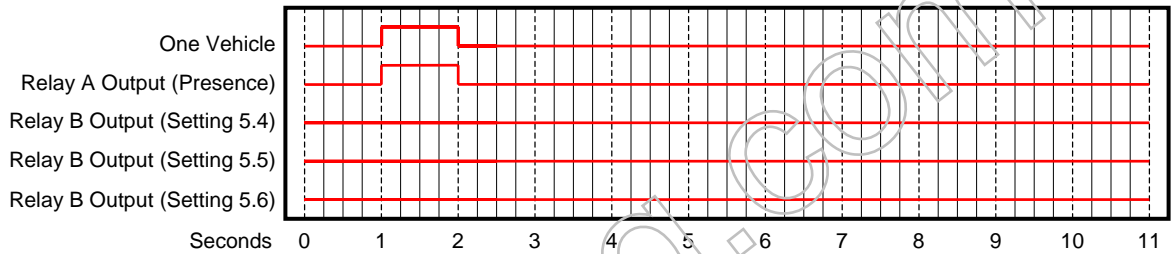
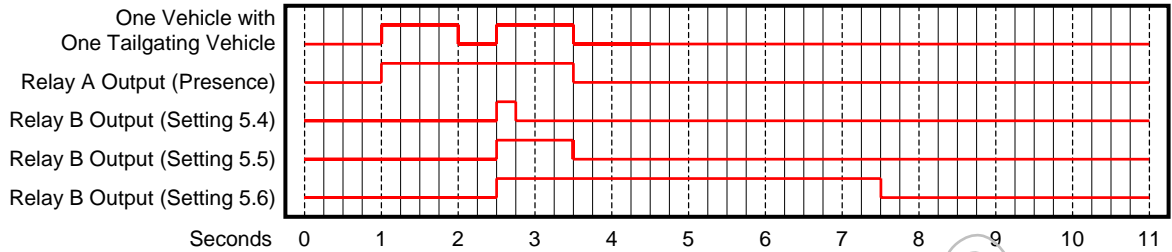
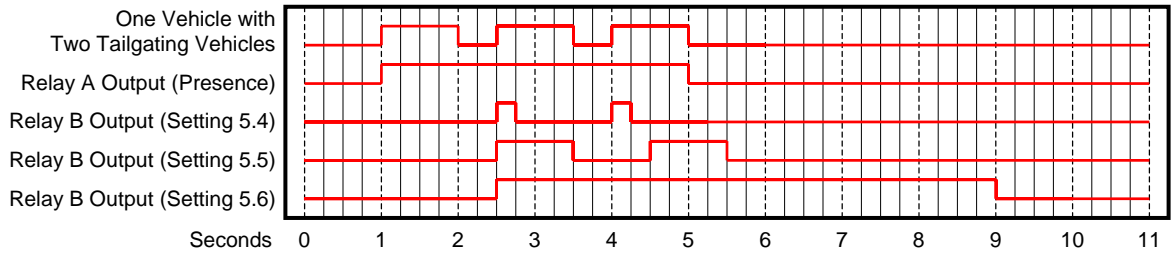

Option 5 Settings 5.4, 5.5, and 5.6 (Control Input Not Active)

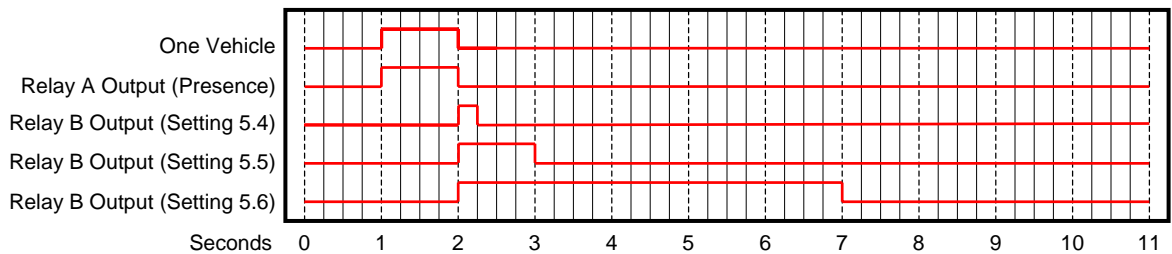
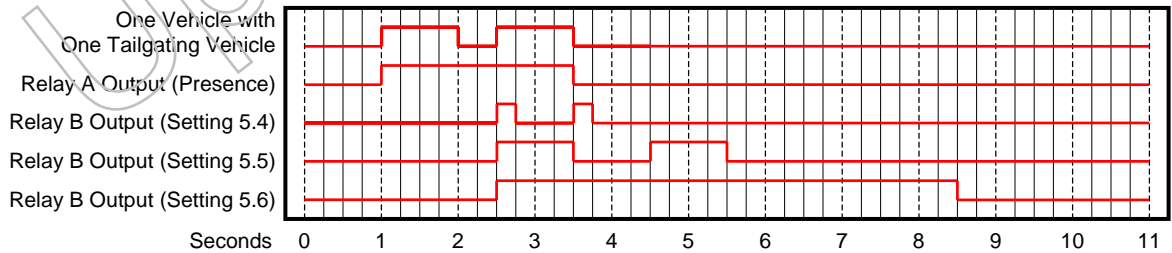
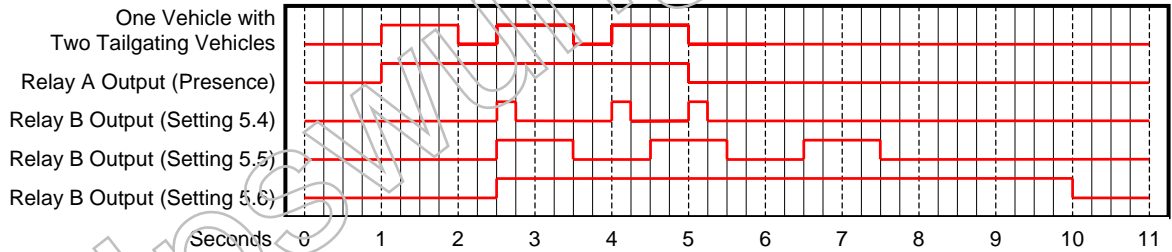

5.5 Option 6 - Control Input Active High / Low

When Option 6 is **OFF**, the control input is active when it is in a high state. When Option 6 is **ON**, the control input is active when it is not in a high state. **NOTE: Proper detector operation requires that the control input is active when the gate or barrier is open.**

5.6 Loop Fail Indications

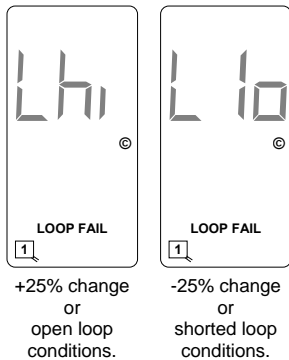

If the total inductance of the loop input network goes out of the range specified for the detector, or rapidly changes by more than $\pm 25\%$, the detector will enter the Fail-Safe mode and **LOOP FAIL** will be displayed on the LCD. The type of loop failure will also be displayed as **L lo** (for -25% change or shorted loop conditions) or **L hi** (for $+25\%$ change or open loop conditions). This will continue as long as the loop fault exists. Fail-Safe mode generates a continuous call. At the time of a loop failure, the detect LED will begin to flash at a rate of three flashes per second. The LED will continue this display pattern until the detector is manually reset or power is removed.

If the loop self-heals, the **LOOP FAIL** message on the LCD will extinguish and the detector will resume operation in a normal manner, except, the LED will continue the three flashes per second display pattern, thus, providing an alert that a prior Loop Fail condition has occurred. Each loop failure is counted and accumulated into the Loop Fail Memory. The total number of loop failures for the detector is written into the Loop Fail Memory (since the last power interruption or manual reset) and can be seen by stepping through the functions in Program Mode to the **LOOP FAIL** display.

This is a useful tool to identify intermittent loop problems. If the count is extremely high for the period of time observed, the problem is very likely a loose connection (check for loose connections at the terminal strip and bad splices in the field). The Loop Fail Count is reset when power is removed from the detector. This prevents the Loop Failure Count from moving to another loop, if the detector is moved to a new location.

To view the Loop Fail Count, repeatedly press the **FUNC** pushbutton until the **LOOP FAIL** display is shown. The Loop Fail Count display is after the **OPTION** displays. Pressing the **▲** (UP) or **▼** (DOWN) pushbutton while the Loop Fail Count is displayed will reset the count to zero.

NOTE: The Loop Fail Count is not reset when the detector's sensitivity or frequency is changed. The prior Loop Fail indication will continue until the Loop Fail Count is reset to zero.

5.7 Setting Sensitivity Using the Bargraph

The bargraph is a graphical representation of the relative change of inductance as seen by the detector. It automatically takes into account the detector's sensitivity setting, loop geometry, configuration, lead-in length, etc. The first bar segment represents the minimum inductance change (set by the sensitivity level) necessary for the detector to output a call. Each additional segment to the right represents the inductance change in excess of the next sensitivity threshold. Usually, the larger the vehicle, the greater the $-\Delta L/L$; thus, more and more segments are displayed. The bargraph can be used as a precise indicator to select the proper sensitivity level.

The bargraph below shows the deflection (3 segments) of a vehicle with Sensitivity set to Level 4. The vehicle in the loop zone is causing a change of inductance greater than $1.28\% -\Delta L/L$ or Sensitivity Level 2.

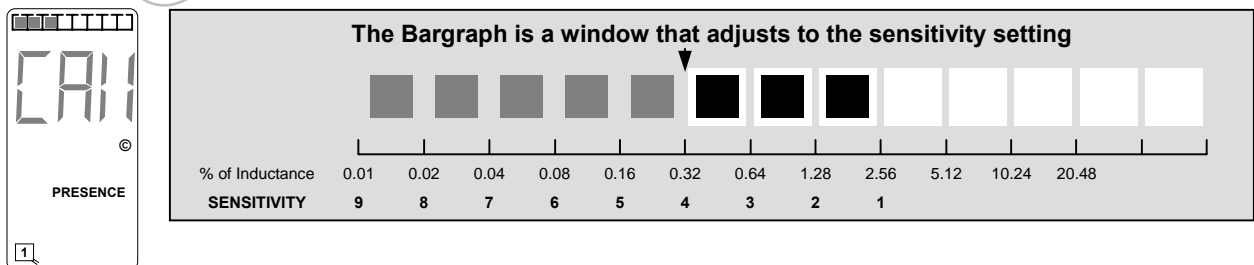

The bargraph below has the same vehicle in the loop zone causing the same inductance change as above. Since the sensitivity setting was increased to Level 7, six segments are now displayed. If the bargraph displays 5 or 6 segments for a vehicle in the loop and motorcycles are not a concern, the sensitivity has been set to the proper range.

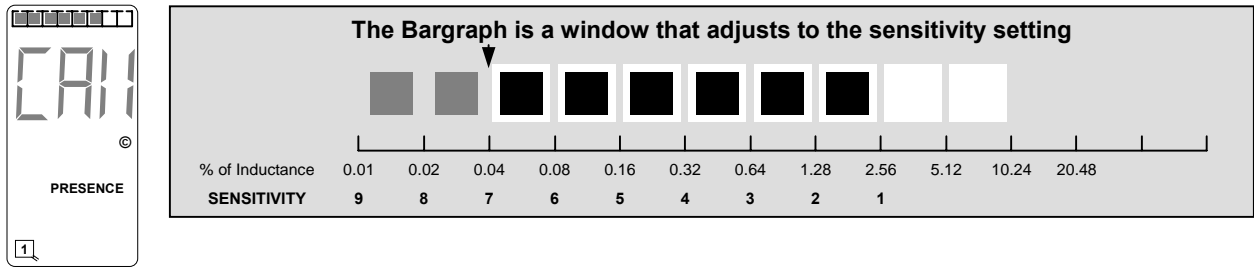

5.8 Setting Sensitivity for Motorcycle Detection Using the Bargraph

The bargraph can also be used to select the proper sensitivity level for small motorcycle detection. The relative change of inductance caused by a motorcycle and a single automobile are proportional on any loop configuration. Selecting the sensitivity level that causes the bargraph to display the seventh segment for a single standard automobile automatically sets the sensitivity to detect small motorcycles. Follow the steps below:

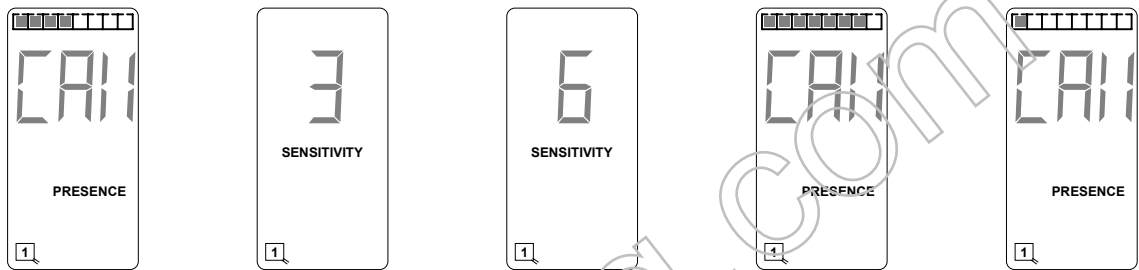

Step 1: Observe a single standard automobile in the loop zone. Note the number of segments displayed on the bargraph. (4)

Step 2: Go to the Program mode. Note the sensitivity level. (3)

Step 3: Subtract the actual number of segments displayed from the desired number of 7. (7 - 4 = 3) increase the sensitivity three levels.

Step 4: Verify that a single standard automobile causes the bargraph to move seven segments.

Step 5: A small motorcycle should be detected causing a one segment deflection.

NOTE: This method applies to conventional loop configurations only. Other loop configurations, such as Quadrupole, will require a different method to correctly set sensitivity for motorcycle detection. Increasing the sensitivity to detect motorcycles in some loop configurations will make the loop sensitive to adjacent lane detection. If adjacent lane traffic is detected, the phase will max time when no vehicles are present in the loop (see Option 5 - Phase Green Loop Compensation for a possible solution).

5.9 Full Restore To Factory Default Settings

Pressing all three front panel pushbutton switches simultaneously and continuously for five (5) seconds resets the detector and restores all the factory default settings. The countdown of the five second period is displayed on the LCD. Releasing any of the switches before the countdown ends aborts the Full Restore operation. (See Section 3.5 for default settings.) **NOTE: Following a factory default reset, the detector must be recalibrated. Refer to Section 5.3 Option 4 - Training Mode for details.**

5.10 Display Test

Pressing any two of the front panel pushbutton switches simultaneously will turn on all possible symbols and messages on the LCD.

6.0 BLOCK DIAGRAM

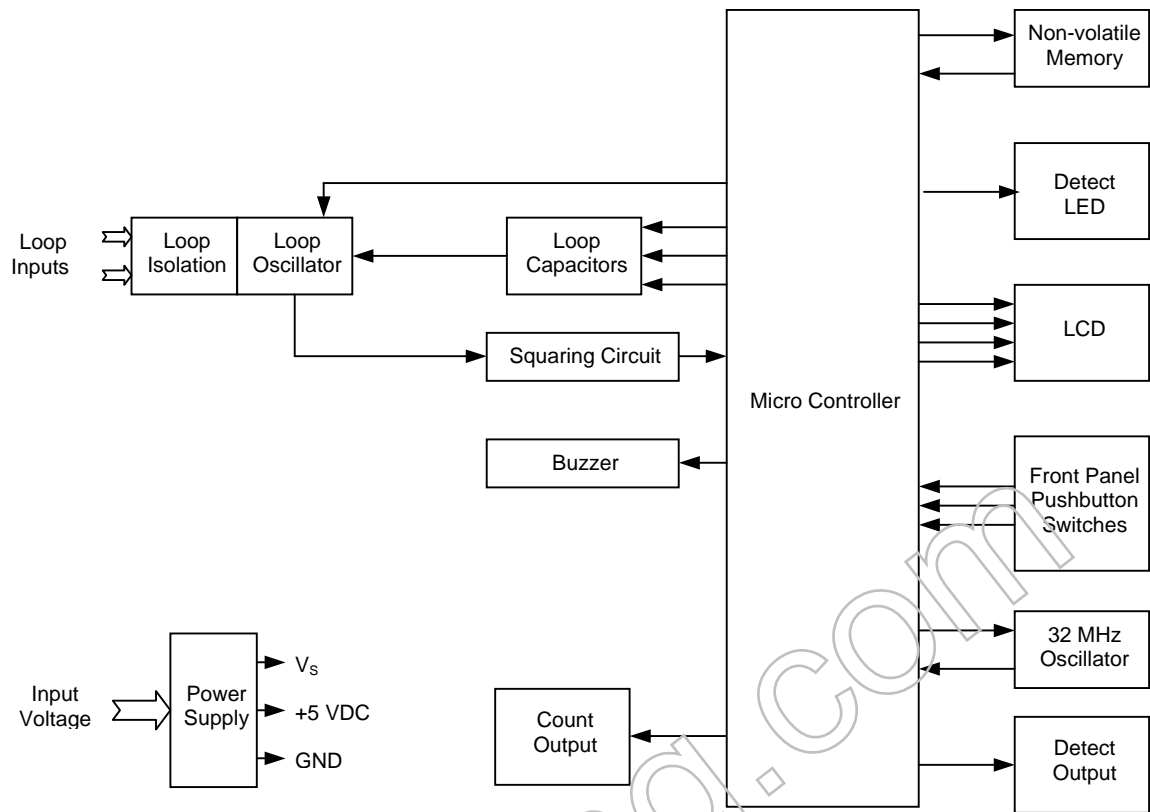

7.0 THEORY OF OPERATION

The Reno A&E Model L-ATG detector digitally measures changes in the resonant frequency of the loop circuit to determine if a vehicle has entered the detection zone. The Model L-ATG Series detector applies an excitation voltage to the loop circuit resulting in the loop oscillating at its resonant frequency. The current flow in the loop wire creates magnetic fields around the loop wire. When a vehicle passes over the loop area, the conductive metal of the vehicle causes a loading of the loop's magnetic fields. The loading decreases the loop inductance, which causes the resonant frequency to increase. By continuously sampling the loop's resonant frequency, the magnitude and rate of change can be determined. If the frequency change exceeds a selectable threshold (set by the sensitivity settings), the detector will activate an output signal. If the rate of change is slow, typical of environmental drift, the detector will continuously track and compensate for the change. The Model L-ATG detector also monitors the loop frequency for out of range conditions such as an open or shorted loop circuit.

The detector's oscillator circuit supplies an excitation voltage that is coupled to the loop circuit by a loop isolation transformer. The transformer provides high common mode isolation between the loop and detector electronics, which allows the detector to operate on poor quality loops including a single short to ground. The transformer also limits the amount of static energy (lightning) that can transfer to the detector electronics. A spark gap transient suppression device is connected across the loop inputs connected to the isolation transformer. This device dissipates static charges before they reach the transformer. A network of four capacitors is connected to the detector side of the isolation transformer. Three of the capacitors can be switched in or out of the oscillator circuit to shift the frequency of the loop oscillator circuit thus providing frequency separation between adjacent loops. The three switchable capacitors are electronically switched using FETs and are selected when programming parameter values with the front panel pushbutton switches.

The output from the loop oscillator is fed into a squaring circuit. The sine wave from the loop oscillator circuit is squared to provide a precise zero crossing signal for the input to the microcontroller. This signal is called the loop sample. The loop sample is an integral number of complete oscillations from the loop oscillator circuit. The number of loop oscillations counted is a function of the selected sensitivity setting for the detector. The required number of loop oscillations needed for a loop sample increases as the sensitivity setting is increased. The microcontroller uses the period of the loop sample for accumulating high-speed (32 MHz) crystal clock pulses generated by the microcontroller's internal high-speed crystal oscillator. The number of crystal clock pulses accumulated during consecutive loop samples is compared to the internal reference number of crystal clock pulses stored in the microcontroller's memory.

When a vehicle enters the loop zone the loop inductance decreases. This decrease in loop inductance causes an increase in the loop oscillator frequency. In turn, an increase in loop oscillator frequency results in a decrease of the time period for the loop sample. Hence, when a vehicle enters the loop zone the number of crystal clock pulses accumulated during a loop sample period decreases. By comparing the new count with the reference count, a percentage change can be calculated that indirectly relates to the inductance change. If the magnitude of the change exceeds a selectable threshold (sensitivity setting), the detector activates an output device. The rate of change is also monitored. Slow rates of change caused by environmental fluctuations are tracked and automatically compensated for.

The microcontroller uses the high-speed crystal clock count to calculate the loop inductance, frequency and percentage of change. If selected, the values are displayed on the seven segment LCD. The microcontroller also processes the pushbutton switch selections for the LCD and stores the operating parameters in non-volatile memory. Stored parameters are only changed with the front panel switches and are unaffected by loss of power or detector reset. The microcontroller continuously processes the loop samples and the detector operation is not affected during the operation of the switches or the LCD. (NOTE: When either sensitivity or frequency is changed, the detector is reset.)

In addition, the microcontroller conditions the outputs based on the programmed settings of the various timers (Delay, Extension, and Max Presence) and options (Option 3, Option 5, and Option 6).

8.0 MAINTENANCE AND TROUBLESHOOTING

The Reno A&E Model L-ATG Detector requires no maintenance. If you are having problems with your Model L-ATG detector, use the troubleshooting chart below to help determine the cause of the problem.

Symptom	Where To Start
No LCD display and LED not lit.	See <i>Troubleshooting Power Problems</i> .
LCD displays garbage and detector does not respond to pushbutton presses.	See <i>Troubleshooting Initialization Problems</i> .
Detector does not respond to pushbutton presses.	See <i>Troubleshooting Initialization Problems</i> .
LCD continually displays L lo and LOOP FAIL or L hi and LOOP FAIL .	See <i>Troubleshooting Loop Fail Problems</i> .
The detect LED is flashing three times per second and detector appears to be working correctly.	See <i>Troubleshooting Intermittent Loop Fail Problems</i> .
Detector intermittently stays in the Call state.	See <i>Troubleshooting Intermittent Detector Lock Ups</i> .
LCD always displays a flashing CALL .	The sensitivity has been set to Call forcing the detector to output a constant call.

8.1 Troubleshooting Power Problems

Does the LCD display anything when the detector is powered up?

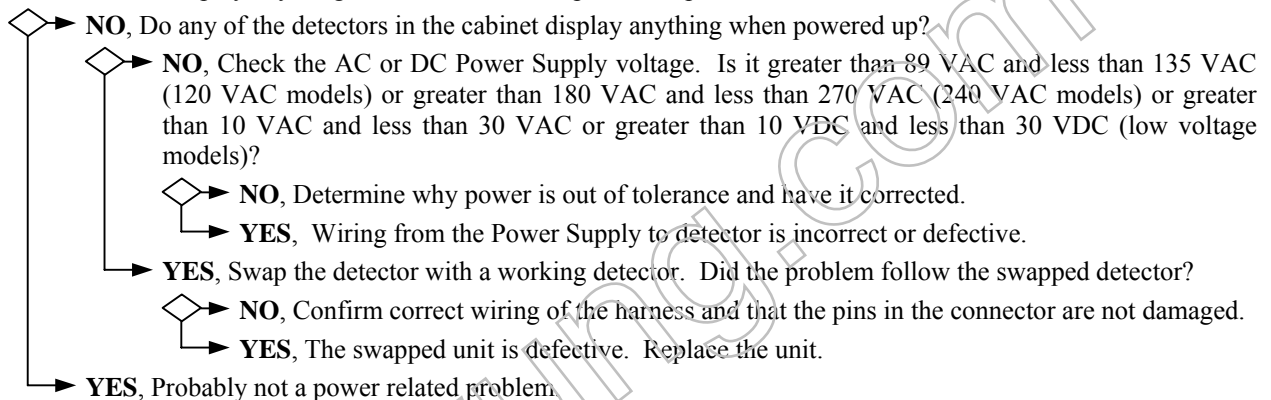

8.2 Troubleshooting Initialization Problems

Does the LCD display the Model and Firmware version when powered up?

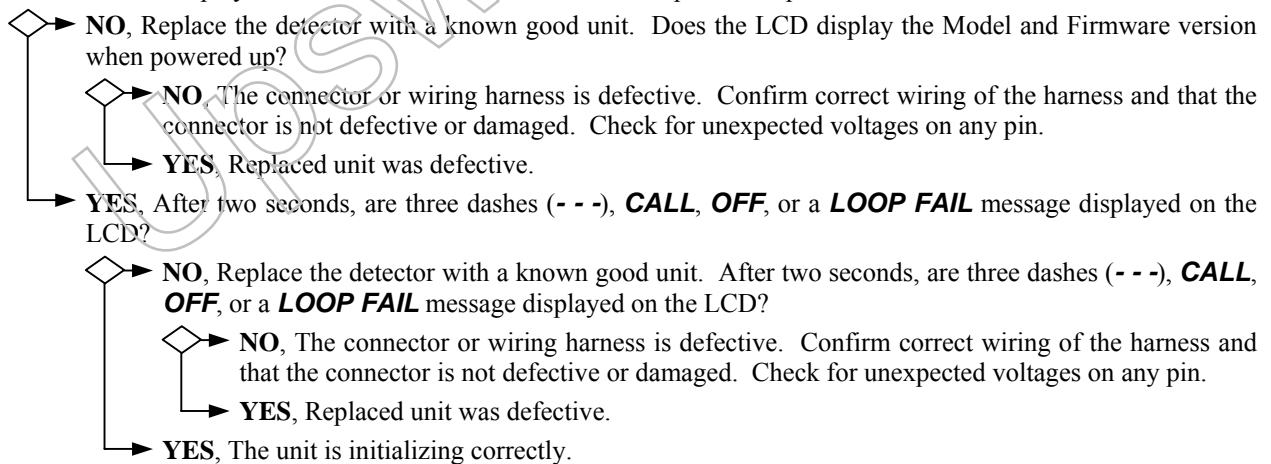

8.4 Troubleshooting Intermittent Loop Fail Problems

Have you been able to see the detector display while the loop failure was occurring?

◇ → **NO**, Loop Fail problems tend to be bad splices in the loop / lead-in circuit, shorts in the loop / lead-in circuit, shorts to earth ground in the loop / lead-in circuit, or loose connections or bad solder joints in the signal cabinet. If you have any splices that are not soldered and sealed with an adhesive heat shrink or epoxy resin, replace the splice with one that is. Using a MegOhm meter, measure the resistance from one of the loop wires to earth ground. It should be greater than 50 megOhms. Inspect the loop. Look for exposed wires or debris pressed into the saw cut. Tighten all screw terminals in the signal cabinet that the loop circuit uses. Check solder joints in the loop circuit, especially on the harness itself. Disconnect and reconnect any connector used in the loop circuit and check for loose pins and sockets in these connectors. If your cabinet has lightning or surge suppression devices on the loop inputs in the cabinet, remove or replace them. Check for places in the field where the loop wire or lead-in cable may be pinched or chaffed. Look for wires pinched under junction box covers and where the wire enters a conduit, especially where the loop wire leaves the saw cut and enters a conduit. After checking all of the above items, you could swap out the detector but this type of failure is rarely ever related to the detector.

◇ → **YES**, Did the display show **L hi**?

◇ → **NO**, The display must have been **L lo** then. This indicates an intermittent shorted loop or -25% inductance change. Using a MegOhm meter, measure the resistance from one of the loop wires to earth ground. It should be greater than 50 megOhms. Inspect the loop. Look for exposed wires or debris pressed into the saw cut. Check for places in the field where the loop wire or lead-in cable may be pinched or chaffed. Look for wires pinched under junction box covers and where the wire enters a conduit, especially where the loop wire leaves the saw cut and enters a conduit. **If your cabinet has lightning or surge suppression devices on the loop inputs in the cabinet, remove or replace them.**

◇ → **YES**, This indicates an intermittent open loop or +25% inductance change. If you have any splices that are not soldered and sealed with an adhesive heat shrink or epoxy resin, replace the splice with one that is. Tighten all screw terminals in the signal cabinet that the loop circuit uses. Check solder joints in the loop circuit, especially on the harness itself. Disconnect and reconnect any connector used in the loop circuit and check for loose pins and sockets in these connectors.

8.5 Troubleshooting Intermittent Detector Lock Ups

Have you been able to see the detector display while the loop was locked up?

◇ → **NO**, See **Troubleshooting Intermittent Loop Fail Problems** and follow the path for unable to see the detector display while the loop failure was occurring.

◇ → **YES**, Were more than two segments lit in the bargraph on the LCD?

◇ → **NO**, Problems of this type tend to be difficult to isolate due to the many possible causes and the short duration of the symptom (usually less than 30 minutes). If the problem occurs more frequently in the morning or when raining, suspect a short to earth ground in the loop / lead-in circuit. This can usually be verified by testing with a MegOhm meter but not always. Vibration can also be a possible cause. Loop wires may be moving slightly in a conduit due to vibrations from truck traffic. Utility lids in the street near the loop may also be a source of problems. Ensure that lids near a loop are bolted down so that they cannot move. Check that each set of loop wires is twisted together in each pull box and that lengths are not excessive. And also see **Troubleshooting Intermittent Loop Fail Problems** and follow the path for a loop failure that displays **L lo** on the LCD.

◇ → **YES**, See **Troubleshooting Intermittent Loop Fail Problems** and follow the path for a loop failure that displays **L lo** on the LCD.

8.6 Things To Know About Loops

Always use a wire with cross-linked Polyethylene insulation (insulation type XLPE) for loop wire.

Typical sensing height is $\frac{2}{3}$ of the shortest leg of a loop. Therefore, a 3' x 6' loop will have a detection height of 2'.

The inductance of a conventional four-sided loop can be estimated using the formula:

$$L = P \times (T^2 + T) / 4$$

Where: L = Loop Inductance in microhenries

P = Loop Perimeter in feet

T = Number of Turns of Wire

Therefore, a 3' by 6' loop with 4 turns would have an inductance of:

$$L = (3 + 6 + 3 + 6) \times (4^2 + 4) / 4$$

$$L = 18 \times (16 + 4) / 4$$

$$L = 18 \times 20 / 4$$

$$L = 18 \times 5$$

$$L = 90 \text{ microhenries}$$

Loop Feeder cable typically adds 0.22 microhenries of inductance per foot of cable.

Total inductance of loops connected in series:

$$L_{\text{TOTAL}} = L_1 + L_2 + L_3 + \dots + L_N$$

Total inductance of loops connected in parallel:

$$L_{\text{TOTAL}} = 1 / [(1 / L_1) + (1 / L_2) + (1 / L_3) + \dots + (1 / L_N)]$$

Upswung.com