

AN INTRODUCTION TO YOUR AUTOMATIC GATE LOCK

Please read the entire instruction manual before installing the automatic gate lock.

How the Automatic Gate Lock Operates

The Zareba Automatic Gate Lock works with an Automatic Gate Opener to securely lock your gate into position without having to step out of your vehicle. The Automatic Gate Lock is wired into your gate opener control box, and when an input device such as a transmitter or keypad is used to open the gate, the Automatic Gate Lock disengages. The gate will then swing open. When closing the gate, the gate retracts and the gate lock automatically engages to secure the gate in the closed position.

The Automatic Gate Lock provides an extra level of protection for your property. In addition, it also provides stability for your gate by securely locking your gate into position. Thus, damaging affects, such as wind, are minimized. The result is your gate and automatic gate opener will stay in excellent working condition for a much longer time.

NOTE: Due to various types of gates and mounting applications, mounting hardware has not been included with the Automatic Gate Lock. All hardware necessary to mount the Automatic Gate Lock can be purchased from your local hardware store.

NOTE: Due to various types of gates and mounting applications, this manual shows examples of the two most common types of installations. These two types of installations should give insight to most other installations.

NOTE: In order for the Automatic Gate Lock to work properly, the gate must close firmly against the stop gate post or closed position stop plate. To achieve the desired closed position, you may need to slightly adjust the gate opener closed limit set points. Instructions for adjusting the closed limit set points are included in your Automatic Gate Opener manual.

NOTE: If you are installing the Automatic Gate Lock on a Push-to-Open gate (the actuator is fully retracted when the gate is in the closed position), the lock must be installed on the outside of the gate.

Tools/Materials Needed

Electric drill, screwdriver, wrenches, hammer, marker, and mounting hardware.

Parts Included (Fig. 1)

Automatic Gate Lock w/ 25' Cable (1); Gate Lock Receiver (1); Clevis Pin (1); Lock Cap (1); Manual-Open Keys (2); 8" Tie Wrap-Black (6); and Zareba Label (1).

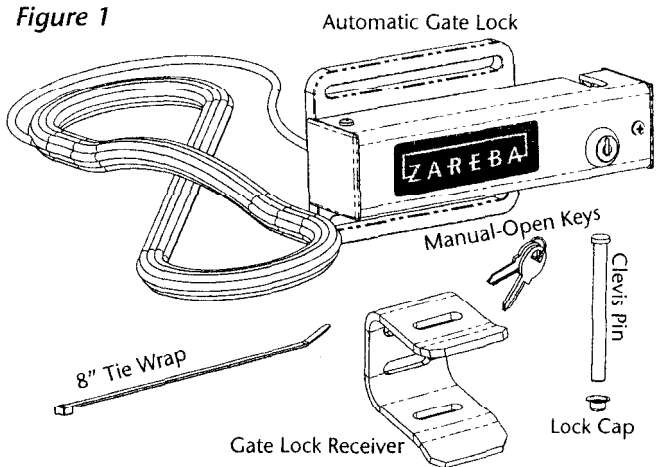

Determining the Proper Hardware for Your Gate

NOTE: The Automatic Gate Lock is designed to accommodate hardware up to 5/16" diameter. Always use lock washers and lock nuts to ensure secure mounting.

Wrought Iron or Flat Panel Gates

For installations on most wrought iron or flat panel gates, you will need to use carriage bolts with washers and lock nuts to secure the Automatic Gate Lock and Gate Lock Receiver (see Fig. 2).

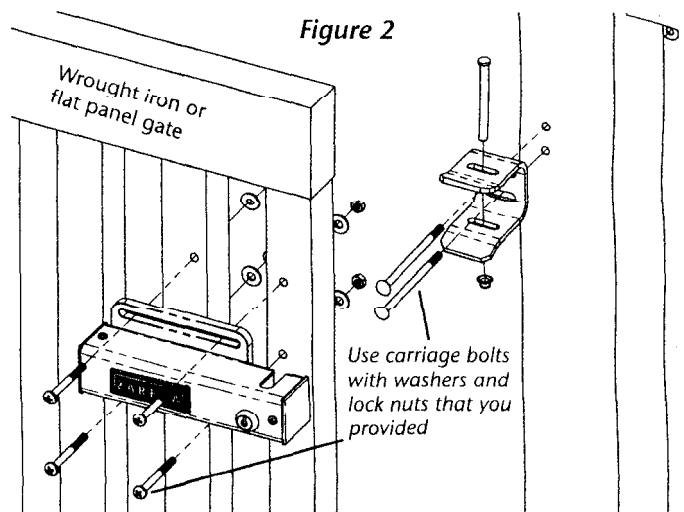

Chain Link or Thin Wall Tube Gates

For installations on most chain link or thin-walled tube gates you will need to use U-bolts with saddles, washers and lock nuts to secure the Automatic Gate Lock. You will also need to use carriage bolts with washers and lock nuts to secure the Gate Lock Receiver (see Fig. 3).

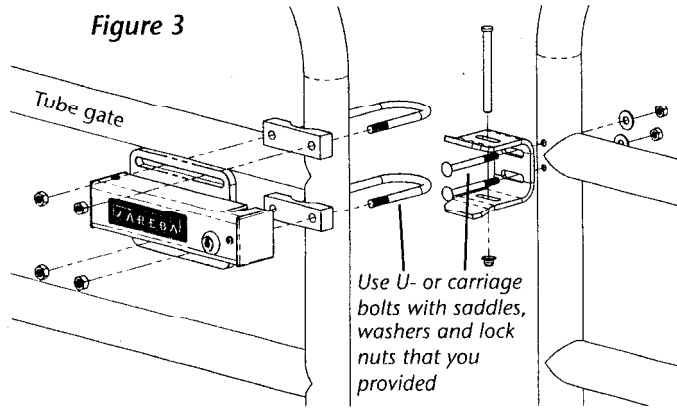

NOTE: You may need to reinforce the gate and lock mounting area with a metal reinforcement plate (see Fig. 4A and 4B).

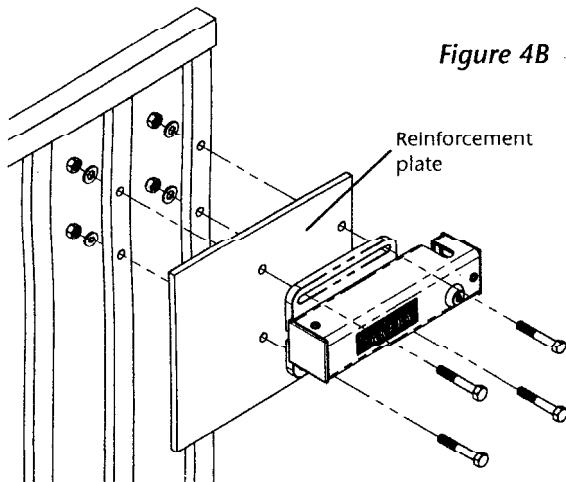
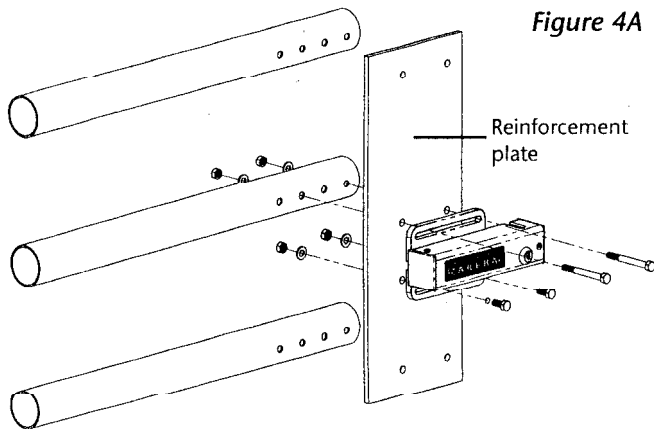

Once you have obtained the proper mounting hardware you can begin installing the Automatic Gate Lock.

INSTALLING THE AUTOMATIC GATE LOCK

NOTE: The Automatic Gate Lock can be installed on single or dual gates. Use the appropriate instructions for your type of gate.

Single Gate Installation

Step 1

Assemble the Automatic Gate Lock and Receiver by putting the clevis pin through the receiver clevis pin slots (do not fasten the locking cap). Position the opening in the Automatic Gate Lock over the Receiver and clevis pin. Push firmly until the Automatic Gate Lock locking mechanism closes around the Receiver clevis pin.

Step 2

With the gate in the closed position, place the Automatic Gate Lock and Receiver assembly onto the gate to determine the best location for mounting. The Automatic Gate Lock and Receiver should be level and aligned with the Gate Opener (actuator). Also, ensure the Receiver is aligned and against the gate post it will be mounted on (see Fig. 5).

Step 3

Once the position of the Automatic Gate Lock and Receiver is determined, use a marker or scribe to mark the drill hole locations for the Receiver and the Automatic Gate Lock. After marking hole locations remove the clevis pin from the Receiver.

NOTE: When marking the location of the drill holes for the Receiver, make the marks in the middle of the Receiver bolt slots to allow for slight adjustments.

Step 4

Drill the appropriate sized holes through the gate post and fasten the Receiver to the gate post using the carriage bolts, washers and lock nuts you have supplied (see Fig. 2 and 3).

NOTE: If mounting on a wrought iron or flat panel gate, or if you are using a reinforcement plate, recheck the Automatic Gate Lock's position and ensure that it lines up correctly (level and aligned with the gate opener) before drilling the mounting holes (see Fig. 5).

Figure 5

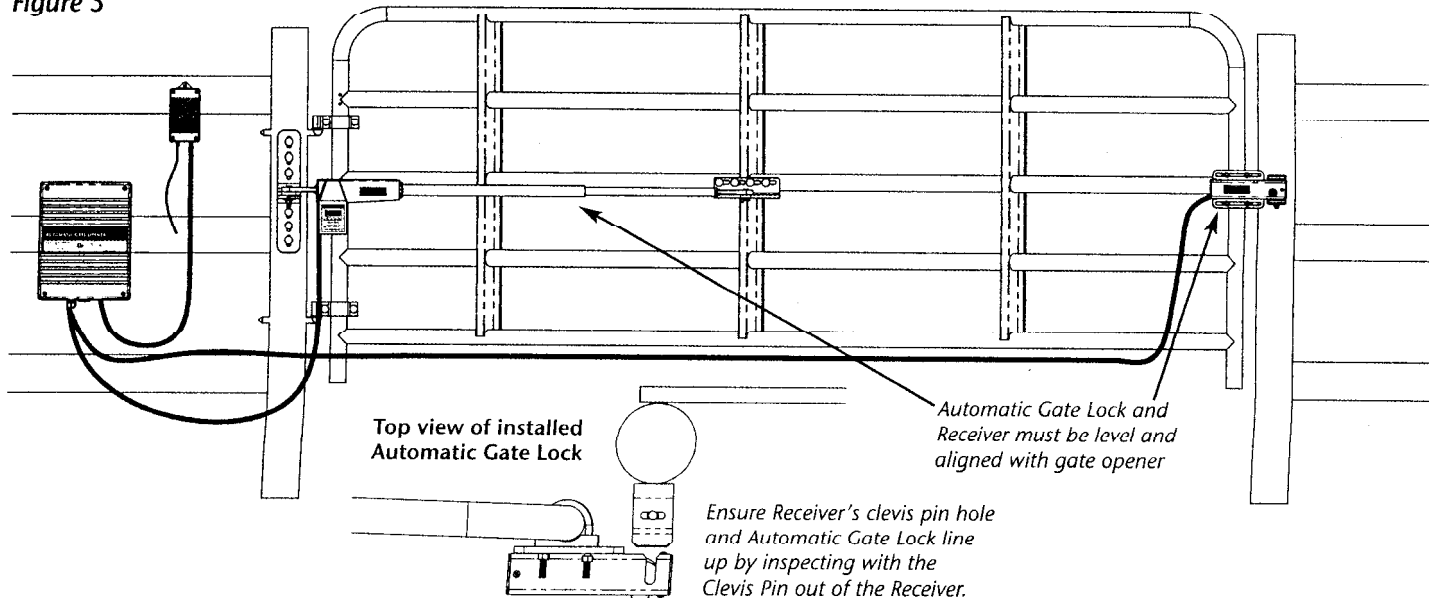

Step 5

Once you have rechecked the Automatic Gate Lock position to the Receiver, mount the Automatic Gate Lock using the U-Bolts with saddles you supplied. Or drill the appropriate sized holes through the gate or the reinforcement plate, and then use the appropriate hardware you have supplied to mount the Automatic Gate Lock (see Fig. 2 or 3).

Step 6

Install the clevis pin into the Receiver clevis pin slots and use a hammer to pound the clevis pin into the locking cap (see Fig. 6). Proceed to **Step 7** in the "Connecting the Automatic Gate Lock to the Control Board" section.

Figure 6

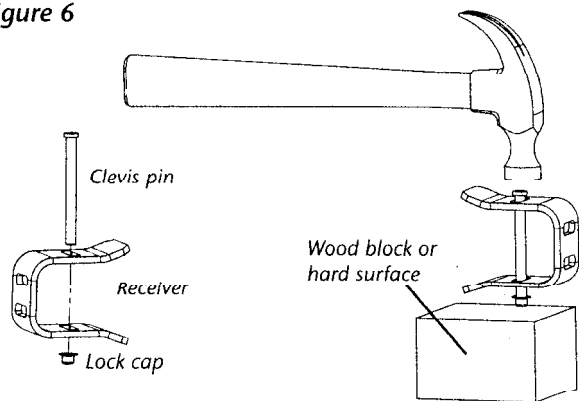

Dual Gate Installation

NOTE: In a Dual Gate installation, the Gate Opener (actuator) closest to the Control Box is referred to as Opener 1. The Gate Opener (actuator) farthest away from the Control Box is referred to as Opener 2.

NOTE: When installing the Automatic Gate Lock on a dual gate, the Control Box must be set so Opener 1 opens first and closes last. If your dual gate is not set in this manner, you must reset the DIP switch settings in the Control Box. Please refer to the "Control Board Settings" section in your Gate Opener Installation Manual.

NOTE: The Automatic Gate Lock must be mounted on the Opener 1 gate and the Receiver must be mounted on the Opener 2 gate (see Fig. 7).

Step 1

Assemble the Automatic Gate Lock and Receiver by putting the clevis pin through the Receiver clevis pin slots (do not fasten the locking cap). Position the opening in the Automatic Gate Lock over the Receiver and clevis pin. Push firmly until the Automatic Gate Lock locking mechanism closes around the Receiver clevis pin.

Step 2

With the gates in the closed position, place the Automatic Gate Lock and Receiver assembly onto the gate to determine the best location for mounting. The Automatic Gate Lock and Receiver should be level and aligned with the Gate Opener's (actuator's). Ensure the Automatic Gate Lock is aligned and against the gate for Opener 1 and the Receiver is aligned and against the gate for Opener 2 (see Fig. 7).

Figure 7

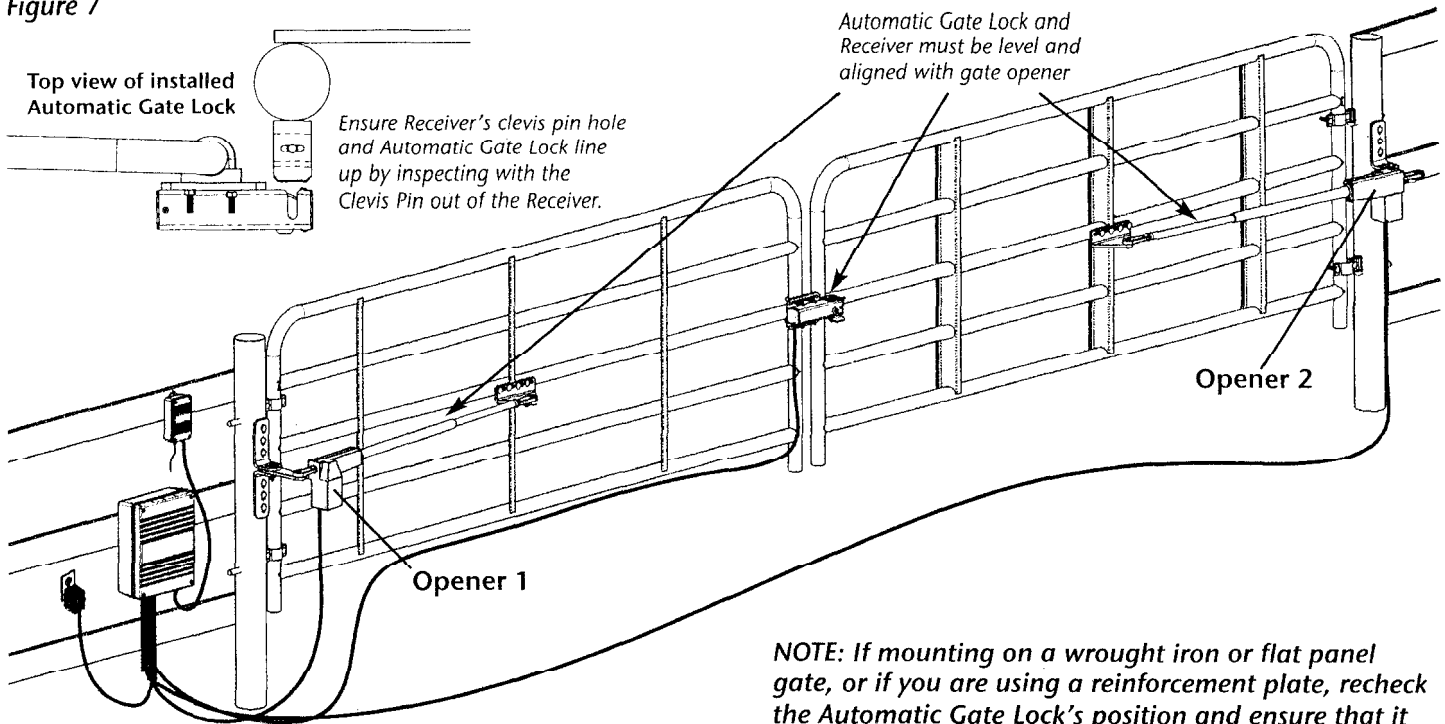

NOTE: If mounting on a wrought iron or flat panel gate, or if you are using a reinforcement plate, recheck the Automatic Gate Lock's position and ensure that it lines up correctly before drilling the mounting holes (see Fig. 7).

Step 3

Once the position of the Automatic Gate Lock and Receiver is determined, use a marker or scribe to mark the drill hole locations for the Receiver and the Automatic Gate Lock. After marking hole locations remove the clevis pin from the Receiver.

NOTE: When marking the location of the drill holes for the Receiver, make the marks in the middle of the Receiver bolt slots to allow for slight adjustments.

Step 4

Drill the appropriate sized holes through the gate for Opener 2 and fasten the Receiver to the gate for Opener 2 using the carriage bolts, washers and lock nuts you have supplied (see Fig. 8 and 9).

Step 5

Once you have rechecked the Automatic Gate Lock position to the Receiver, mount the Automatic Gate Lock using the U-Bolts with saddles you supplied. Or drill the appropriate sized holes through the gate for Opener 1 or the reinforcement plate, and use the hardware you have supplied to mount the Automatic Gate Lock (see Fig. 8 or 9).

Step 6

Install the clevis pin into the Receiver clevis pin slots and secure the clevis pin with the locking cap (see Fig. 6). Proceed to Step 7 in the next section.

Figure 8

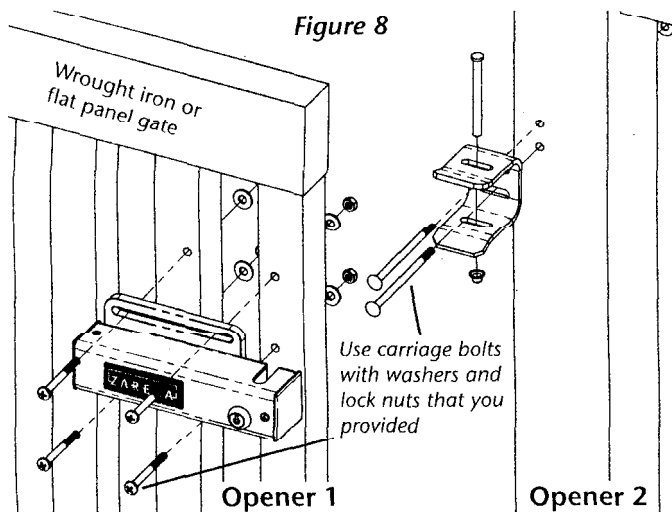
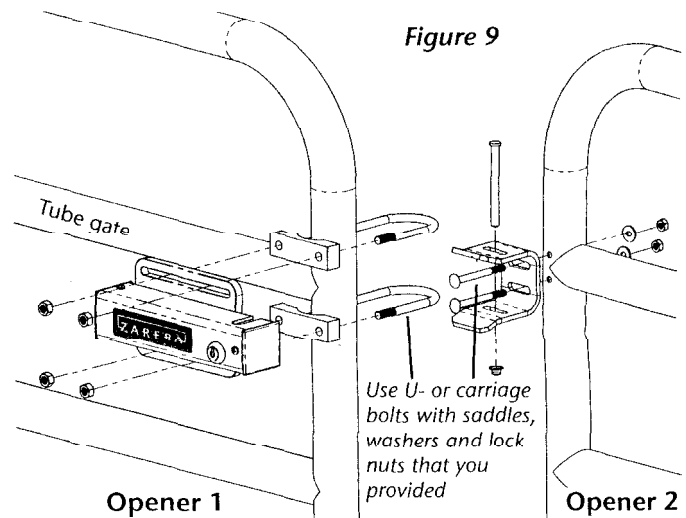

Figure 9



CONNECTING THE AUTOMATIC GATE LOCK TO THE CONTROL BOARD

Step 7

Before opening the Control Box, set the Control Box power switch to the OFF position. Open the Control Box by removing the four screws located in each corner of the Control Box and removing the cover.

Step 8

Insert the Automatic Gate Lock cable through the strain relief housing and into the Control Box by loosening the strain relief sealing nut located on the outside bottom of the Control Box and feeding the Automatic Gate Lock cable into the Control Box (see Fig. 10).

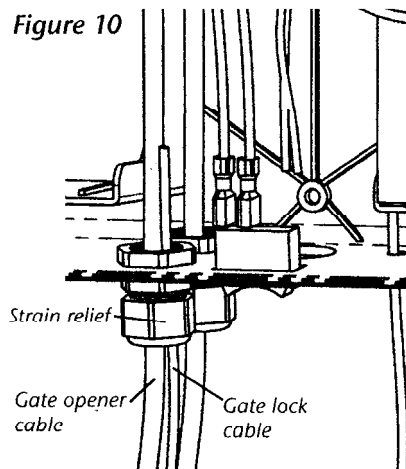

Step 9

Connect the RED and BLACK Automatic Gate Lock wires to the terminal block located on the bottom of the Control Board marked RELAY OUT by inserting the wires into the terminal block and tightening the set screw in the terminal block.

Connect the RED Automatic Gate Lock wire to the RELAY OUT terminal marked NO. Connect the BLACK Automatic Gate Lock wire to the RELAY OUT terminal marked RTN (see Fig. 11).

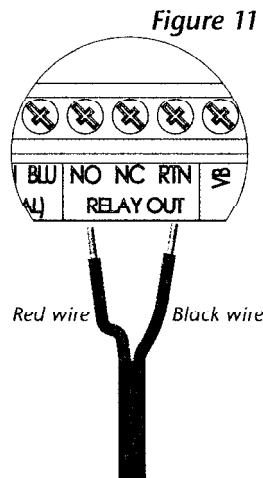

Step 10

Once the Automatic Gate Lock wires have been connected to the proper locations on the Control Board terminal block marked RELAY OUT, tighten the strain relief sealing nut so the Automatic Gate Lock cable does not move or slide through the strain relief.

Step 11

Replace the Control Box cover and secure using the four screws.

Step 12

Set the Control Box power switch to the ON position.

Step 13

Test the Automatic Gate Lock by pressing an input device such as a transmitter or keypad and run one complete gate open/close cycle. If you have a dual gate, ensure that the Opener 1 gate opens first. Upon closing, ensure that the Opener 2 gate closes first. If the Automatic Gate Lock does not function correctly, follow the three steps below.

1. Recheck that the gate lock is wired properly. Follow Steps 7–13.
2. Recheck that the Automatic Gate Lock is properly aligned and installed correctly on the gate and post. Follow Steps 1–6 for a single or dual gate installation.
3. If the problem has not been resolved, please call Zareba Customer Support.

Note: Use caution during initial testing of gate and Automatic Gate Lock. If the Automatic Gate Lock does not open, damage to the gate can occur. To avoid damage, be prepared to turn the Control Box power switch OFF if the Automatic Gate Lock does not open before the gate starts to move.

MANUAL LOCK RELEASE

The Automatic Gate Lock can be manually opened if the Gate Opener System should be disabled by inserting the Lock Key into the lock and manually turning the Lock Release (see Fig. 12).

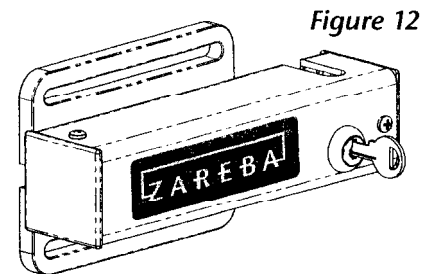

Customer Service

8:00am to 5:00pm, Central time, Monday – Friday

Zareba Systems

906 Fifth Avenue E

Ellendale, MN 56026-2193

Phone: 800-272-9877 or 507-684-3721

Fax: 507-684-3722

Email: info@zarebasystems.com