



Owner's Manual

Series 1520
Stand Alone Proximity Card Reader and Weigand Controller

Upswung.com

DoorKing, Inc.
120 Glasgow Avenue
Inglewood, California 90301
U.S.A.
Phone: 310-645-0023
Fax: 310-641-1586
www.doorking.com

Upswung.com

Use this manual with the following models

1520-080 Stand Alone Proximity Card Reader System

1520-081 Stand Alone Weigand Device Controller.

DoorKing, Inc. reserves the right to make changes in the products described in this manual without notice and without obligation of DoorKing, Inc. to notify any persons of any such revisions or changes. Additionally, DoorKing, Inc. makes no representations or warranties with respect to this manual. This manual is copyrighted, all rights reserved. No portion of this manual may be copied, reproduced, translated, or reduced to any electronic medium without prior written consent from DoorKing, Inc.

Upswung.com

Table of Contents

System Features.....	6
Important Information.....	7
Printer Information	8
SECTION 1 – INSTALLATION	
1.1 Dimensions.....	9
1.2 1520-080 Card Reader Installation	10
1.3 1520-081 Weigand Controller Installation	11
1.4 Memory Chip Installation.....	12
1.5 Terminal Description	13
1.6 Detail Wiring.....	14
SECTION 2 – PROGRAMMING	
2.1 Master Code.....	15
2.2 Relay Strike Time.....	15
2.3 Time and Date.....	15
2.4 Time Zones	
2.4.1 Programming Card Time Zones.....	16
2.4.2 Programming Hold Time Zones	16
2.4.3 Erase Time Zones.....	16
2.5 Card Code Programming	
2.5.1 Programming Single Card Code.....	17
2.5.2 Programming a Block of Card Codes.....	17
2.5.3 Deleting a Single Card Code.....	18
2.5.4 Deleting All Card Codes.....	18
2.6 Facility Code	
2.6.1 Programming Facility Codes.....	18
2.6.2 Turning Facility Codes ON / OFF.....	18
2.7 Timed Anti-pass Back	
2.7.1 Turning Anti-pass Back ON / OFF	19
2.7.2 Setting Anti-pass Back Time.....	19
2.8 Erase Transaction Memory	19
2.9 Real Time Print Mode ON / OFF	19
2.10 Card Reader Test Mode.....	19
SECTION 3 – PRINT FUNCTIONS	
Print Function Table.....	20
Selective Transaction Print.....	20

FEATURES

The 1520 series proximity card readers and weigand controllers provide users with a stand-alone access control system in a small compact package. These systems offer outstanding control features typically not found in a stand-alone system and are easy to program with their built-in programming keypad. Features include a transaction buffer, time zone programming, anti-pass back programming and connection to a serial printer for transaction reports.

The 1520 series are offered in two different packages. The 1520-080 is a complete proximity card access system and includes a 4-5 inch read range proximity reader mounted on a lighted, stainless steel faceplate and steel enclosure. The steel enclosure can be used for both indoor and outdoor applications and easily mounts to a gooseneck mounting post.

The 1520-081 is a stand-alone weigand controller that allows almost any 26-bit weigand control device (keypads, card readers, RF receivers, etc.) to be used in a stand-alone application. The controller is housed in a lockable weather resistant steel enclosure that can be mounted outdoors.

- Memory sizes: 125, 500 or 1000 card (device) codes.
- Built-in keypad for easy programming.
- Transaction buffer stores up to 3656 events.
- Input power is 16 VAC or 12-24 VDC, 125 ma.
- RS 232 port for connection to a serial printer. Transactions can be printed in real time mode or stored and printed at a later time.
- Clock and transaction buffer will maintain data in the event of a power failure for up to three days.
- Four time zones for controlling access.
- Four hold-open time zones.
- Timed anti-pass back: 1-59 minutes.

IMPORTANT INFORMATION

- Prior to starting the installation, become familiar with the instructions, illustrations and wiring diagrams in this manual.
- Never mount this device to a moving gate or gate panel, or next to a gate that causes vibration to the fence, such as a spring-loaded pedestrian gate. Continuous vibration from moving or slamming gates can cause damage to the unit in time.
- **If this system is used to activate an automatic vehicular gate operator, it must be mounted in such a way that the user cannot come into contact with the gate or the gate operator when the device is used. We recommend that the unit be installed a minimum of 10 feet away from the gate and gate operator.**
- Always disconnect power when performing service on the system.
- If the unit is mounted outdoors, be sure that the wiring to the unit is designed for direct underground burial, even if the wire is run inside a conduit.
- Surge suppression is recommended on the low voltage input power line.
- Instruct the end user on the safe and proper operation of this device.
- **Instruct the end user to read and follow these instructions. Instruct the end user to never let children play with or operate any access control device. This Owner's Manual is the property of the end user and must be left with them when installation is complete.**

Upswung.com

PRINTER INFORMATION

The 1520 can be connected directly to a serial printer to print transactions in real time mode as they occur, or to print the data stored in the transaction buffer when commanded. For a complete list of all printer functions, see page 20.

- Use any SERIAL printer with an RS 232 interface, or DoorKing serial printer, P/N 1508-067.
- Set the printer for 9600 baud, 1 start bit, 8 data bits, 1 stop bit. The information on how to set these parameters should be in the manual that came with your printer.
- Use the DoorKing adapter, P/N 1587-010, to connect the wires from the 1520 to the printer connector.
- Maximum wire run for the printer interface is 500 feet using Belden 9418 wire, or equivalent.

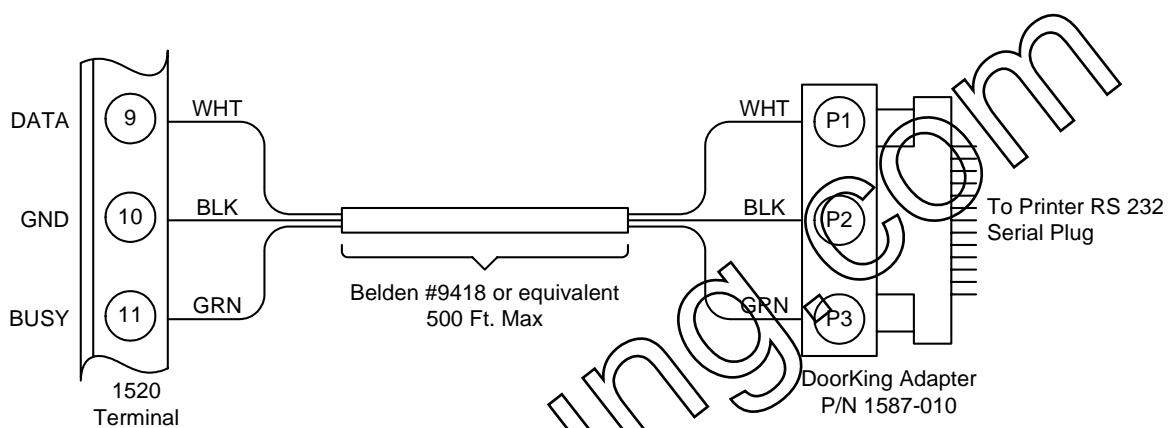

SECTION 1 - INSTALLATION

1.1 Dimensions

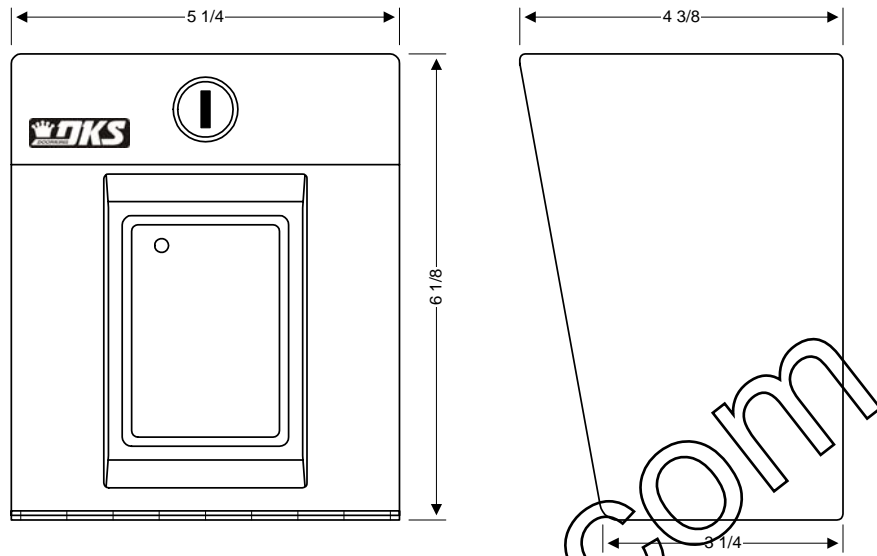

Stand Alone Proximity Card Reader

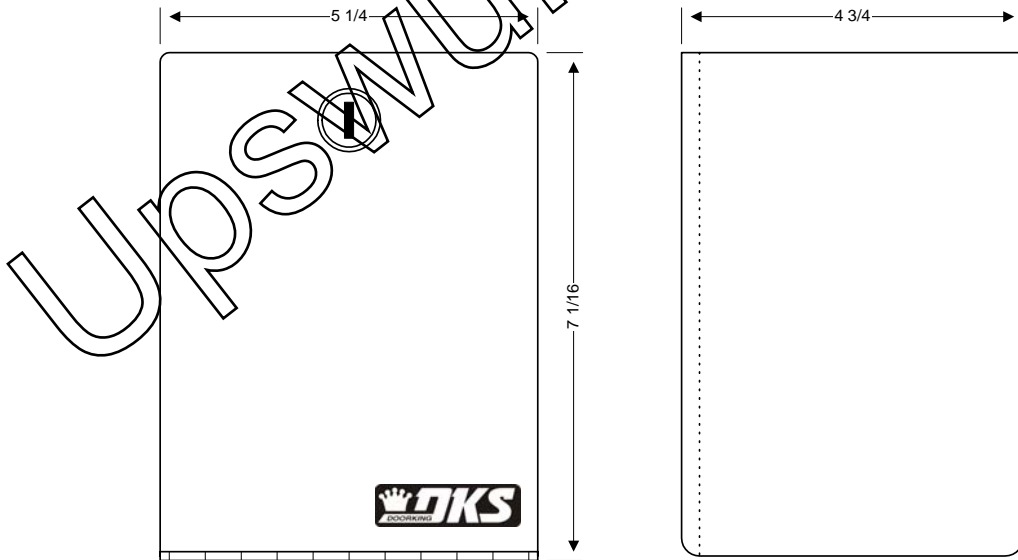

Stand Alone Weigand Controller

1.2 1520-080 Card Reader Installation

Do not mount the card reader to a moving gate, or immediately next to a gate panel or pedestrian gate. Continuous vibration from slamming gates and vibration can cause damage to the system over time.



WARNING! If the card reader is used to activate a vehicular gate operator, it must be mounted a minimum of 10 feet away from the gate and gate operator, or in such a way that the user cannot come into contact with the gate or gate operator while using the device.

1. Open the faceplate of the card reader with the keys provide so that the programming keypad is exposed.
2. Remove four (4) 6-32 x ¼ screws from the corners of the keypad mounting plate. Save these screws as they will be used to re-install the mounting plate.
3. Carefully remove the keypad and circuit board assembly.
4. Carefully pull up on the terminal connector to disengage the proximity reader head from the circuit board. Set the circuit board aside.
5. Mount the back box. Connect conduits and route wiring into the box at this time. Be sure to clean out the back box of any debris that can cause a short.
6. Install the memory chip (see Section 1.4). **Be sure that power is OFF!**
7. Make necessary wire connections at this time (see Section 2).
8. Re-install the terminal connector onto the circuit board by carefully pushing it down onto the connector.
9. The default **MASTER CODE** is 9999. If the master code is to be changed, refer to Section 3.1 to reprogram the master code prior to re-installing the keypad mounting plate. The memory chip must be installed and the system powered to change the master code.
10. Re-install the keypad mounting plate using the four (4) 6-32 x ¼ screws removed in step 2.

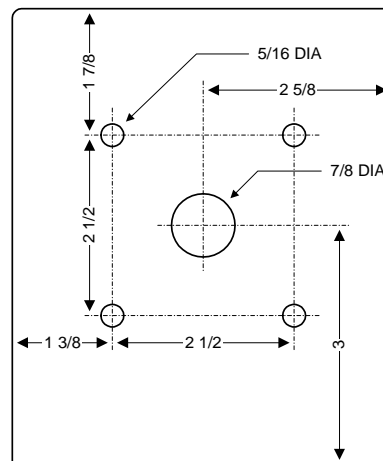
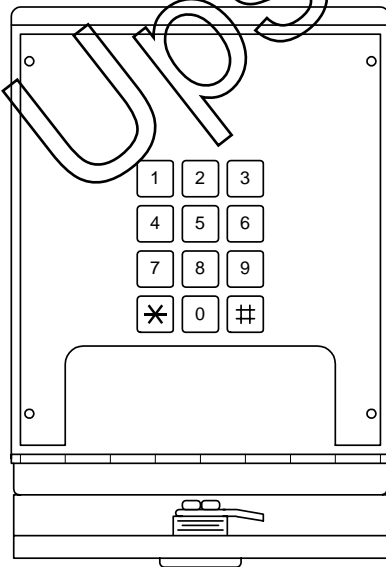

Back View

1.3 1520-081 Weigand Controller Installation

1. Open the faceplate of the controller with the keys provide so that the programming keypad is exposed.
2. Remove four (4) 6-32 x ¼ screws from the corners of the keypad mounting plate. Save these screws as they will be used to re-install the mounting plate.
3. Carefully remove the keypad and circuit board assembly and set it aside.
4. Mount the enclosure. Connect conduits and route wiring into the box at this time. Be sure to clean out the back box of any debris that can cause a short.
5. Carefully remove the terminal connector from the circuit board and make necessary wire connections at this time (see Section 2).
6. Install the memory chip (see Section 1.4). **Be sure that power is OFF!**
7. The default **MASTER CODE** is 9999. If the master code is to be changed, refer to Section 3.1 to reprogram the master code prior to re-installing the keypad mounting plate. The memory chip must be installed and the system powered to change the master code.
8. Re-install the terminal connector onto the circuit board and re-install the keypad mounting plate using the four (4) 6-32 x ¼ screws removed in step 2.

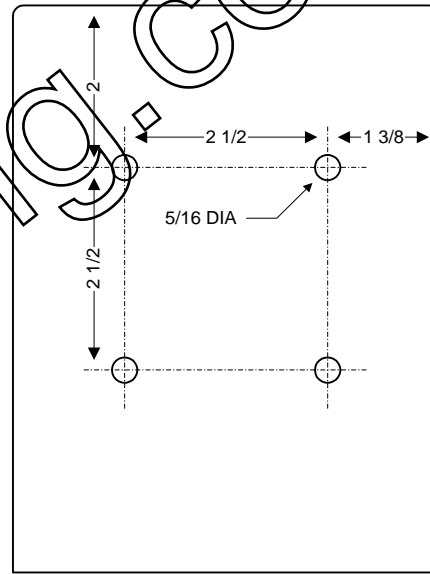
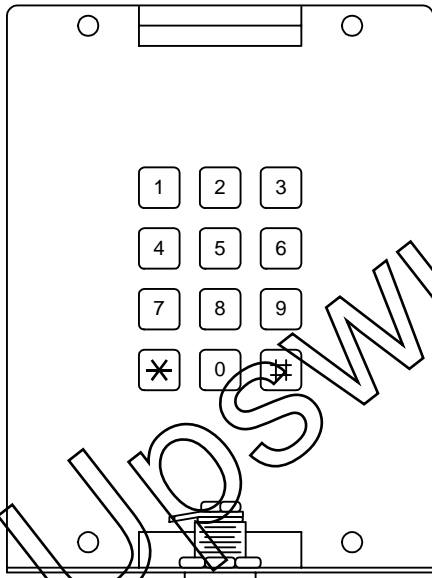

Back View

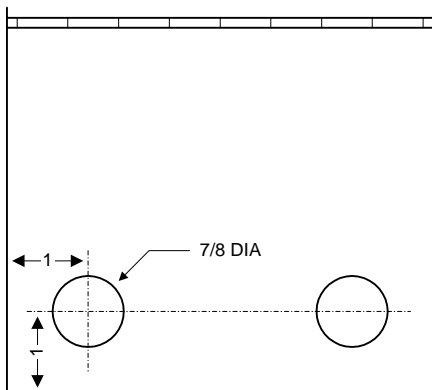

Bottom View

1.4 Memory Chip Installation

The memory chip for this system is packaged in a separate box and must be installed prior to powering the system. Memory chips are static sensitive. Handle them with care! **Never install the memory chip with power applied to the controller.**

1. Remove the keypad mounting plate from the back box by removing the small screws located in each corner.
2. Locate the memory chip socket located on the back of the circuit board near the bottom.
3. **IMPORTANT! Be sure power is OFF.**
4. Carefully remove the memory chip from its packaging and install it so that the small indentation is pointed up. Be sure that all eight pins are properly seated in the socket.
5. Re-install the keypad mounting plate using the screws removed in step 1.

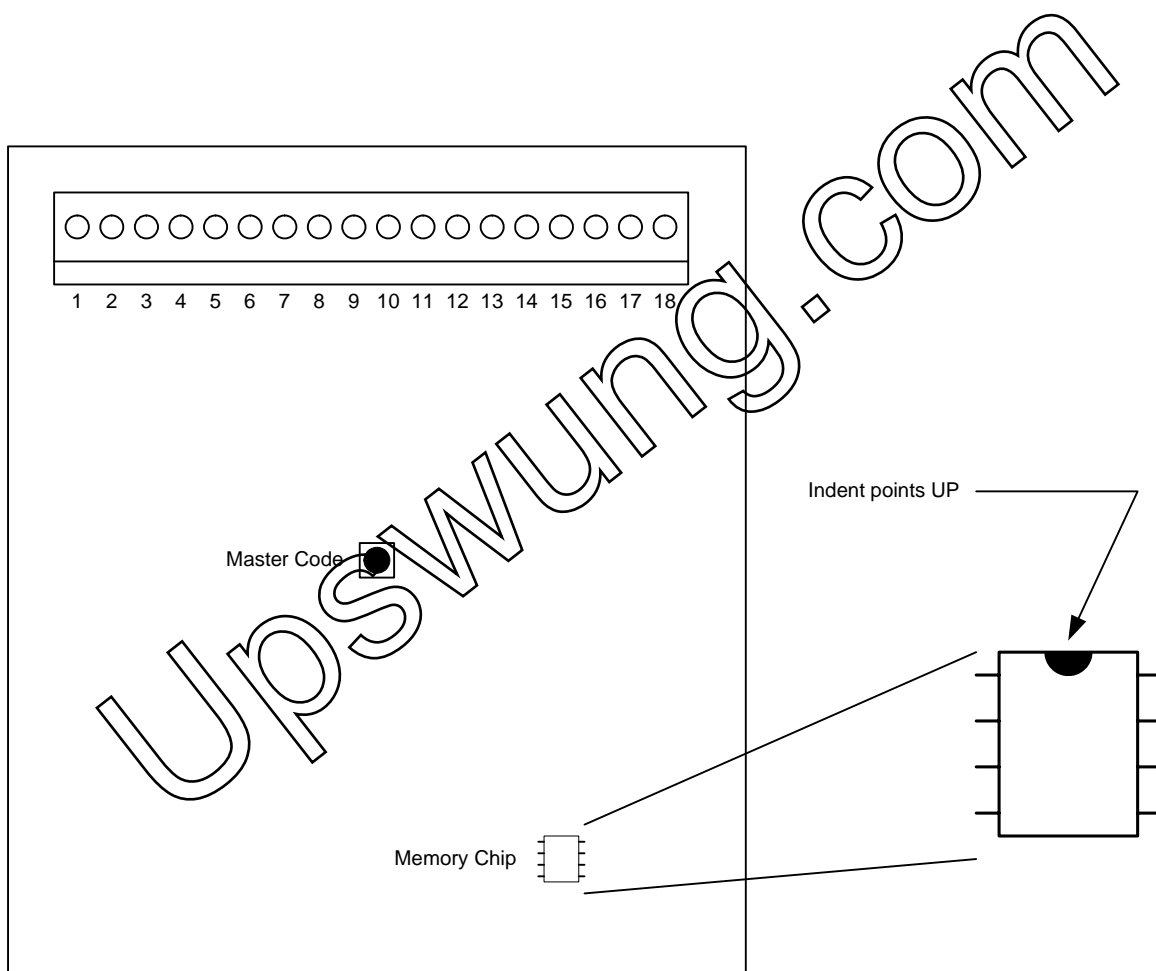

1.5 Terminal Description

TERMINAL	DESCRIPTION
1	16 VAC, 20 VA Input Power or 12-24 VDC.
2	16 VAC, 20 VA Input Power or 12-24 VDC.
3	Earth Ground Only
4	Relay Common – 30 Volt, 1 Amp maximum.
5	Relay Normally Closed – 30 Volt, 1 Amp maximum.
6	Relay Normally Open – 30 Volt, 1 Amp maximum.
7	Switch Input. A closure between terminals 7 and 14 will cause the relay to activate for its programmed strike time. The Postal Switch is connected here.
8	Not used.
9	Printer Output – Data (White).
10	Printer Output – Common (Black).
11	Printer Output – Busy (Green).
12	Not used.
13	Not used.
14	Common
15	Weigand Input – Data 0 (Green).
16	Weigand Input – Data 1 (White).
17	Weigand Input – Common (Black).
18	Weigand Input – 12 VDC Power (Red).

The 1520 can operate on 16-volt AC power or 12-24 volt DC power. Current draw is 125ma. A 16-VAC, 20 va power transformer is supplied with the unit. **Do not power any other devices (electric strikes, magnetic locks, lights, etc.) from this transformer.**

Do not run power wiring greater than 500 feet. See chart below for wire size and distances. It is preferable to keep power wiring as short as possible. A low voltage surge suppresser (P/N 1878-010) is recommended. Be sure to properly ground the 1520. Attach a separate 12 AWG wire to terminal 3 (earth ground). Attach the other end of this wire to a good earth ground. This can be a properly grounded metal conduit, a cold water pipe, or a grounding rod driven at least 10 feet into the soil. A gooseneck post anchored or mounted on concrete does not make a good ground. Avoid any splices in wiring. If a splice is made, it must be soldered and sealed in a watertight junction box.

POWER WIRING	
Wire Size	Maximum Distance
22 AWG	100 Ft.
20 AWG	200 Ft.
18 AWG	250 Ft.
16 AWG	500 Ft.

SECTION 2 - PROGRAMMING

2.1 Master Code

The Master Code is a four-digit number that is used to access all programming functions of the 1520 controller. The default factory master code is set to 9999. We suggest that you program a new master code once the system is installed. After programming the master code, write it down and keep it in a safe place. If you forget your master code, you will need to program a new one before you can access any of the programming functions of the 1520.

1. Remove the keypad mounting plate as described in Section 1 to access the Master Code push button.
2. Press the Master Code push button once.
3. Enter a four-digit code ____ on the keypad and then press * (short beep).
4. Re-install the keypad mounting plate.

2.2 Relay Strike Time

The relay strike time sets the amount of time that the relay in the 1520 controller remains activated after a valid card (device) code is received. Setting the strike time to 00 will activate the relay for ¼ second. The factory setting is 1 second.

1. Press *03 and enter the four-digit master code (short beep).
2. Enter the relay time in seconds __ (00 – 99) then press * (short beep).
3. Press 0# together to end the programming step (long beep).

2.3 Time and Date

Set the time of the day with a four-digit number (hr/min). For example, 8:30 is entered as 0830; 11:45 is entered as 1145. You need not be concerned with AM or PM when entering the current time. When entering the month, January = 01 and December = 12. The day of the month is always entered as a two-digit number; 1st day of the month is entered as 01, the 20th day is entered as 20, etc. The year is entered with the last two digits of the current year; 2001 = 01, 2002 = 02, etc. The day of the week is entered as a single digit; Sunday = 1, Saturday = 7.

Note: the time and date must be programmed to allow transactions, real time printing and anti-pass back to work correctly.

1. Press *33 and enter the four-digit master code (short beep).
2. Enter the time of day ____ (hr/min) and then press * (short beep).
3. Enter 0 for AM or 1 for PM then press * (short beep).
4. Enter the month __ (01 – 12) then press * (short beep).
5. Enter the day of the month __ (01 – 31) then press * (short beep).
6. Enter the year __ then press * (short beep).
7. Enter the day of the week _ (1 – 7) then press * (long beep).

2.4 Time Zones

There are two types of time zones that can be used with the 1520 controller; CARD time zones and HOLD time zones. CARD time zones are applied to the individual card codes programmed into the system and HOLD time zones activate and deactivate the relay in the 1520 at predetermined times.

There are six CARD time zones. These are referenced as time zones 0 through 5. Only time zones 2 through 5 are programmable. Time zone 0 will always deny a card entry and time zone 1 will always grant a card entry. The four HOLD time zones, 6 through 9, are user programmable.

Time zone beginning and ending times must be in the four-digit 12-hour format (hr/min). For example, 8:30 is entered as 0830; 11:45 is entered as 1145. You need not be concerned with AM or PM when entering the beginning and ending times.

You need to program what days of the week the time zone is applied. The days of the week is entered as a seven digits; Sunday = 1, Saturday = 7. If you want to skip a day, enter # for the days to be skipped. For example, if a time zone is to be applied Monday through Friday only, you need to enter: 2 3 4 5 6 # # in the programming sequence. If the time zone is to be applied on the weekend only (Saturday, Sunday), you would enter 1 7 # # # # # in the programming sequence.

2.4.1 Programming Card Time Zones

1. Press *38 and enter the four-digit master code (short beep).
2. Enter a single digit time zone number _ (2 – 5) then press * (short beep).
3. Enter the time zone start time _ _ _ _ (hr/min) then press * (short beep).
4. Enter 0 for AM or 1 for PM then press * (short beep).
5. Enter the time zone end time _ _ _ _ (hr/min) then press * (short beep).
6. Enter 0 for AM or 1 for PM then press * (short beep).
7. Enter the days of the week that the time zone is applied _ _ _ _ _ _ _ (1 – 7, #) then press * (short beep).
8. Repeat steps 2-7 to enter additional time zones.
9. Press 0# together to end the programming step (long beep).

2.4.2 Programming Hold Time Zones

1. Press *38 and enter the four-digit master code (short beep).
2. Enter a single digit time zone number _ (6 – 9) then press * (short beep).
3. Enter the time zone start time _ _ _ _ (hr/min) then press * (short beep).
4. Enter 0 for AM or 1 for PM then press * (short beep).
5. Enter the time zone end time _ _ _ _ (hr/min) then press * (short beep).
6. Enter 0 for AM or 1 for PM then press * (short beep).
7. Enter the days of the week that the time zone is applied _ _ _ _ _ _ _ (1 – 7, #) then press * (short beep).
8. Repeat steps 2-7 to enter additional time zones.
9. Press 0# together to end the programming step (long beep).

2.4.3 Erase Time Zones

1. Press *39 and enter the four-digit master code (short beep).
2. Enter the time zone number to be erased _ (2 – 9) then press * (short beep).
3. Repeat step 2 to erase additional time zones.
4. Press 0# together to end the programming step (long beep).

2.5 Card Code Programming

In the following programming sequence, the term “card code” is also used to reference any 26-bit weigand device code that is being used with the 1520 controller. For example, digital entry codes or RF transmitter codes are also referred to as “card codes.” Card codes are always five-digits in length. Valid codes are 00000 – 65535. Card codes can be programmed as a block of sequential codes or can be entered individually. When programming a single card code, the beginning and ending card codes are the same.

When entering a block of card codes, the 1520 will “beep” every few seconds while the card codes are being programmed. When programming is complete, the system will emit a long beep. The 1520 will take about 1 minute to program 200 card codes. If different time zones will be assigned to different blocks of cards, then these blocks will need to be programmed separately so that the correct time zones are applied. For example, if cards 01000 through 01010 are to be assigned time zone 1 (always admit), and cards 01011 through 01100 are assigned time zone 2, then these blocks have to be entered individually.

Each card code can be assigned two time zones. If using a single time zone, enter the time zone number twice in the two-digit time zone field. For example, if using time zone 1 (always admit), enter 11 in step 4.

If you enter time zones that conflict with each other, the system evaluates each time zone individually starting with the first one. For example, if 01 is entered in step 4, time zone 0 tells the unit to never allow entry while time zone 1 tells the system to always allow entry. In this case, the system will look at time zone 0, deny access and then will look at time zone 1. Access will then be granted.

2.5.1 Programming Single Card Code

1. Press *17 and enter the four-digit master code (short beep).
2. Enter the five-digit card number _____ and then press * (short beep).
3. Enter the five-digit card number again _____ and then press * (short beep).
4. Enter the two-digit time zone number __ associated with this card, then press * (short beep, followed by a long beep – programming ends).
5. To enter additional card codes, start again at step 1.

2.5.2 Programming a Block of Card Codes

1. Press *17 and enter the four-digit master code (short beep).
2. Enter the five-digit beginning card number _____ and then press * (short beep).
3. Enter the five-digit ending card number _____ and then press * (short beep).
4. Enter the two-digit time zone number __ associated with these cards, then press * (short beep).
5. The system will emit a short beep every few seconds while programming the card codes. When the short beeps stop, wait approximately 20 seconds for a long beep, which indicates that the programming is complete.

2.5.3 Deleting a Single Card Code

This programming sequence deletes a single card code and takes it completely out of memory to free up space for other card codes. Card codes not programmed in the 1520 will not print or be stored in the transaction buffer. If you want a transaction of denied card codes (for example - a lost card), then assign time zone 00 (always deny) in card programming 2.5.1.

1. Press *18 and enter the four-digit master code (short beep).
2. Enter the five-digit card code to be deleted _ _ _ _ _ then press * (short beep).
3. Repeat step 2 to erase additional card codes.
4. Press 0# together to end the programming step (long beep).

2.5.4 Deleting All Card Codes

CAUTION: This programming step will erase ALL card codes stored in the 1520 controller.

1. Press *13 and enter the four-digit master code (short beep).
2. Enter 9 9 9 9 then press * (short beep).
3. A long beep after approximately 1-2 seconds indicates that all card codes are erased.

2.6 Facility Codes

Facility codes can be used to prevent the same card code from working at a different site or facility. The 1520 controller allows you to enter up to 10 different facility codes and allows you to decide whether to use facility codes or not.

Facility codes are three-digits in length. Valid facility codes are 000 – 255. Simply entering a facility code does not turn this feature on. This must be programmed in section 2.6.2.

2.6.1 Programming Facility Codes

1. Press *05 and enter the four-digit master code (short beep).
2. Enter the facility code number _ (1= FC 1, 2= FC 2, etc. Use 0 for FC 10), then press * (short beep).
3. Enter the three-digit facility code number _ _ _ (000-255) and then press * (short beep).
4. Repeat steps 2 and 3 to enter additional facility codes.
5. Press 0# together to end the programming step (long beep).

2.6.2 Turning Facility Codes On / Off

Factory default for this feature is OFF.

1. Press *28 and enter the four-digit master code (short beep).
2. Enter 0 to turn the facility code OFF, or enter 1 to turn the facility code ON, then press * (short beep).
3. Press 0# together to end the programming step (long beep).

2.7 Timed Anti-Pass Back

The 1520 controller has a timed anti-pass back feature that will prevent a card code from being used within a period on time from the last use of the card code. To use the anti-pass back feature, you must set the time and date (section 2.3), set the pass back time (1 to 59 minutes) and turn the anti-pass back feature ON. Factory default is OFF.

2.7.1 Anti-Pass On/Off

1. Press *25 and enter the four-digit master code (short beep).
2. Enter 0 (pass back OFF) or 1 (pass back ON) and then press * (short beep).
3. Press 0# together to end the programming step (long beep).

2.7.2 Anti-Pass Back Time

1. Press *26 and enter the four-digit master code (short beep).
2. Enter the time in minutes __ (01 – 59) then press * (short beep).
3. Press 0# together to end the programming step (long beep).

2.8 Erase Transaction Memory

CAUTION: this programming step clears the transaction memory buffer.

1. Press *36 and enter the four-digit master code (short beep).
2. Enter 9 9 9 9 and then press * (short beep).
3. In approximately 5 seconds, a long beep will be heard indicating that the transaction memory buffer is cleared.

2.9 Real-Time Print Mode

These programming steps allow you to turn the real time print feature of the 1520 controller ON or OFF. When turned ON, the printer will print the transaction as it occurs and store it in the transaction buffer. When turned OFF, the transaction is stored in the transaction buffer for printing at a later time. Factory default is OFF.

1. Press *35 and enter the four-digit master code (short beep).
2. Enter 0 (real time print OFF) or 1 (real time print ON) and then press * (short beep).
3. Press 0# together to end the programming step (long beep).

2.10 Card Reader Test Mode

The test mode allows you to determine if a card reader or other weigand device connected to the controller is functioning or not. When the controller is in the test mode, any card presented to the reader will have its facility code and card number printed.

1. Press *23 and then enter the four-digit master code (short beep).
2. The controller is now in test mode.
3. Press 0# together to end the test mode and return to normal operation (long beep).

SECTION 3 – PRINT FUNCTIONS

The table lists the many different print functions that the 1520 controller can perform. After each function is complete, a long beep will sound.

Keypad Entry	Function
*22 + master code	Prints all card codes currently stored in the system memory.
*06 + master code	Prints all facility codes currently stored in the system memory.
*40 + master code	Prints time zone information currently stored in the system memory.
*32 + master code	Prints the current date and time.
*02 + master code	Prints the programmed relay strike time.
*27 + master code	Prints the status of timed anti-pass back (On or Off).
*55 + master code	Prints the size of the memory chip currently installed in the controller (125, 500 or 1000).
*37 + master code	Prints the transactions currently stored in the transaction buffer.
*31 + master code	Prints the status of the real time print mode (On or Off).

3.1 Selective Transaction Print

In addition to the above print functions, the following programming sequence will print transactions for a selected month and a selected day of the month.

1. Press *34 and then enter the four-digit master code (short beep).
2. Enter the month __ (01 = January, 12 = December) and then press * (short Beep).
3. Enter the day of the month __ and then press *.
4. The printer will start to print the transactions stored for the selected month and day. When complete, a long beep will sound.

Upswung.com