



9292 Jeronimo Road
Irvine, CA 92618
Tel.: (949)-598-1600
Fax: (949)-598-1690

PINpad™ Wiegand Reader

Single-Gang box 8-bit Wiegand Reader with Keypad

Model 32788

INSTALLATION GUIDE - 7393760, REV E

October 19, 2007

Overview

The Wiegand PINpad is a Wiegand reader and keypad combined in the same rugged housing. It is fully sealed against the environment and the wide operating temperature range makes it ideal for Indoor-Outdoor use, even under the most extreme conditions. The Wiegand PINpad mounts easily to standard electrical hardware, such as a single-gang box, and the attractive appearance makes it a welcome addition to any location.

The unique design of the Wiegand PINpad transmits both card and keypad data over the Wiegand lines, eliminating the need to pull separate wiring for each device.

The Wiegand PINpad is ideal for Access Control, Time and Attendance or other applications where Wiegand card data and/or Keypad data is required. For Access Control applications you can use just the keypad during low security periods, the Wiegand reader during high security periods or both for maximum security.

There is no need to cut two wall openings as both the reader and keypad are combined. Additionally, the Wiegand PINpad transmits data using Wiegand output making it a direct replacement* for your existing Wiegand output hardware.

*The Wiegand PINpad may have a higher current draw than the existing equipment. Make sure that the existing wiring and panel are capable of the increased current requirement.

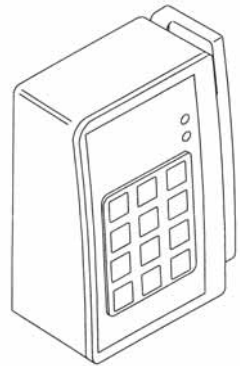

Output

The Wiegand PINpad transmits data over the D0 and D1 lines in accordance with the Wiegand output format (see Wiegand Reader Output). The binary code embedded within a Wiegand card is read when the card is properly swiped and sent directly from the reader, the reader performs no calculation on the card data.

Each Keypad entry is transmitted as an eight-bit binary number with built in error checking. The algorithm is described in detail in the Keypad Data section.

The Hold Line allows users to store card data. If, while card data is stored, another card is "swiped" the new card data will replace the stored card data. Keypad data is always sent directly to the D0 and D1 lines.

Specifications

Base Part Number	Input Voltage	Current	Operating Temperature	Cable Distance
310	5 – 12 VDC	40mA (typical)	-31°F to + 149°F (-35°C to + 65°C)	<p>Maximum cable distance is 100 feet (30.5 m) using six conductor, shielded 18 AWG cable.</p> <p>For distances greater than 100 feet the unit should be powered locally and a Line Extender used to transmit the data up to 5,000 feet (1524 m).</p>

Wiring

For maximum performance the Wiegand PINpad should be connected to the host panel with a six-conductor, shielded, 18 AWG cable.

The tan wire (Case Ground) should be connected to an earth ground as close to the Wiegand PINpad as possible.

Wire Color	Description
Red	+5 to 12 VDC, 120 mA Typical, 150 mA Max.
Black	DC Ground
Green	Data 0. Transmits the Binary "0"s of a Wiegand Data Stream (See Wiegand Reader Output)
White	Data 1. Transmits the Binary "1"s of a Wiegand Data Stream (See Wiegand Reader Output)
Brown	LED Control. High = Red on/Green off. Low = Red off/Green on.
Blue	Hold Line. High = Inactive. Low = Stores up to 64 bits of card data.
Tan	Case Ground. Connect to "Earth Ground" as close to the PINpad as possible.

Wiegand Reader Output

Wiegand readers convert the binary codes embedded within a Wiegand card into electronic data, see Figure 1. The direction in which a card is passed through the reader will affect the order in which the data is sent from the reader. Bits are recognized as a line transitioning low (below 1.1 volts) for 50 μ Sec.

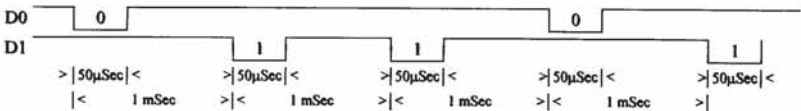

Figure 1 Binary Stream "01101" Wiegand Output

Keypad Data

Each keypad entry will transmit the respective eight-bit binary word, see Table 1. The four Least Significant Bits (LSB) represent the binary equivalent of the decimal character being entered in the keypad (except for the * and the # keys). The four Most Significant Bits (MSB) represent the “Ones complement” of the four LSBs.

Table 1 Keypad 26-bit Data Stream

Keypad Entry	MSB	LSB	Keypad Entry	MSB	LSB
0	1111	0000	6	1001	0110
1	1110	0001	7	1000	1111
2	1101	0010	8	0111	1000
3	1100	0011	9	0110	1001
4	1011	0100	*	0101	1010
5	1010	0101	#	0100	1011

*Replace the “1”s with “0”s and the “0”s with “1”s to determine the Ones Complement of a binary number.

Mounting

The Wiegand PINpad is designed to mount to a standard single-gang electrical box using standard mounting hardware. Mount the Wiegand PINpad use the following procedure, see Figure 2.

1. Confirm there is +5 to 12 VDC on the host panel cable and remove power from the cable.

WARNING: Exceeding +12 VDC will permanently damage the unit and void the warranty.

2. Attach the Base Unit (A) cable to the host panel cable (B). Bundle the slack cable to allow the Base Unit (A) to sit flush against the single-gang box (C).
3. Attach the Base Unit ground (Tan) wire (B1) to an earth ground.
4. Attach the Base Unit (A) to the single gang box (C) using two 6-32 screws (D) of appropriate length.
5. Attach the Base Unit connector (E) to the keypad connector (E1). The cable and socket are keyed to ensure proper connection and the cable should connect easily. If it is difficult to connect the cable, check that the key is aligned.
CAUTION: Do not force the cable into the connector.
6. Attach the keypad (G) to the Base Unit (A) using the four 6-32 screws (F) provided.
7. Attach the label (H) to the keypad (G).
8. Power the host panel cable and confirm the Red LED is illuminated.

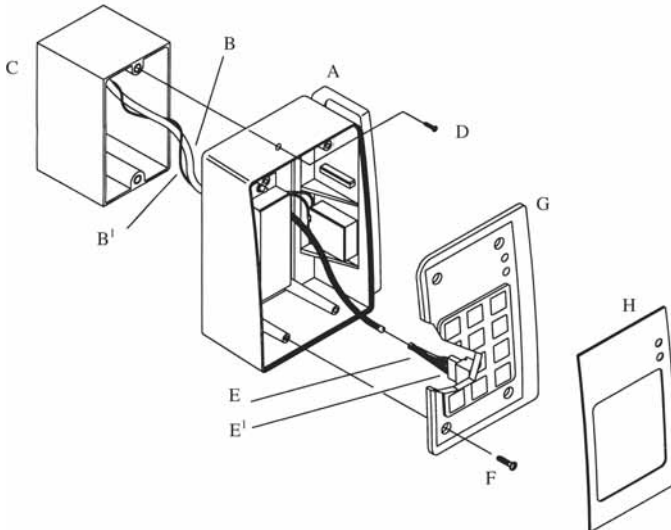

Figure 2 Mounting Procedure

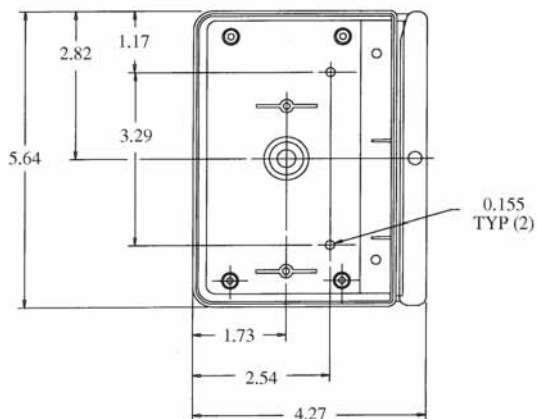

Figure 3 Base Unit Dimensions

Troubleshooting

To confirm that the unit is operating properly:

1. Attach an earth ground point to the Tan wire protruding from the base unit.
2. Attach +5 to 12 VDC to the red line in the cable.
3. Attach a DC Ground point to the Black line in the cable.
4. Monitor the current draw and confirm that the current is not greater than 150mA. If the current draw exceeds 150 mA remove power immediately and call HID Tech Support.
5. Confirm the Red LED is illuminated. If it is not, remove power and call HID Tech Support.
6. Connect the Brown wire in the cable to DC ground and confirm that the LED turns green. If it does, the unit should be working properly. If you are still having problems call HID Tech Support.

Regulatory

For regulatory compliance, the drain wire is to be disconnected at the power supply end of the I/O cable.

FCC

This device complies with part 15 of the FCC rules. Operation is subject to the following two conditions: (1) this device may not cause harmful interference, and (2) this device must accept any interference received, including interference that may cause undesired operation.

Changes or modifications not expressly approved by the party responsible for compliance could void the user's authority to operate the equipment.

UL

This Proximity Reader is intended to be powered from a limited power source output of a previously certified power supply. This Reader is intended to be used with UL 294 Listed Control Equipment.

Note: This product was evaluated by UL to operate between -31°F to + 149°F (-35°C to + 65°C).

CE Marking

HID Global hereby declares that this proximity reader is in compliance with the essential requirements and other relevant provisions of Directive 1999/5/EC.

NCC Marking

經型式認證合格之低功率射頻電機，非經許可，公司、商號或使用者均不得擅自變更頻率、加大功率或變更原設計之特性及功能。低功率射頻電機之使用不得影響飛航安全及干擾合法通信；經發現有干擾現象時，應立即停用，並改善至無干擾時方得繼續使用。前項合法通信，指依電信法規定作業之無線電通信。低功率射頻電機須忍受合法通信或工業、科學及醫用電波輻射性電機設備之干擾。

According to "Administrative Regulations on Low Power Radio Waves Radiated Devices" Without permission granted by the DGT, any company, enterprise, or user is not allowed to change frequency, enhance transmitting power or alter original characteristic as well as performance to a approved low power radio-frequency devices. The low power radio-frequency devices shall not influence aircraft security and interfere legal communications; If found, the user shall cease operating immediately until no interference is achieved. The said legal communications means radio communications is operated in compliance with the Telecommunications Act. The low power radio-frequency devices must be susceptible with the interference from legal communications or ISM radio wave radiated devices.

Call HID

For more information about this and other HID products call HID Global at (800) 243-2563.

HID Global (California, USA)

support: tech@hidcorp.com
main: (949) 598-1600
support: 1-800-237-7769
fax number: (949) 598-1690

HID Corporation, Ltd. (Haverhill, UK)

support: eusupport@hidcorp.com
main: +44 (0) 1440 714 850
support: +44 (0) 1440 711 822
fax number: +44 (0) 1440 714 840

HID Asia Pacific Ltd. (Hong Kong)

support: asiasupport@hidcorp.com
main: (852) 3160 9800
support: (852) 3160 9802
fax number: (852) 3160 4809