

Installation and Maintenance Manual



Barrier Gate Operator

Models BG770 & BG790

Contents

<u>General Product Information</u>	4
<u>Specifications</u>	4
<u>Safety Instructions</u>	6
<u>Before Installation</u>	6
<u>During Installation</u>	6
<u>After Installation</u>	7
<u>Preparing the Installation</u>	8
<u>Unpack Carton</u>	8
<u>Preparing the Site</u>	9
<u>Preparing the Operator</u>	10
<u>Installation</u>	11
<u>Step 1: Mounting</u>	11
<u>Step 2: Arm Fabrication</u>	12
<u>Step 3: Wiring Connections</u>	13
<u>Step 4: Arm Attachment</u>	14
<u>Step 5: Arm and Turnbuckle Shaft Adjustments</u>	16
<u>Step 6: Limit Switch Adjustments</u>	18
<u>Optional Accessories</u>	19
<u>Vehicle Detectors</u>	19
<u>Radio Controls</u>	19
<u>Card Readers, Keypads, or other</u>	20
<u>Operating Instructions</u>	21
<u>Electrical Operation</u>	21
<u>Manual Operation</u>	21
<u>Troubleshooting</u>	22
<u>1. Power</u>	22
<u>2. Accessories</u>	23
<u>3. Primary Voltage Circuit</u>	23
<u>4. Low Voltage Circuit</u>	24
<u>General Reference Information</u>	25

<u>Required Maintenance-Normal Usage</u>	26
<u>Warranty Policy</u>	27
<u>BG770 Drawing and Parts List</u>	28
<u>BG770 Exploded View</u>	28
<u>BG770 Parts List</u>	29
<u>BG790 Drawing and Parts List</u>	30
<u>BG790 Exploded View</u>	30
<u>BG790 Parts List</u>	31

General Product Information

Specifications

Specifications are for both model BG770 and model BG790 unless otherwise noted.

POWER

Line voltage is designated by third suffix of gate part number. For amp draw, see motor nameplate.

- 11; 115VAC, 1 Phase, 60Hz
- 21; 230VAC, 1 Phase, 60Hz
- 81; 208VAC, 1 Phase, 60Hz
- 83; 208VAC, 3 Phase, 60Hz
- 23; 230VAC, 3 Phase, 60Hz
- 43; 460VAC, 3 Phase, 60Hz
- 53; 575VAC, 3 Phase, 60Hz

MOTOR

Squirrel cage induction type (3 phase) or capacitor start induction type (1 phase), continuous duty, 1725 RPM. Horsepower is designated by second suffix of operator part number.

- 50; 1/2 Horsepower

OVERLOAD PROTECTION

Automatic reset (3 phase operators) or manual reset (1 phase operators) thermal overload.

ELECTRICAL BOX

NEMA 1 general purpose painted steel enclosure, contains all motor control equipment. Enclosure removable from operator.

CONTROL CIRCUIT

Class II, 24VAC

LIMIT SWITCHES

Adjustable, driven limit switches, operate in class II circuit. Not affected by removal of motor.

POWER ON/OFF SWITCH

Enclosed toggle switch, HP rated.

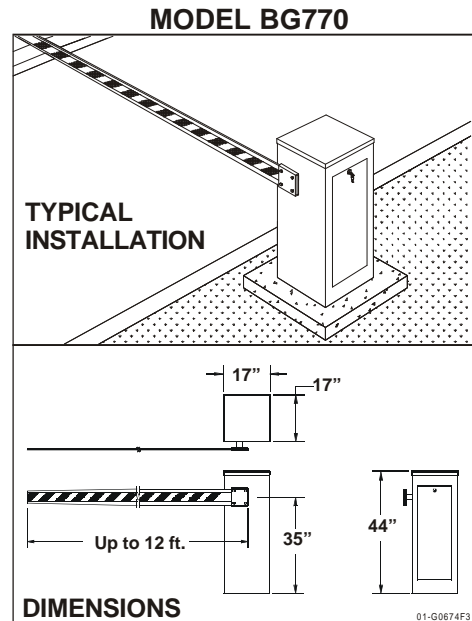

Figure 1

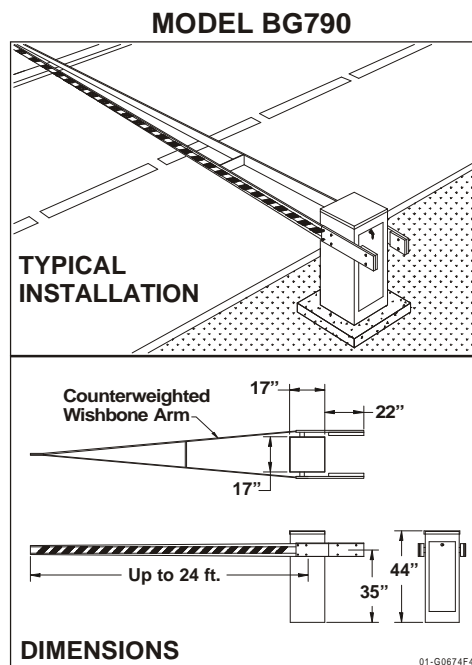

Figure 2

OPERATION

Prewired terminal strip accepts field connection of any access control device with normally open (N.O.) output contact (most access control equipment) and when required, a separate OPEN/CLOSE pushbutton (supplied).

Plug-in connectors are included for addition of a loop detector to open and/or a loop detector to hold open (not supplied). Activation of access device open button, or loop detector to open will raise gate. Gate will lower automatically unless hold open loop detector is activated or unless CLOSE button wiring has been made, in which case gate will remain open until CLOSE button is pushed.

An optional timer will extend the time that the gate remains open. AUTO/MANUAL switch holds arm in vertical position.

SPEED REDUCTION

Wormgear-in-oil-bath, 60:1

ARM TYPE

MODEL BG770: One piece type to 12 feet.

MODEL BG790: Counterweighted wishbone type to 24 feet.

ARM SPEED

MODEL BG770: Opens in 4 seconds

MODEL BG790: Opens in 11 seconds

LUBRICATION

Permanently lubricated bearings in motor. Low temperature gear oil normally never needs replacement. Gear oil is Mobil SHC 630 or equivalent.

MOUNTING

Pad mount

ENCLOSURE

Weatherproof, heavy gauge, pregalvanized steel, powdercoat finish, top and side access covers with key lock.

Safety Instructions



WARNING

To reduce the risk of injury or death, **it is important to read all safety instructions.**

These safety instructions have been prepared by LiftMaster, the manufacturer of the barrier gate. As the manufacturer of only part of the total barrier gate system, we do not know what type of controls or safety equipment that has been selected as part of your system.

An automatic vehicular gate arm is a large, heavy object that moves with the help of an electric motor. **A moving gate arm can cause serious injury or death.** Your safety and the safety of others depends on you reading, understanding, and following through on the safety instructions in this manual. It is important that both the installer and end users are aware of the hazards of your specific system.

If you have any questions or doubts about the safety of your system, or if you do not completely understand everything in this manual, contact LiftMaster.

Before Installation

- Installation of this barrier gate must be done by a qualified installer.
- Check to make sure that the available power supply to be connected to the operator is of the same voltage, phase, frequency, and wattage as indicated on the nameplate of the operator.
- Installation and wiring must be in compliance with local building and electrical codes.
- It is strongly recommended that you use safety equipment with this barrier gate operator.** There are many types of safety devices available; sensing edges, photo-electric controls, motion detectors, and vehicle detectors are some of the more common types. Audible and/or visible warning devices are recommended when automatic controls are used in the gate operating system.

If you need advice regarding the type of safety equipment that should be used on your application or wish to purchase such equipment, contact the supplier of the barrier gate, or contact LiftMaster. **Without safety equipment, the gate could cause serious injury or death.**

- Carefully plan the location of barrier gate control equipment. Do not locate controls in places where children will be able to reach or play with them. Be sure the person operating the controls can see the full area of movement of the gate arm from the point of operation.

During Installation

- Do not place hands or fingers in or near the barrier gate unless power is off. **Moving chains, pulleys, or belts can catch clothing or fingers and cause severe injury.**
- Always disconnect power and lock out whenever installing or servicing the barrier gate.
- If the barrier gate utilizes any automatic means of operation (such as automatic timed closings), **post warning signs** that are clearly visible to persons in the area warning of the particular hazards of the system.

After Installation

- Be sure that the operator, controls, and safety devices have been tested and are functioning properly.
- Review the operation of the gate and safety equipment with the owner or end user. Be sure that the end user is aware of all safety instructions and hazards of the operating system.
- Inform the owner or end user that the barrier gate and all control and safety equipment should be maintained regularly. The entire gate system should be checked at least once monthly to ensure that it is functioning properly.

With a safety edge installed, the gate **must** reverse on contact with a rigid object. If non-contact sensors are connected to the Hold Open input and an object activates them, the operator will stop a closing gate. After adjusting the force or the limit of travel, retest the gate operator. Failure to adjust and retest the gate operator properly can increase the risk of injury or death.

- Leave all installation manuals, instructions, and safety information, including this manual, with the owner or end user.
- The entrance is for vehicles only. Pedestrians must use separate entrance.
- Keep gates properly maintained.** Read the owner's manual. Have a qualified service person make repairs to gate hardware.

Preparing the Installation

Unpack Carton

- 1 Unpack the carton, checking for possible damage during shipping. The arm (when supplied) is packed separately. Damage claims must be filed with the freight carrier.
- 2 Check that the nameplate data (inside service cover) accurately matches the operator that was ordered.
- 3 Verify that the following parts are included with the standard unit.

MODEL BG770 PACKING LIST

PART NUMBER	DESCRIPTION	QUANTITY
02-102	OPEN/CLOSE PUSH BUTTON	1
07-8007	GATE ARM HUB	1
01-G0674	MANUAL	1
10-8007M	GATE BRACKET	1
80-G0187	1/2 x 1/2 x 1-3/8L KEY	1
82-NH38-06	3/8-16 x 3/8 CONE POINT SET SCREW	2
82-HN50-25	1/2-13 x 2-1/4 HEX BOLT	4
82-RH-50	1/2-13 HEX NUT	4
85-LS-50	1/2 SPLIT LOCK WASHER	4
01-G0674	BG770 & BG790 MANUALS	1

Table 1

MODEL BG790 PACKING LIST

PART NUMBER	DESCRIPTION	QUANTITY
02-102	OPEN/CLOSE PUSH BUTTON	1
07-8007	ARM HUB	2
10-8055	COUNTER WEIGHT CLAMP	2
80-G0135	3/8-16 x 18 THREADED ROD	2
80-G0187	1/2 x 1/2 x 1-3/8 KEY	2
82-HN50-25	1/2-13 x 2-1/4 HEX HEAD BOLT	12
82-HN50-28	1/2-13 x 3 HEX HEAD BOLT	2
82-NH38-06	3/8-16 x 3/8 CONE POINT SET SCREW	4
84-RH-50	1/2-13 HEX NUT	14
84-WH-38	3/8-16 SERRATED FLANGE NUT	8
85-FW-38	3/8 FLATWASHER	8
85-FW-50	1/2 FLATWASHER	8
85-LS-50	1/2 SPLIT LOCK WASHER	16
01-G0674	BG770 & BG790 MANUALS	1

Table 2

Preparing the Site

- 1 Be sure that selected gate location has required clearance for arm movement (and counterweights on model BG790). Refer to the dimensional drawings, Figure 1 and Figure 2 on page 4.
- 2 Run electrical power to the site according to local electrical codes. See Table 3 below for correct wire size and length of run (see also Figure 3). If the wire gauge is too high (wire too small) or the run is too long, the gate may not run properly or may not run at all. **Damage to components may result.**



IMPORTANT NOTE: Be sure that the available power is the proper voltage, phase, frequency, and amperage to supply the gate. Refer to gate nameplate located inside the service cover.

- 3 Select locations for control equipment and run any control wiring that may be needed (such as loop wires, card readers, ticket spitters, pushbuttons, etc.).

WIRE SIZING CHART

	SINGLE PHASE	THREE PHASE			
	115VAC	230VAC	230 VAC	460 VAC	575VAC
AWG	Maximum Length of Wire Run in Feet				
6	700	3,100	4,750	14,225	35,550
8	450	1,925	3,000	8,975	22,425
10	275	1,225	1,900	5,650	14,075
12	175	775	1,175	3,525	8,825

Table 3

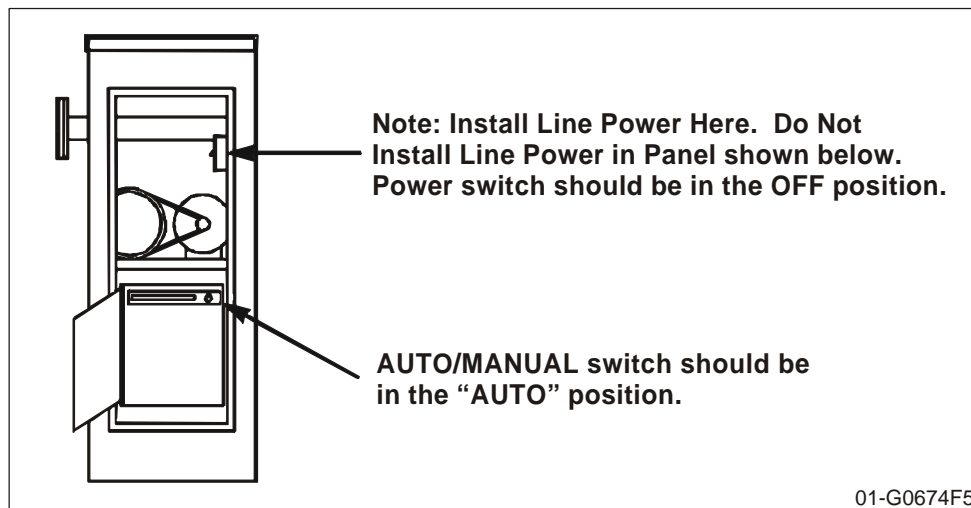

Figure 3

Preparing the Operator



CAUTION

Never open electrical cabinet cover unless power is off. Electrical shock and serious injury could result.

- 1 Remove the wood base from the unit and discard.
- 2 Locate the keys for the access panel (taped to the arm mounting flange) and remove.
- 3 Open the side access panel and check the position of the power ON/OFF switch.
- 4 Open the cover of the electrical cabinet and be sure that the AUTO/MANUAL switch is in the "AUTO" position.
- 5 **OPTIONAL CONTROL EQUIPMENT:** If loop detectors, radio controls, or other control equipment will be added at the site, do so now. Refer to the instructions in this manual for installation of factory supplied optional open and/or hold open loop detectors, and for connection of factory supplied optional radio controls (see **Optional Accessories** on page 19).

Installation

Step 1: Mounting

- 1 Layout the concrete pad as detailed in Figure 4. Be sure to locate electrical conduit inside the hatched 14" x 13" area.
- 2 Excavate required area for pad and conduit. Pad depth should be below the frost line, or as required by local codes.
- 3 Locate four 1/2" X 6" long L-bolts (not supplied) as shown in Figure 4. The L-bolts should protrude 1 1/2" inches above the pad.
- 4 Pour concrete, insuring that the pad is level and above the ground line.
- 5 Allow the concrete to set at least two days before installing gate.

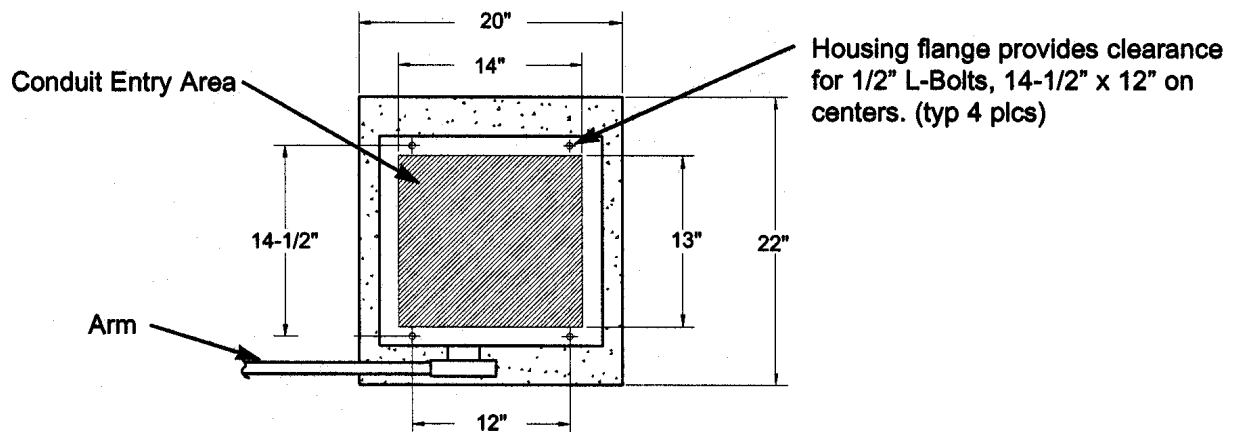

Figure 4: Concrete Pad Layout

Step 2: Arm Fabrication

MODEL BG770 (SINGLE ARM)

If you are making the arm yourself, refer to Figure 5 and its suggestions for the single arm design.

- 1 Drill four 1/2" diameter holes using the arm clamp as a template. Tapering the wood as shown helps reduce the weight and allows you to reduce any warping common with long lengths of lumber.
- 2 Finish arm with exterior grade paint and stripe with paint or adhesive backed tape as required.

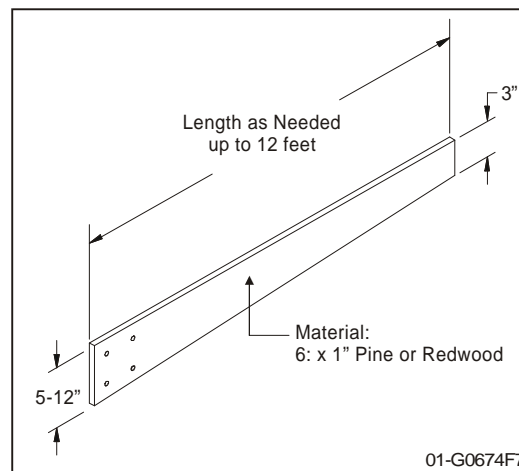

Figure 5

MODEL BG790 (WISHBONE ARM)

A twenty-four foot wishbone arm is supplied as standard with every BG790 gate. If a shorter arm is desired the extension may be shortened. See Figure 6. The maximum arm extension is 8 feet for a total arm length of 24 feet.

- 1 Cut to desired length.
- 2 Finish with an exterior grade paint and stripe with paint or adhesive backed tape as required.

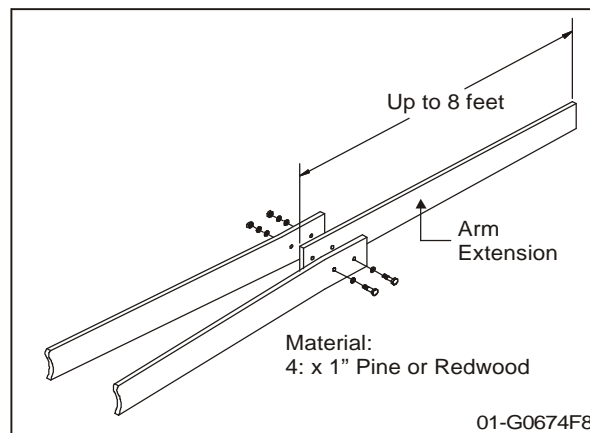

Figure 6

Step 3: Wiring Connections

Locate the electrical enclosure inside the cabinet. The enclosure (shipped loose) may be removed from the cabinet to help in the connections described below. When all connections are complete, hang the enclosure as described in step 7.



WARNING

Consult local electrical codes for permanent wiring requirements at your installation site.

- 1 Open the cover of the electrical enclosure. Refer to the wiring diagram supplied inside for all electrical connections.
- 2 Be sure that power supply is of the correct voltage, phase, frequency, and amperage to supply operator. Refer to the operator nameplate on electrical cabinet cover.



CAUTION

Do not turn on electrical power until you have carefully read the **Limit Switch Adjustments** section on page 18. Also, this unit must be properly grounded. A ground screw is supplied in the switch box for connection of the power supply ground wire. **Failure to properly ground this unit could result in electrical shock and serious injury.**

- 3 Connect power supply wires to the ON/OFF power switch as shown on the operator wiring diagram and Figure 3 (see page 9). **Do Not** connect power at control panel (L1, L2, L3). Route wires away from belt and limit switches.
- 4 A two button control station (OPEN/CLOSE) is provided as standard equipment with every BG770 and BG790 barrier gate. If you are not using automatic controls to control the gate, the two button station may be connected as shown on the wiring diagram supplied with the gate to control the gate manually. However, the AUTO/MANUAL switch should be kept in the "AUTO" position.



IMPORTANT NOTE: Use 16 gauge wire or larger for all control wiring connections. **If the control wire is too small, damage to the operator components may result.**

- 5 The control station must be mounted in a location adjacent to and within clear sight of the gate. If you will mount the control station outdoors, replace the standard station supplied with the operator with a weatherproof station.
- 6 The BG770 and BG790 barrier gates will interface with almost all types of commonly used control stations, radio controls, and access control equipment. Refer to the wiring diagram for connection of these devices.

If you are using a loop detector to open and/or hold open and close, mounting space and plug-in harnesses are provided in the electrical cabinet for installation of optional factory supplied detectors. You may also use other detectors. Refer to the **Optional Accessories** section on page 19.

- 7 When all wiring connections are complete, mount the electrical enclosure to the shelf housing shelf. **MODEL BG770:** Hang electrical enclosure on the two screws provided on the front of the shelf in the housing. **MODEL BG790:** Hang electrical enclosure on the two screws provided on the cross angle under shelf in the housing.

Step 4: Arm Attachment

For easier access during installation, the top cover of the unit may be opened by removing the two wing nuts from underneath, inside the cabinet.



WARNING

When following the procedure below, the motor belt will turn and the drive shaft will move during some of the steps. **Keep hands and tools out of the gate cabinet and away from the belt and drive shaft or serious injury may result.** Be sure to disconnect power while installing the arm attachment.

MODEL BG770: STANDARD ARM

Attach arm to the arm hub flange as shown in Figure 7.

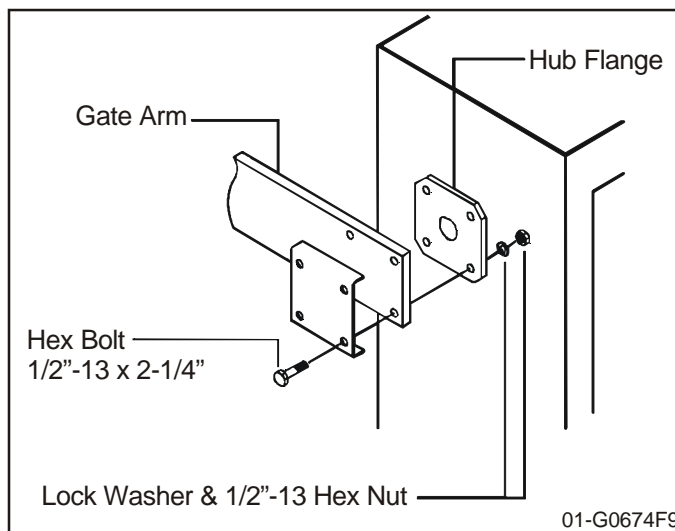

Figure 7

MODEL BG770: OPTIONAL ARM

Attach arm to the arm hub flange as shown in Figure 8.

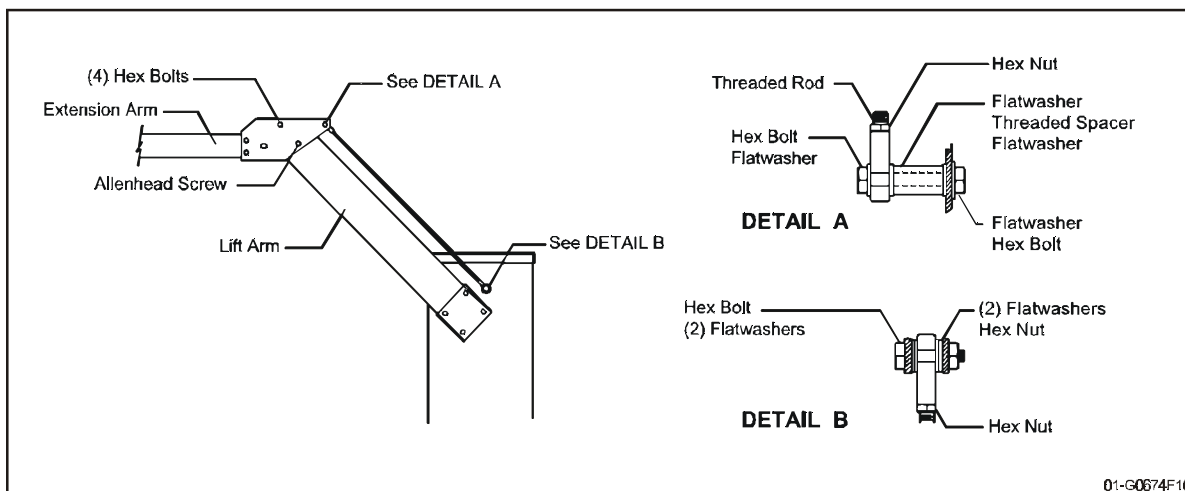

Figure 8

BG790: WISHBONE COUNTERWEIGHTED ARM

Attach left and right arms to the arm hub flanges as shown and described below.

- 1 Bolt counterweights to ends of arms clamps as shown. Use Caution lifting 57lb. weights.
- 2 Bend and fasten the two arms together as shown in Figure 10.

If an extension arm is required, sandwich the extension arm between the two halves of the wishbone arm before bolting together. See **Arm Fabrication** starting on page 12 for extension arm preparation.

- 3 Assemble the two 3/8" threaded rods to the arms for center support as shown in Figure 10.
- 4 Turn on power and test the gate.

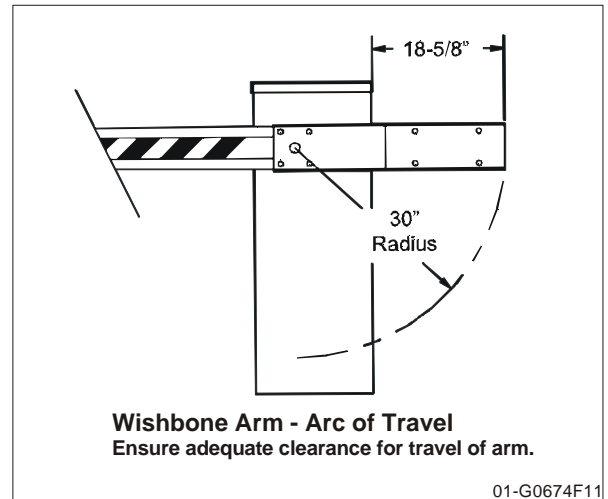

Figure 9



WARNING

Be prepared for gate to start when you turn the power on.

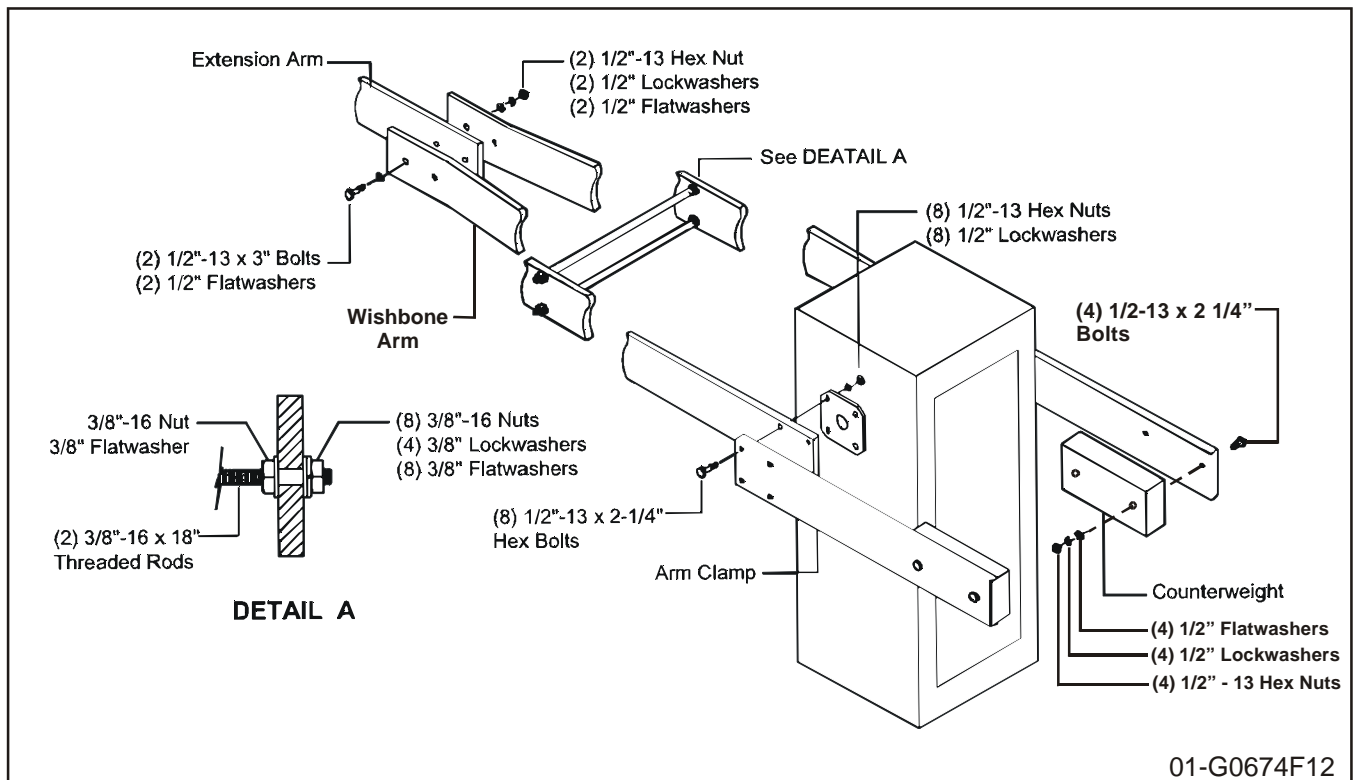

Figure 10

Step 5: Arm and Turnbuckle Shaft Adjustments



CAUTION

Turn off power before making any adjustments.

MODEL BG770 ADJUSTMENTS

- 1 If necessary, rotate the pulley on the motor by hand until the crank arm on the gear reducer is perfectly aligned with the turnbuckle shaft (see Figure 11). This is the lowest point of the arm travel and should be preset in this position at the factory.
- 2 If the arm is not level, loosen the jam nuts at both ends of the turnbuckle shaft. Insert a screwdriver or other similar tool into the hole in the shaft. Rotate the shaft either CW or CCW as necessary until the gate arm is in the desired horizontal position. Retighten jam nuts.

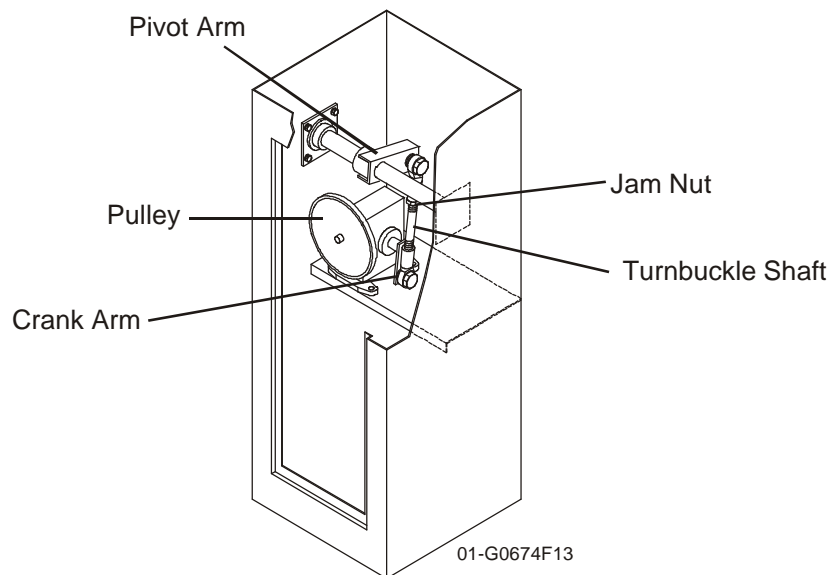

Figure 11: Model BG770

BG770 TURNBUCKLE SHAFT ALIGNMENT

If necessary align turnbuckle shaft with center of crank arm for **lowest point** of travel of pivot arm (see Figure 12).

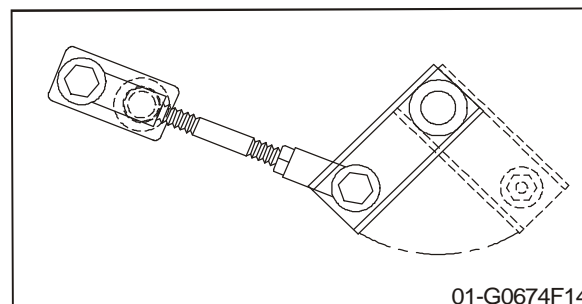



Figure 12

MODEL BG790 ADJUSTMENTS

- 1 If necessary, rotate the pulley on the motor by hand until the upper and lower cranks are in a vertical position (see Figure 13). This is the lowest point of travel and should be preset in this position at the factory.
- 2 If the arm is not level, loosen the jam nuts on both the top and bottom end of the turnbuckle shaft.
- 3 Rotate the shaft either CW or CCW as necessary until the gate arm is in the desired horizontal position.

 **NOTE:** While the arm is raising, the upper and lower cranks should travel toward the side access cover.

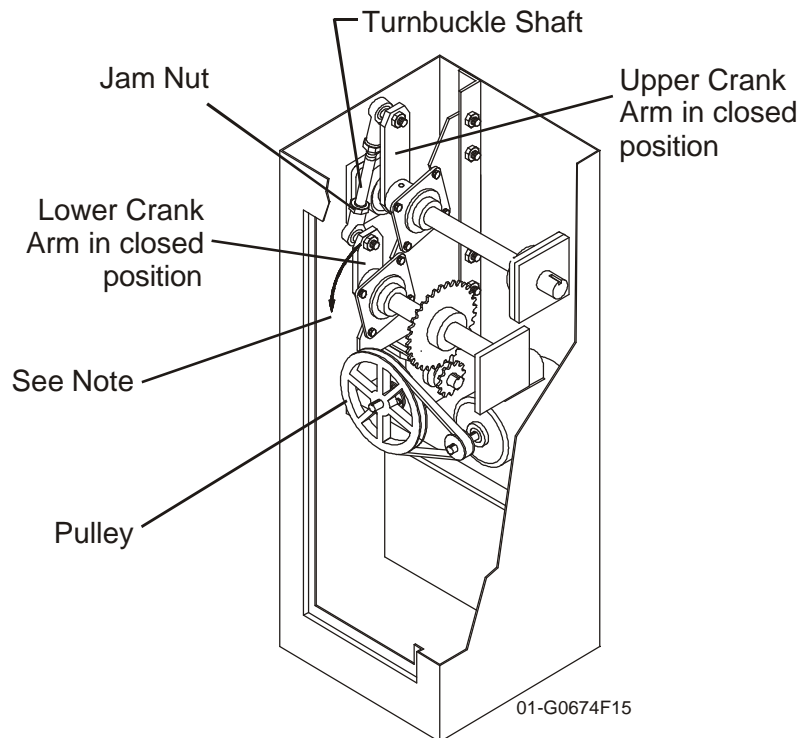

Figure 13: Model BG790

Step 6: Limit Switch Adjustments

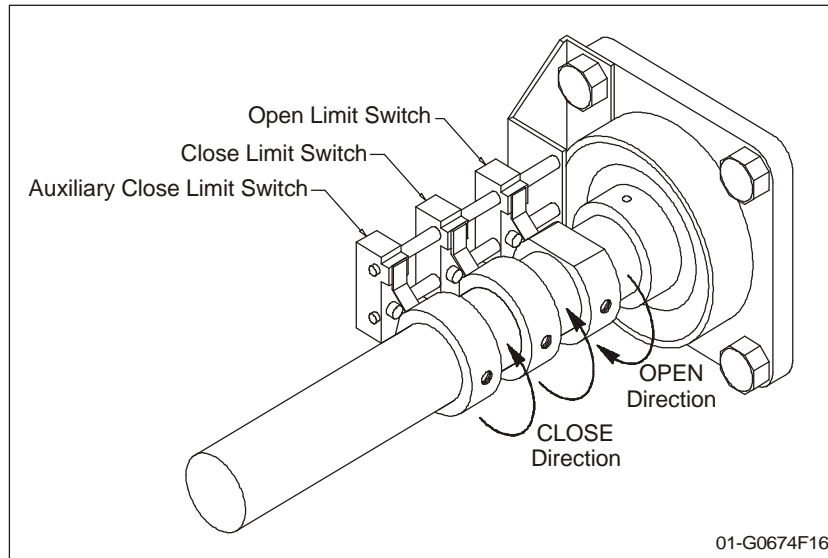

Figure 14: Limit Switch Layout

CLOSE LIMIT SWITCH

The CLOSE limit switch is preset at the factory. If you rotated the pulley in section **Arm and Turnbuckle Shaft Adjustments** (page 16), you will need to reset the cam on the CLOSE limit switch.

- 1 Back out the set screw on the cam. Then rotate the cam in the close direction so that the switch just clicks when the gate arm is in its lowest position (see Figure 14).
- 2 When the cam is in the desired position, retighten the set screw. This adjustment may have to be fine tuned after turning on power and running the unit for the first time.

AUXILIARY CLOSE LIMIT SWITCH

The AUXILIARY CLOSE limit switch is preset at the factory. If you made an adjustment to the CLOSE cam, you will need to adjust the cam on the AUXILIARY CLOSE limit switch also.

- 1 Position the AUXILIARY CLOSE cam slightly ahead of the CLOSE cam. When the gate arm is on its down travel, the AUXILIARY CLOSE switch will click just before the CLOSE switch.
- 2 When the cam is in the desired position, retighten the set screw.

OPEN LIMIT SWITCH

The OPEN limit switch is preset the factory. This setting may have to be fine tuned after running the unit for the first time.

- 1 Loosen the OPEN cam and rotate in the open direction until the switch just clicks. See Figure 14.
- 2 Retighten the cam.

Optional Accessories



CAUTION

Turn off power before working inside gate enclosure.

Vehicle Detectors

Almost all types of vehicle detectors may be used in conjunction with both model BG770 and BG790. More than one detector may be connected to the gate, and may be mounted inside of the cabinet. Connect the detector(s) according to the instructions on the wiring diagrams supplied with the gate and with the detector itself.

FACTORY SUPPLIED PLUG-IN DETECTORS

LiftMaster P/N 71-416-7NH = 24V

Please note: Previous models used 115V detectors (P/N 71-416-3NH).

OPEN LOOP DETECTOR

- 1 Snap the detector onto one set of the four board mount standoffs located on the inside of the electrical cabinet. Plug the harness into the connector marked "OPEN".
- 2 Connect the two loop wires to terminals P1 and P2 as shown on the wiring diagram.

HOLD OPEN LOOP DETECTOR

- 1 Snap the detector onto one set of the four board mount standoffs located on the inside of the electrical cabinet. Plug the harness into the connector marked "HOLD OPEN".
- 2 Connect the loop wires to terminals P3 and P4 as shown on the wiring diagram.

Radio Controls

All types of standard radio controls may be used in conjunction with model BG770 and BG790. If the receiver is mounted inside of the gate enclosure, a commercial coaxial antenna should be used and extended through the side of the cabinet.

POWER CONNECTION

All radio receivers require a power supply. If the receiver requires 24 volts AC you may power the unit from the gate control circuit. To do this, connect the radio receiver power wires to Terminals #3 and #6 on the control terminal strip. If the receiver requires 115 volts AC or other power, you will need a separate power source.

A standard residential door radio receiver has a three wire connection marked 1, 2, 3. If you have this type, you may connect to operator terminals R3, R1, and R6. The transmitter button will open the gate if it is fully closed.

CONTROL

If you have a standard residential 3 wire receiver and made the power connection described on page 19, you are finished with the radio connections. If you want to use a radio control (such as a single button), you must order an optional kit (P/N 90-PGR).

Card Readers, Keypads, or other

Almost all types of access control devices may be connected to models BG770 and BG790. More than one device may be connected in parallel. All devices connected according to the instructions below will open the gate and reverse the gate if it is closing.

MOUNTING LOCATION

Mount or install the access control device within sight of the gate and according to the instructions supplied with the device. Some devices require their own power supply. **Do not use the 24 volt power in the gate to supply other devices.** Use either direct line voltage (115V or 230V) or other external power source as required by the particular device.



NOTE: Most access control devices have an isolated, normally open output contact to connect to the gate. If yours does not, or if you are unsure of or unfamiliar with these terms, consult the supplier of the device or a qualified gate installer.

CONTROL CONNECTION

TURN OFF POWER and connect the two output terminals (or wires) of the access control device to the terminals #1 and #3 on the control wiring terminal strip. Use a wiring method that will provide permanent, durable, and weatherproof connection between the gate and the access device.

Operating Instructions

Electrical Operation

The BG770 and BG790 barrier gate operators are designed to provide years of trouble-free operation. The gate may be operated by means of the two button control station, or by other means if provided.

ON/OFF POWER SWITCH

The gate is provided with an ON/OFF power switch. To shut power off, remove the access cover and move the toggle switch on the right side of the main electrical cabinet to the "OFF" position.

OVERLOAD PROTECTION

The motor is protected by either a manual reset (Single Phase unit) or automatic reset (3 phase unit) thermal overload protector. The overload protector will trip when the motor temperature is too hot.

DO NOT ATTEMPT TO BYPASS THIS UNIT

If the overload trips, the gate could start by itself when the overload is reset (either manual or automatic). **Exercise caution when resetting the overload.** On one phase units, the reset button is located on the cover of the electrical cabinet.

If after resetting, the overload continues to trip, consult a qualified service company.

Manual Operation



CAUTION

Keep hands clear of moving parts. The motor will start when AUTO/MANUAL Switch is flipped to the "MANUAL" position.

ACCESS CONTROL "EMERGENCY" BYPASS

To open the gate in an emergency, remove the keyed access cover and open the electrical cabinet. Flip the AUTO/MANUAL switch to the "MANUAL" position.

The gate arm will remain in the up position, and no other control device will have any effect until the switch is set back to the "AUTO" position.

Troubleshooting

When troubleshooting, one of the first things to do is try to isolate the problem area. The four (4) main areas to check out are:

- Power
- Accessories
- Operator's Primary Voltage
- Operator's Low Voltage



1. Power

Always use extreme caution! Some possible symptoms of power problems include:

- The obvious one is – the operator will not run.
- The operator runs slow.
- Circuit breakers or fuses keep tripping.
- Motor overload keeps tripping.
- Operator starts but then stops.

1A.

Using a V.O.M., take a voltage reading at the control transformer's primary terminals. You should get a reading as follows:

Nominal Volt.	Min.	Max.
120v.	108	132
230v.	207	253
460v.	414	506

Table 4

If you get a reading that does not fall into the minimum/maximum area, then check out your main power supply. Also, make sure that the operator was ordered with the proper voltage and phase. Another item to check is the wire run from the power supply to the operator. Double check the gauge of the wire versus the distance.

1B.

If the voltage reading is O.K. from 1A, then take the same voltage reading with the operator running. If voltage drops below the minimum with this reading, then there could be an excessive current draw somewhere, or a wire AWG is too small.

1C.

In some cases, power drops can occur at only specific times during the day or night. This can be caused by increased power demands in a general area at a specific time—particularly areas undergoing rapid growth.

2. Accessories

Add-on accessories can create many of the problems that are credited to the operator. Many applications have more than one accessory item attached to the operator and some of these items even draw their power from the operator.

Some of the symptoms that can show up because of accessories:

- The operator won't close.
- The operator will not run.
- The operator won't open.
- The operator begins to run, then stops or reverses.

2A.

Whenever the problem is thought to be an accessory and there are more than one connected to the operator, always disconnect one accessory at a time and then test the system. This will hopefully isolate which item is causing the problem.

2B.

If an accessory item is being used as an access control device (used to open or close), falls in the closed position or sends out a continuous signal. The operator will hold the gate in one position until the signal from the accessory is removed.

2C.

In some applications, the gate may begin to move then either stop or stop and reverse within a couple of seconds. This can be caused by an external obstruction device that has failed.

2D.

If there are many accessories attached to and powered by the operator, there may be too much current draw for the operator's control transformer. This operator can only supply approximately 2 amps @ 24 vac. Double check all accessories for their current requirements.



3. Primary Voltage Circuit

Use extreme caution when troubleshooting the primary voltage circuit! There are five (5) items in this circuit that could be causing trouble, and they are:

- Motor
- Contactor (see Figure 15)
- Transformer
- Power Disconnect Switch

3A.

The first thing to check is the incoming power. Is it there at the incoming side of the power disconnect switch?

3B.

If there is power, then check for it at the transformer primary terminals. If there is voltage at the switch and none at the transformer, then you probably have a bad power disconnect and it should be replaced. Check secondary output of transformer for 24VAC output.

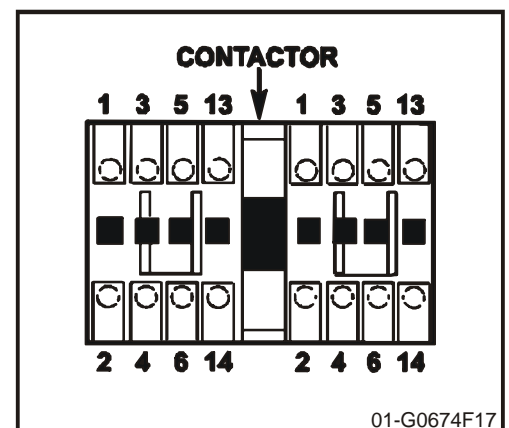

Figure 15

3C.

If 3a and 3b check out O.K., then manually disconnect the operator from the gate. **Very carefully**, using a screwdriver with an insulated handle, press down on the open side of the contactor. Then do the same to the close side of the contactor. Did the operator run in both directions? If it did, the problem may be in the low voltage control circuit. If it did not, then the problem is either in the contactor or the motor.

3D.

If the contactor is suspected to be causing the problem, first carefully check all wiring connections at the contacts (see Figure 15). **Disconnect Power!** Using a V.O.M., take continuity readings across the contacts of the contactor. Remove wires from one side of the contactor. Place one probe on 1 and the other on 2. You should get NO continuity; now press down on the contactor; you should get a continuity reading. Repeat this on all of the contactor's contact points.

3E.

If the problem is thought to be the motor, it is recommended that it be replaced. It is possible that the thermal overload inside the motor has overheated. Wait approximately 15 minutes, then try running unit.



NOTE: Some motors have the overload built into the motor itself, while other units have a separate overload in the controller (Model BG770 uses a manual reset overload).

4. Low Voltage Circuit

4A.

The first thing to check is the **circuit breaker**.

4B.

The secondary voltage must be between 22 and 30 vac. This voltage can be checked at the circuit board at terminals 3 & 6.

4C.

The **contactor** coils receive 24vac. To activate the motor in either the open or close direction. There are two contactor coils (one for open and one for close).

4D.

The **limit switches** are S.P.D.T. (single pole, double throw). These limit switches tell the operator to shut off at either the full open or full close position.

General Reference Information

THE GATE

Double check the gate and its related hardware. Does the gate move freely? Are there unprotected pinch points? - If yes, then correct.

WIRING DIAGRAM

Always reference the wiring diagram that was supplied with the operator. Note that some of the accessory items may have their own wiring diagram.

If you cannot correct the problem or if you feel you will require technical assistance, contact your local distributor or dealer. If you do not have a distributor or dealer, then contact us for technical assistance. Please when calling for assistance, make sure you have the gate operator model number, voltage, phase, horsepower and a list of all accessories that are attached to the operator.

Required Maintenance-Normal Usage



ITEM	ACTION	Check at least once every (#) of months			
		1	3	6	12
External safety systems	Check for proper operation	✓			Complete Checkout
Gate caution signs	Make sure they are present	✓			
Drive chain (see notes)	Check for excessive slack and lubricate			✓	
Sprockets & pulleys	Check for set screw tightness			✓	
Gate	Inspect for wear or damage	✓			
Accessories	Check all for proper operation			✓	
Electrical	Inspect all wire connections			✓	
Frame bolts	Check for tightness			✓	
Total unit	Inspect for wear or damage				

Table 5



CAUTION

When servicing, always disconnect operator from electrical power supply.



NOTES

- Inspection and service should always be performed anytime a malfunction is observed or suspected.
- Limit switches may have to be reset after any major drive chain adjustments.
- **BG790:** If lubricating chain, use only a proper chain lub spray or a lightweight motor oil. Never use grease or silicone spray.
- When servicing, please do some “house cleaning” of the operator and the area around the operator. Pick up any debris in the area. Clean the operator if needed.
- Severe or high cycle usage will require more frequent maintenance checks.
- It is suggested that while you are at the site, take some voltage readings of the operator. Using a VOM, double check the incoming voltage to the operator to make sure it is within ten percent of the operator’s rating.
- While you are at the site, now would be a good time to let the owner or manager know about any new items available or any safety items that could and should be added to the site.

LIMITED BEARING LUBRICATION

The barrier gates require very little in the way of maintenance. Motor and shaft bearing normally should not require lubrication. The gear oil in the gear reducer is sealed in. Unless a severe problem causes a seal to break, it should never need replacement. If gear oil is required, use Mobilube C SAE140 or equivalent.

GREASE TURNBUCKLE

Periodically grease the ball ends of the turnbuckle, depending on the gate’s frequency of use.

Warranty Policy

Seller warrants that the goods are free from defect in materials and/or workmanship for a period of one year from the date of shipment from the F.O.B. point. Goods returned to Seller for warranty repair within the warranty period, which upon receipt by Seller are confirmed to be defective and covered by this limited warranty, will be repaired or replaced (at Seller's sole option) at no cost and returned pre-paid. Defective parts will be repaired or replaced with new or factory-rebuilt parts at Seller's sole option. Authorization instructions for the return of any goods must be obtained by Buyer from Seller before returning the goods. The goods must be returned with complete identification, freight prepaid, and in accordance with Seller's instructions or they will not be accepted. In no event will Seller be responsible for goods returned without proper authorization or identification

THIS LIMITED WARRANTY IS IN LIEU OF ANY OTHER WARRANTIES, EXPRESS OR IMPLIED, INCLUDING ANY IMPLIED WARRANTY OF MERCHANTABILITY OR FITNESS FOR A PARTICULAR PURPOSE, OR OTHERWISE, AND OF ANY OTHER OBLIGATIONS OR LIABILITY ON SELLER'S PART. THIS LIMITED WARRANTY DOES NOT COVER NON-DEFECT DAMAGE, DAMAGE CAUSED BY IMPROPER INSTALLATION, OPERATION OR CARE (INCLUDING, BUT NOT LIMITED TO ABUSE, MISUSE, FAILURE TO PROVIDE REASONABLE AND NECESSARY MAINTENANCE, OR ANY ALTERATIONS TO THIS PRODUCT), LABOR CHARGES FOR DISMANTLING OR REINSTALLING A REPAIRED OR REPLACED UNIT, OR REPLACEMENT BATTERIES. UNDER NO CIRCUMSTANCES SHALL SELLER BE LIABLE FOR CONSEQUENTIAL, INCIDENTAL OR SPECIAL DAMAGES ARISING IN CONNECTION WITH THE USE, OR INABILITY TO USE, THIS PRODUCT. IN NO EVENT SHALL SELLER'S LIABILITY FOR BREACH OF WARRANTY, BREACH OF CONTRACT, NEGLIGENCE OR STRICT LIABILITY EXCEED THE COST OF THE PRODUCT COVERED HEREBY. NO PERSON IS AUTHORIZED TO ASSUME FOR US ANY OTHER LIABILITY IN CONNECTION WITH THE SALE OF THIS PRODUCT. Some states do not allow the exclusion or limitation of consequential, incidental or special damages, so the above limitation or exclusion may not apply to you. This limited warranty gives you specific legal rights, and you may also have other rights which vary from state to state.

BG770 Drawing and Parts List

BG770 Exploded View

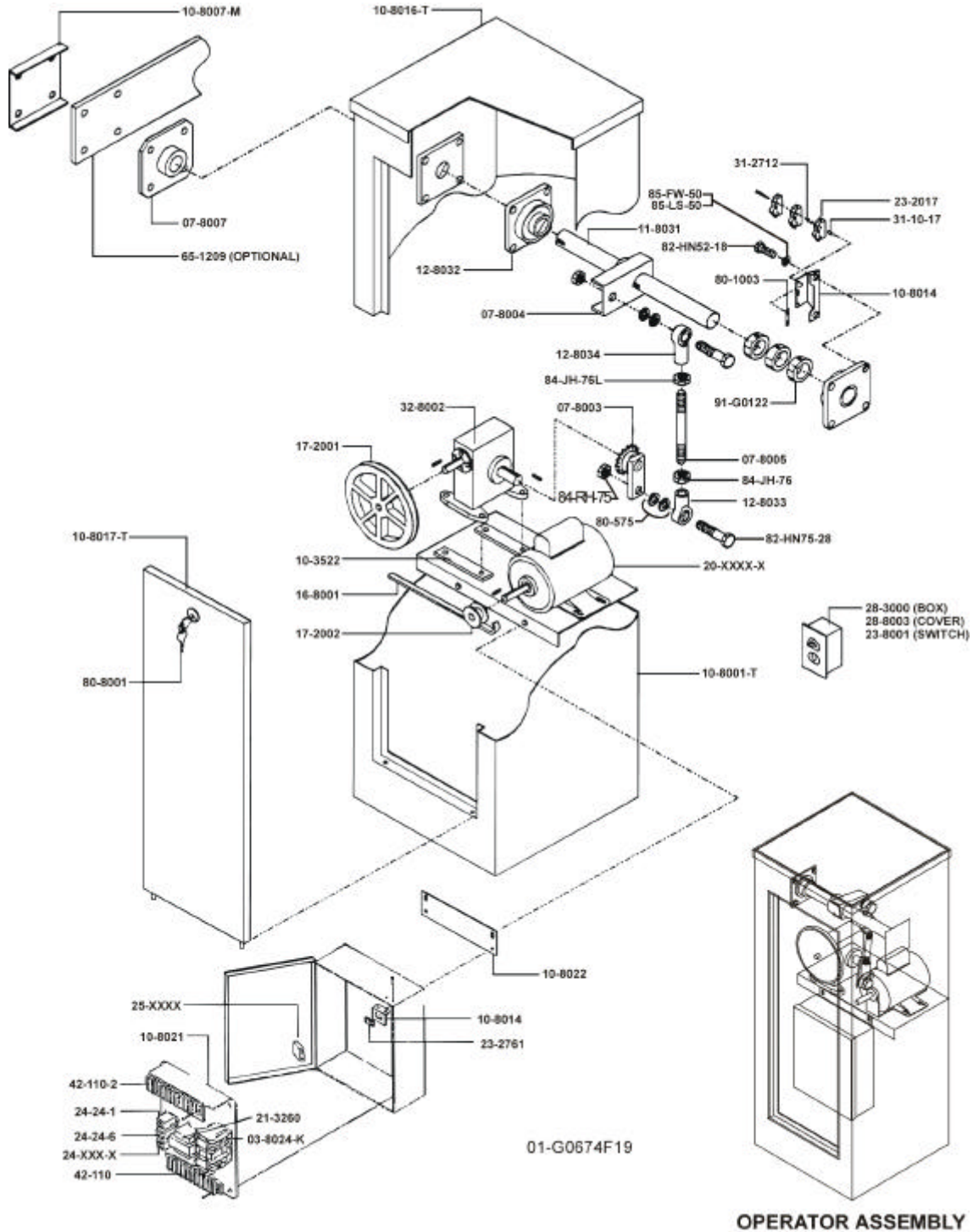

Figure 16

BG770 Parts List

STANDARD PARTS					
PART NO.	QTY.	DESCRIPTION	PART NO.	QTY.	DESCRIPTION
02-102 (N)	1	KEY SWITCH	80-207-36 (N)	1	1/4 x 1/4 x 1-1/4 KEY
03-8024-K	1	3 POLE CONTACTOR	80-5001 (N)	2	3/16 x 3/16 X 3/4 KEY
03-ABDIN-4 (N)	1	DIN RAIL	80-575	6	3/4 FLATWASHER
07-8003	1	LOWER CRANK	80-8001	1	ACCESS PANEL LOCK
07-8004	1	UPPER CRANK	80-G0186 (N)	1	1/2 x 1/2 x 2-1/4 KEY
07-8005	1	CRANK LINK	80-G0187 (N)	1	1/2 x 1/2 x 1-3/8 KEY
07-8007	1	GATE ARM HUB	81-8000 (N)	8	SHOCK MOUNT
10-3522	2	REDUCER SHIM	81-PX06-06T (N)	6	6-32 x 3/8 SELF TAPPING SCREW
10-8001-T	1	TAN BARRIER GATE ENCLOSURE	82-CB31-26 (N)	4	5/16-18 x 2-1/2 CARRIAGE BOLT
10-8007M	1	GATE BRACKET	82-HN25-08 (N)	2	1/4-20 x 1/2 HEX HEAD BOLT
10-8014	1	SWITCH BRACKET	82-HN25-18 (N)	4	1/4-20 x 1-1/4 HEX BOLT
10-8016-T	1	TAN TOP COVER	82-HN31-16 (N)	4	5/16-18 X 1 HEX HEAD BOLT
10-8017-T	1	TAN ACCESS COVER	82-HN50-25 (N)	4	1/2-13 x 2-1/4 HEX HEAD BOLT
10-8021	1	ELECTRICAL PANEL	82-HN52-18	8	1/2-20 x 1-1/4 HEX HEAD BOLT
10-8022	1	ELEC. PANEL MOUNT. BRACKET	82-HN75-28	1	3/4-10 x 3 HEX HEAD BOLT
N/A	N/A	N/A	82-NH31-06 (N)	1	5/16-18 x 3/8 SET SCREW
11-8031	1	SHAFT	82-NH38-06 (N)	4	3/8-16 x 3/8 CONE POINT SET SCREW
12-8032	2	4 BOLT FLANGE	82-PX06-28 (N)	2	6-32 X 3 PAN HEAD SLOTTED SCREW
12-8033	1	FEMALE ROD END	82-PX08-04T (N)	6	8-32 x 1/4 SELF TAPPING SCREW
12-8034	1	FEMALE ROD END	82-PX08-10T (N)	4	8-32 X 5/8 SELF TAPPING SCREW
13-8000 (N)	14	METAL GASKET	82-QN31-12 (N)	2	5/16-18 x 3/4 SQUARE HEAD BOLT
13-8001 (N)	1	RUBBER GROMMET	82-QN75-26 (N)	1	3/4-10 x 2-1/2 SQUARE HEAD BOLT
16-8001	1	V-BELT	82-RS10-20 (N)	2	10-32 x 1-1/2 SLOTTED SCREW
17-2001	1	8" PULLEY	82-HN38-24 (N)	4	3/8-16 x 2 HEX HEAD BOLT
17-2002	1	2" PULLEY	84-JH-75 (N)	1	3/4-10 JAM NUT
21-3260-1	1	TRANSFORMER	84-JH-76	1	3/4-16 JAM NUT
23-2017	3	SPDT LIMIT SWITCH	84-JH-76L	1	3/4-16 LEFT HAND JAM NUT
23-2761	1	ROCKER SWITCH	84-RH-50 (N)	4	1/2-13 HEX NUT
23-8001	1	TOGGLE OUTLET	84-RH-75	1	3/4-10 HEX NUT
24-24-1	1	24VAC DPDT RELAY	84-WH-10 (N)	2	10-32 SERRATED WASHER HEAD NUT
24-24-6	1	3 PDT 24V RELAY	84-WH-25 (N)	12	1/4-20 SERRATED FLANGE NUT
28-3000	1	SWITCH BOX	84-WH-31 (N)	8	5/16-18 SERRATED FLANGE LOCK NUT
28-8003	1	DUPLEX OUTLET COVER	84-WH-38 (N)	4	3/8-16 SERRATED FLANGE LOCK NUT
31-10-17	2	1-32 x 1/8 SPACER	84-WN-25 (N)	2	1/4-20 WING NUT
31-2712	6	NYLON SENSOR SPACER	85-FW-31 (N)	4	5/16 FLATWASHER
32-8002	1	BARRIER GATE GEAR REDUCER	85-FW-38 (N)	4	3/8 FLATWASHER
42-110-2	1	10 POS. TERMINATION BLOCK	85-FW-50	6	1/2 FLATWASHER
42-3608 (N)	1	8 POSITION TERMINAL BLOCK	85-LS-50	12	1/2 SPLIT LOCKWASHER
65-1209	1	SINGLE ARM (OPTIONAL)	85-LS-75 (N)	2	3/4 SPLIT LOCKWASHER
74-G0120 (N)	1	115V CONTROL BOX	91-G0122	4	LIMIT COLLAR
80-1003	1	6-32 TINNEMAN NUT	91-G0128 (N)	1	ELECTRICAL ENCLOSURE
80-1904N (N)	8	FAILSAFE BOARD STAND OFF			

PARTS DESIGNATED (N) ARE NOT SHOWN ON DRAWING.
 PARTS HAVING ONE OR MORE X IN THE PART NO. VARY FROM MODEL TO MODEL. SEE "VARIABLE PARTS" BELOW.

VARIABLE PARTS			
VARIABLE	P/N	DESCRIPTION	USED ON
20-XXXX	20-1050B-2	MOTOR: 1/2 HP - 115/208/230VAC - 1Ø - 60hz	BG770-50-11, BG770-50-21, BG770-50-81
	20-3050B-4E	MOTOR: 1/2 HP - 208/230/460VAC - 3Ø - 60hz	BG770-50-23, BG770-50-43, BG770-50-83
	20-3050M-5	MOTOR: 1/2 HP - 575VAC - 3Ø - 60hz	BG770-50-53
24-XXXX	24-115-1	115VAC RELAY	ALL 115VAC - 1Ø MODELS
	24-230-5	208/230VAC RELAY	ALL 208/230VAC - 1Ø MODELS
	25-2006	6A FUSE	BG770-50-21
25-XXXX	25-2010	10A FUSE	BG770-50-11
	N/A	N/A	N/A
	N/A	N/A	N/A

Table 6

BG790 Drawing and Parts List

BG790 Exploded View

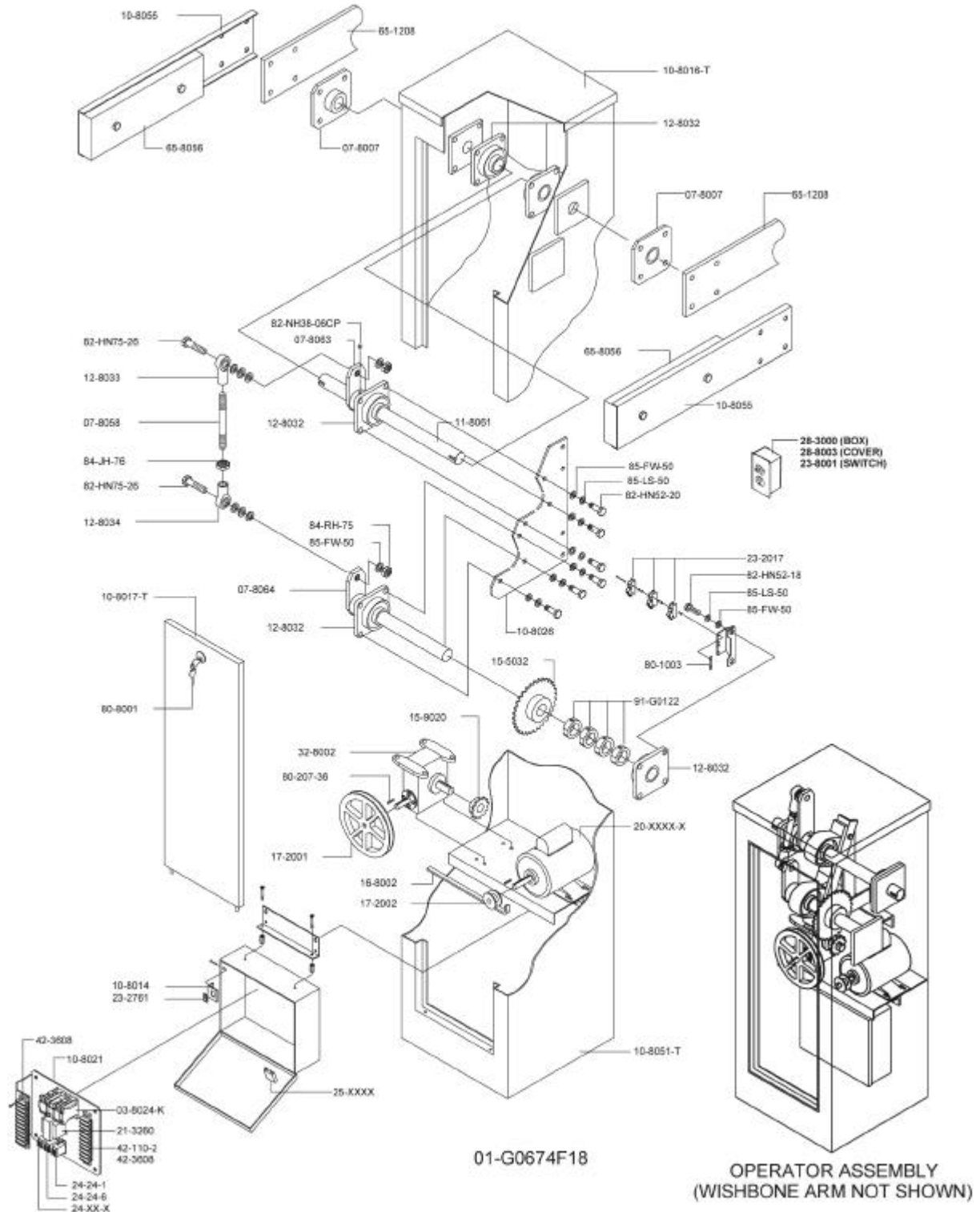

Figure 16

BG790 Parts List

STANDARD PARTS					
PART NO.	QTY.	DESCRIPTION	PART NO.	QTY.	DESCRIPTION
02-102 (N)	1	OPEN/CLOSE KEY SWITCH	80-1904N (N)	8	FAILSAFE BOARD STAND OFF
03-8024-K	1	3 POLE CONTACTOR	80-207-36	1	1/4 X 1/4 x 1-1/4 DISCONNECT KEY
03-ABDIN-4 (N)	1	DIN RAIL	80-5001 (N)	1	3/16 x 3/16 x 1-3/4 KEY
07-8007	2	ARM HUB	80-575 (N)	4	3/4 FLATWASHER
07-8058	1	CRANK LINK	80-8001	1	ACCESS PANEL LOCK
07-8063	1	UPPER CRANK	80-G0135 (N)	2	3/8-16 x 18 THREADED ROD
07-8064	1	LOWER CRANK	80-G0185 (N)	1	1/2 x 1/2 X 2-1/2 KEY
10-8014	1	SWITCH BRACKET	80-G0187 (N)	3	1/2 x 1/2 x 1-3/8 KEY
10-8016-T	1	TAN TOP COVER	80-G0188 (N)	1	1/2 x 1/2 x 2 KEY
10-8017-T	1	TAN ACCESS COVER	80-G0211 (N)	4	5/16 X 1-1/4 STUD
10-8021	1	ELECTRICAL PANEL	81-8000 (N)	8	SHOCK MOUNT
10-8026	1	BEARING PLATE	82-CB31-26 (N)	4	5/16-18 x 2-1/2 CARRIAGE BOLT
10-8027 (N)	1	ELECTRICAL PANEL HANGER KIT	82-HN25-08 (N)	2	1/4-20 x 1/2 SCREW
10-8051-T	1	TAN HOUSING	82-HN25-18 (N)	4	1/4-20 x 1-1/4 SCREW
10-8055	2	COUNTERWEIGHT CLAMP	82-HN31-16 (N)	4	5/16-18 X 1 HEX HEAD BOLT
N/A	N/A	N/A	82-HN50-20 (N)	4	1/2-13 x 1-1/2 HEX HEAD BOLT
11-8061	1	MAIN SHAFT	82-HN50-25 (N)	12	1/2-13 X 2-1/4 HEX HEAD BOLT
11-8062 (N)	1	INTERMEDIATE SHAFT	82-HN50-28 (N)	2	1/2-13 X 3 HEX HEAD BOLT
12-8032	5	4 BOLT FLANGED BEARING	82-HN52-18	18	1/2-20 X 1-1/4 HEX HEAD BOLT
12-8033	1	FEMALE ROD END	82-HN52-20	6	1/2-20 X 1-1/2 HEX HEAD BOLT
12-8034	1	FEMALE ROD END	82-HN75-26	2	3/4-10 X 2-1/2 HEX HEAD BOLT
13-8000 (N)	14	METAL GASKET	82-NH31-06CP (N)	1	5/16-18 X 3/8 SET SCREW
13-8001 (N)	2	RUBBER GROMMET	82-NH38-06CP	8	3/8-16 X 3/8 CONE POINT SET SCREW
15-5032	1	50B32 SPROCKET	82-PX06-06T (N)	6	6-32 x 3/8 SELF TAPPING SCREW
15-9020	1	50B12 SPROCKET	82-PX06-28 (N)	2	6-32 X 3 SCREW
16-8002	1	COGGED BELT	82-PX08-04T (N)	6	8-32 x 1/4 SELF TAPPING SCREW
17-2001	1	8" PULLEY	82-PX08-10T (N)	4	8-32 x 5/8 SELF TAPPING SCREW
17-2002	1	2" PULLEY	82-RS10-20 (N)	2	10-32 x 1-1/2 SCREW
19-5051 (N)	1	#50 CHAIN	82-SH10-18 (N)	2	10-32 X 1-1/4 SCREW
19-9024 (N)	1	#50 CHAIN MASTER LINK	84-JH-76	1	3/4-16 JAM NUT
19-9025 (N)	1	#50 CHAIN HALF LINK	84-JH-76L (N)	1	3/4-16 LEFT HAND JAM NUT
21-3260-1	1	TRANSFORMER	84-RH-50 (N)	18	1/2-13 HEX NUT
23-2017	3	SPDT LIMIT SWITCH	84-RH-75	2	3/4-10 HEX NUT
23-2761	1	ROCKER SWITCH	84-WH-10 (N)	10	10-32 SERRATED WASHER NUT
23-8001	1	TOGGLE/OUTLET COMBINATION	84-WH-25 (N)	14	1/4-20 SERRATED FLANGE NUT
24-24-1	1	24VAC DPDT RELAY	84-WH-31 (N)	12	5/16-18 SERR. FLANGE LOCK NUT
24-24-6	1	3PDT 24V RELAY	84-WH-38 (N)	8	3/8-16 SERRATED FLANGE NUT
28-3000	1	SWITCH BOX	84-WN-25 (N)	2	1/4-20 WING NUT
28-8003	1	DUPLEX OUTLET COVER	85-FW-31 (N)	8	5/16 FLATWASHER
31-10-17 (N)	2	1-32 x 1-1/8 SPACER	85-FW-38 (N)	12	3/8 FLATWASHER
31-2712 (N)	6	NYLON SENSOR SPACER	85-FW-50	24	1/2 FLATWASHER
32-8002	1	GEAR REDUCER	85-LS-31 (N)	4	5/16 SPLIT LOCK WASHER
42-110-2	1	10 POSITION TERMINAL BLOCK	85-LS-50	38	1/2 SPLIT LOCK WASHER
42-3608	1	8 POSITION TERMINAL BLOCK	85-LS-75 (N)	2	3/4 SPLIT LOCK WASHER
65-1208	1	WISHBONE ARM	91-G0122	4	LIMIT COLLAR
65-8056	1	COUNTERWEIGHT KIT	91-G0128 (N)	1	ELECTRICAL ENCLOSURE
74-G0133 (N)	1	CONTROL BOX	94-G0233 (N)	1	POWER CABLE
80-1003	1	6-32 TINNEMAN NUT	94-G0234 (N)	1	MOTOR CABLE

PARTS DESIGNATED (N) ARE NOT SHOWN ON DRAWING.
PARTS HAVING ONE OR MORE X IN THE PART NO. VARY FROM MODEL TO MODEL. SEE "VARIABLE PARTS" BELOW.

VARIABLE PARTS			
VARIABLE	P/N	DESCRIPTION	USED ON
20-XXXX	20-1050B-2	MOTOR: BM 115/230V 1/2HP	BG790-50-11, BG790-50-21, BG790-50-81
	20-3050B-4E	MOTOR: 1/2 HP - 208/230/460VAC - 3Ø - 60hz	BG790-50-23, BG790-50-43, BG790-50-83
	20-3050M-5	MOTOR: 1/2 HP - 575VAC - 3Ø - 60hz	BG790-50-53
24-XXXX	24-115-1	115VAC RELAY	ALL 115VAC - 1Ø MODELS
	24-230-5	208/230VAC RELAY	ALL 208/230VAC - 1Ø MODELS
25-XXXX	25-2006	6A FUSE	BG790-50-21
	25-2010	10A FUSE	BG790-50-11

Table 7



COPYRIGHT© 2001
ALL RIGHTS RESERVED

This document is protected by copyright and may not be copied or adapted without the prior written consent of LiftMaster. This documentation contains information proprietary to LiftMaster and such information may not be distributed without the prior written consent of LiftMaster. The software and firmware included in the LiftMaster product as they relate to this documentation are also protected by copyright and contain information proprietary to LiftMaster.

FOR TECHNICAL SUPPORT

Call our toll free numbers:

(800) 323-2276

(800) 998-9197

Installation and service information is available six days a week.

TO ORDER REPAIR PARTS

Call our toll free numbers:

(800) 528-2806

(800) 998-9197

Prepare to provide the following information when ordering repair parts:

- Part Number**
- Part Name**
- Model Number**